

iX™ Pay Secure Payment

INSTALLATION

iX Pay (U.S.) Retrofit
Kit for Tokheim Premier C
Wide Body Dispensers

ONLY SPM CERTIFIED TECHNICIANS
SHOULD INSTALL THIS KIT



READ THIS MANUAL BEFORE YOU BEGIN

Dispensers have both electricity and a hazardous, flammable and potentially explosive liquid. Failure to follow the below precautions and the Warning and Caution instructions in this manual may result in serious injury. Follow all rules, codes and laws that apply to your area and installation.

SAFETY PRECAUTIONS - INSTALLATION AND MAINTENANCE

Always make sure ALL power to the dispenser is turned OFF before you open the dispenser cabinet for maintenance. Physically lock, restrict access to, or tag the circuit breakers you turn off when servicing the dispenser. Be sure to trip (close) the emergency valve(s) under the dispenser BEFORE beginning maintenance.

Make sure that you know how to turn OFF power to the dispenser and submersible pumps in an emergency. Have all leaks or defects repaired immediately.

EQUIPMENT PRECAUTIONS

Be sure to bleed all air from product lines of remote dispensers and prime suction pumps before dispensing product, otherwise, damage to the equipment may occur. Always use the approved method for lifting the dispenser. Never lift by the nozzle boot, sheet metal, valance, etc., otherwise equipment damage or personal injury may occur.

HOW TO CONTACT WAYNE

Problems with the installation of this kit should be referred to Wayne Technical Support (1-800-926-3737).

INDICATORS AND NOTATIONS

**DANGER**

Danger indicates a hazard or unsafe practice which, if not avoided, will result in severe injury or possibly death.

**WARNING**

Warning indicates a hazard or unsafe practice which, if not avoided, may result in severe injury or possibly death.

**CAUTION**

Caution indicates a hazard or unsafe practice which, if not avoided, may result in minor injury.

NOTE:

Important information to consider, otherwise, improper installation and/or damage to components may occur.

Secure Payment (SPM) (U.S.) Kits for
Tokheim Premier C Wide Body Dispensers

Installation

Premier iX PAY Retrofit Kit
MODEL DESIGNATOR CHART

NOTE:
 REFER TO 889139-001 FOR
 CUSTOMER DESIGNATION CODE.

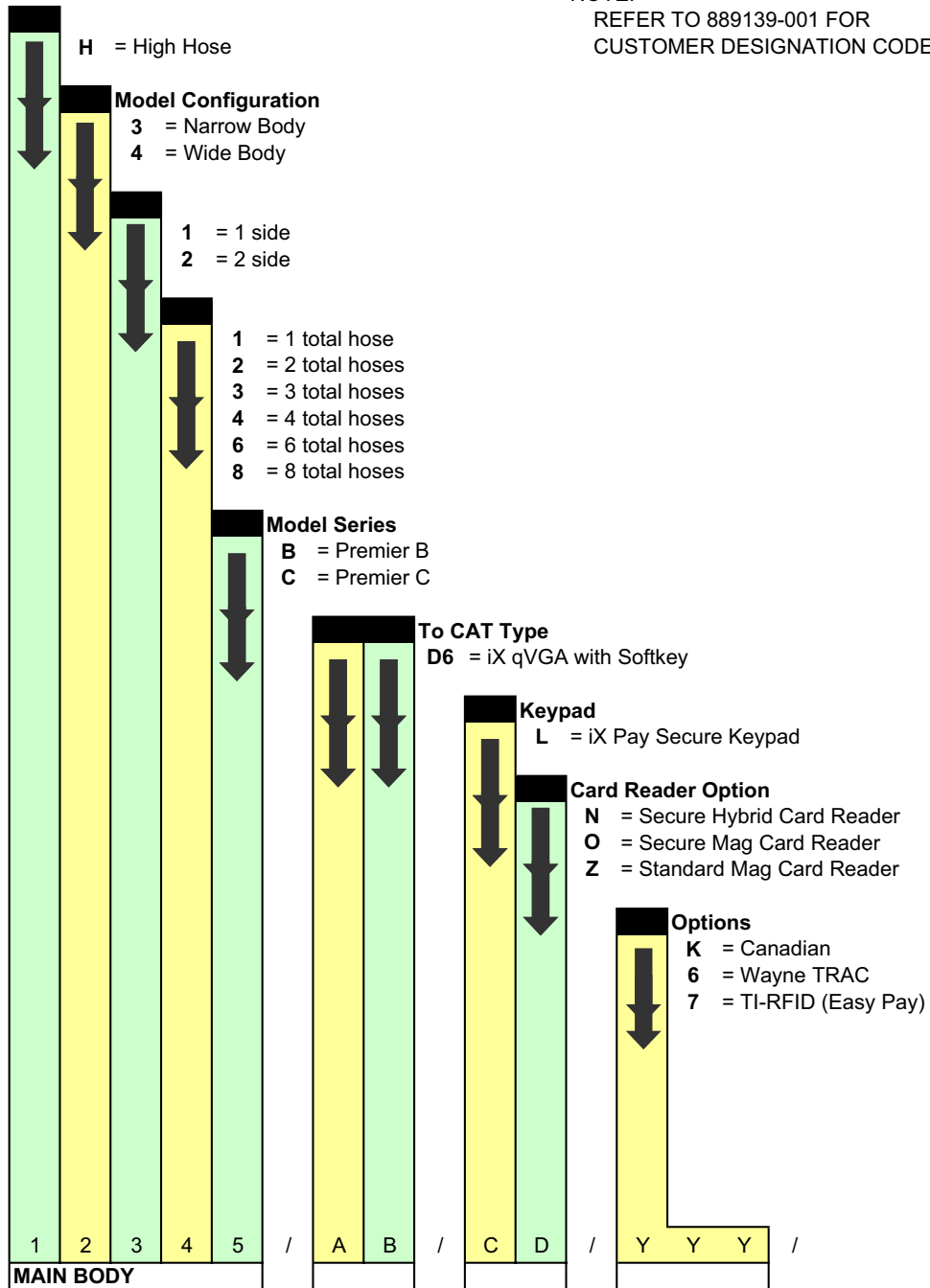

1 INTRODUCTION

This manual provides instructions for installing the iX™ Pay Secure Payment Retrofit Kit in Tokheim Premier C (Wide Body) dispensers. The kits will be configured at the time of order based on the type of dispenser to be retrofitted as defined by the Kit Model Designation Chart on the previous page. The kit part numbers (model numbers) will be in the format 12345/AB/CD/YYY as defined by the chart. This manual applies to kit models x4xxC/ where 4 represents wide body, and C represents Premier C.

Address questions concerning installation of this kit to Wayne Technical Support at 1-800-926-3737.

1.1 Parts Required

The parts and quantities that are included in each kit are shown on the following pages.

1.2 Tools Required

Crimp tool
Wire strippers
Allen and socket wrenches
Screwdrivers and nut drivers

1.3 Safety Precautions

Before beginning the installation of this kit, block off the work area with safety cones.

NOTE: These retrofit kits may require installation of several wiring and hardware assemblies. Any installation or modification must comply with the requirements of the National Electrical Code (NFPA 70), and NFPA 30 and any other applicable codes.

NFPA 30A states that:

“When maintenance to Class 1 dispensing devices becomes necessary and such maintenance may allow the accidental release or ignition of liquid, the following precautions shall be taken before such maintenance is begun:

- Only persons knowledgeable in performing the required maintenance shall perform the work.
- All electrical power to the dispensing device and pump serving the dispenser shall be shut off at the main electrical disconnect panel.
- The emergency shut-off valve at the dispenser, if installed, shall be closed.
- All vehicle traffic and unauthorized persons shall be prevented from coming within 20 ft.(6 m) of the dispensing device. ”



WARNING

Electric shock hazard! More than one disconnect switch may be required to de-energize the dispenser for maintenance and servicing. Use a voltmeter to make sure ALL circuits in the dispenser are de-energized. Failure to do so may result in serious injury.

Lockout/Tagout requirements of the U. S. Dept. of Labor, Occupational Safety and Health Administration (OSHA) may also apply. Refer to Title 29, Part 1910 of the Code of Federal Regulations (29CFR1910), *Control of Hazardous Energy Source (Lockout/Tagout)*.

1. Reprinted with permission from NFPA 30A-90, *Automotive and Marine Service Station Codes*, Copyright ©1990, National Fire Protection Association, Quincy MA 02269. This reprinted material is not the complete and official position of the National Fire Protection Association on the referenced subject, which is represented only by the standard in its entirety.



FIGURE 1 PREMIER C WIDE BODY PARTS.

Prior to installation, inspect the kit and ensure that it contains all the required parts as shown by the item numbers in Figure 1 and listed in Table 1.

Table 1 Parts Included in the Wide Body Kits

Part Number	Description	Qty for Dual Sided	Qty for Single Sided	Item No.
WU001604	iX Pay Secure Payment Door	2	1	1
WU002495-0001	iX Bracket Assembly	2	1	2
WU001031	Secure iX Board Assembly	2	1	3 part of item 2
887223-001	DC Distribution Board	1	1	4 part of item 2
882505-002	#6 Nylon Standoffs	13	8	5 part of item 2
6005901	#6 Screws 3/8	3	2	6 part of item 2
69-55392	1/4-20 Sheet Metal Screws for iX bracket	6	3	7
6019404	#10 Nut	2	2	8
892369-002	Y Power cable - DC Dist to ea iX Board	1	1	9
WU002265-0001	Power cable - Power Supply to DC Dist	1	1	10
WU002090-0001	Y Annunicator cable	1		11
886495-001	Annunicator	1	1	12
WU002266-0001	Cable Data Link (RS485) - short splice cable	1	1	13
WU002091-0001	Cable Data Link (RS485) - long Y cable	1	1	14
4050401	Crimp Wire Connectors	2	2	15
001-916486-	Cable Ties	10	10	16
000-132708-	Washer 1/4-20 Alum for sheet metal screws	6	3	17
000-913632-	Washer, #10 Star	2	1	18
000-131445-	Nylon Washer/Spacer	4	2	19
WU002389-0001	Display Cover Decal	2	1	20
WU002389-0002	Keypad Cover Decal	2	1	21
WU002389-0003	QVGA Display Cover Decal	2	1	22
WU002389-0004	Softkey Cover Decal	4	2	23
002-231841-	Tokheim Bezel Key	1	1	24
000-940043-002	Installation Manual	1	1	not shown

2 INSTALLATION Note: Adhere to the safety precautions listed in Section 1.3

WARNING: DO NOT USE POWER TOOLS WHEN WORKING IN THE HAZARDOUS ZONE.

Turn off power to dispenser at circuit breaker inside the building before starting this procedure.

2.1 Installation Instructions For Tokheim Premier C Wide Body

1. Unlock and open printer door, then unlatch the other two doors. (The latch is behind each door, Figure 2. Open all three upper doors and repeat on opposite side if dual sided dispenser.) Use door/bezel key (002-231841-) provided.
2. Disconnect power at dispenser at AC Distr board J8 AC In connector, Figure 3.
3. Remove hydraulic doors (both sides as applicable).
4. Use 5/16 nut driver to remove the nut and green ground wire from each bezel/door, both sides. Save the nuts.
5. Disconnect all cables from the doors that go into the electronics head.
Note position of cables leading to center door of dispenser as these cables will be reattached later. Remove and save screw securing cable tie to the door and leave cables in place. The cables to be reconnected are shown in Figure 13.
6. Fold back door gasket on upper inside of door to access the hinge pin, Figure 4. Release the pin using a screwdriver and remove door. Repeat for each door. Discard the door that contains the printer/keypad.
7. Remove the (2) outside screws on the ad panel and remove the (4) 3/8 hex head nuts on the inside, then remove ad panel. Save ad panel, nuts and screws. Keep ad panel upright so that nylon washers stay in place.
8. A. Disconnect all cables from the DPT board, Figure 5, and remove cables from the plastic cable holder that is attached to the DPT bracket.
9. Remove and discard the (3) 3/8 Hex head screws that are securing the DPT bracket to the dispenser head chassis and remove the DPT bracket with board. Discard all parts or save as necessary per customer/site scope of work.
10. Repeat steps 5-10 on opposite side if dual sided dispenser.

11. A. Untie wrap and discard all cables that were disconnected from the DPT boards and all cables disconnected from the printer doors, including cables to J16 and J17 on the Motherboard Figure 5 and cable to J3 on DC Power Supply Figure 6.

Note: The cables shown in Figure 13 will be reconnected when the Sales Display door is reinstalled.

- B. The RS485 harnesses must be removed by removing three crimp connectors at the barrel connector, Figure 9. Locate the crimp connectors on the RS-485 wire harness, then remove connectors/cut connectors (Figure 10) and discard harness.

Refer to Figure 7 and Figure 8 during the following steps.

The iX board will be pre-assembled on one of the new iX Brackets with the RS485 and Ethernet connectors at the top.

The DC Dist board will be pre-assembled on the opposite side of this bracket with the 6-pin connector at the top.

12. Install iX Bracket into the dispenser using (3) Alum washers 000-132708 and (3) Sheet Metal Screws 69-55392.
The iX bracket (with the DC Dist board) is installed on the side closest to the existing Power Supply J3 connector shown in Figure 6. A completed installation is shown in Figure 8.
13. If dual sided dispenser, install the 2nd iX Bracket into opposite side of dispenser using (3) Alum washers 000-132708 and (3) Sheet Metal Screws 69-55392.
14. Reinstall the ad panel reusing the (4) nuts on the inside of the head frame and (2) screws on the outside of the panel.
15. A. Reinstall the right and center doors by placing the bottom of the door on the ad panel pin and use a screwdriver to lower the top hinge pin and snap in place. Then return door gaskets to their original position.

B. Reconnect the ground wire to each door reusing the nuts.

C. Reconnect the (3) cables to the Sales Display door shown in Figure 13.
16. A. On the left side of the ad panel, remove and discard the existing nylon washers (spacers) from the door pin and install (2) new Nylon Washers (000-131445-).

B. Install (1) SPM Secure Payment Door assembly (WU001604) left door in similar manner as the other doors, placing the bottom of door onto the ad panel pin first, folding back gasket in upper right corner and inserting upper pin.

17. Refer to Figure 8, and connect the cables from the SPM assembly as follows:
 - A. Secure gold-colored ground strap to the inside chassis, see Figure 8, using (1) #10 Washer 000-913632 and (1) #10 Nut 6019404.
 - B. QVGA Cable (888798-) to the iX board (J20) Port #1.
 - C. USB cable (892139-002) to the “USB 1” connector on the iX Board.
 - D. Printer power cable (880566-002) to the 6-pin Printer 1 connector on the DC Dist board.
 - E. SPM 2-pin Power cable (890680-002) to either of the 2-pin connectors on the DC Dist board.
18. Repeat above Steps 14-17 on opposite side if dual sided dispenser.
19. Connect Y Power cable (892369-002) to any of the spare 2-pin connectors on the 24V DC Dist. board and to each iX board 6-pin Power connector. On dual sided, route the cable through the existing cable holders/retainers when routing to the opposite side.
20. Connect Power cable (WU002265-0000 to J3 on the DC Power supply (Figure 6) and to J1 on the DC Dist board.
21. Connect RS485 Y cable (WU002091-0001) to each iX board (J19 Port #3) and connect the other end to the new (WU002266-0001) RS485 short cable.
22. Route the end of the above (WU002266) cable over to the existing RS485 (Blue, Orange and Yellow) wires that were disconnected from barrel connector in step 11.

Strip the Blue and Yellow wires.
As shown in Figures 11 and 12, use Crimp Connectors (4050401) and crimp as follows:
(RS485+) Blue wire to the (WU002266) Brown wire
(RS485-) Yellow wire to the (WU002266) Violet wire.
23. Unscrew the cover on the Annunciator (886495-001) and insert annunciator into the hole on the iX bracket and re-secure the cover.
24. If dual sided dispenser, connect Annunciator Y cable (WU002090-0001) to the Annunciator and to both iX boards J18 Annunciator connector located in the lower center of the board.
If single sided dispenser, connect Annunciator directly to J18 on the iX board.
25. Bundle all cables where possible, using Cable Ties (001-916486-). Ensure cables are routed away from sharp edges.
26. Ensure that cables are secured to the doors and safely secured inside the head.

27. Reconnect AC power to the AC Dist board J8.
28. Close and latch/lock the Sales Display door and the Secure Payment door (both sides as applicable).
29. Cover the old displays, keypads, softkeys as applicable using (items 20-23) Decal Covers (WU002389).
30. Reinstall hydraulic doors (both sides as applicable).
31. Turn circuit breaker on to the dispenser.
32. Follow the procedures in the SPM Startup manual (940014) to test and place the SPM into operation. Verify SPM and dispenser operation.

Note: Printer should be set to 115K Baud Rate. If printer does not print configuration report, check jumpers on back of the Clamshell printer. The top jumper should be across the two pins and the bottom jumper moved to the left (not across the pins).

Note: See service memo SM09-02 for Verifone POS settings.



FIGURE 2

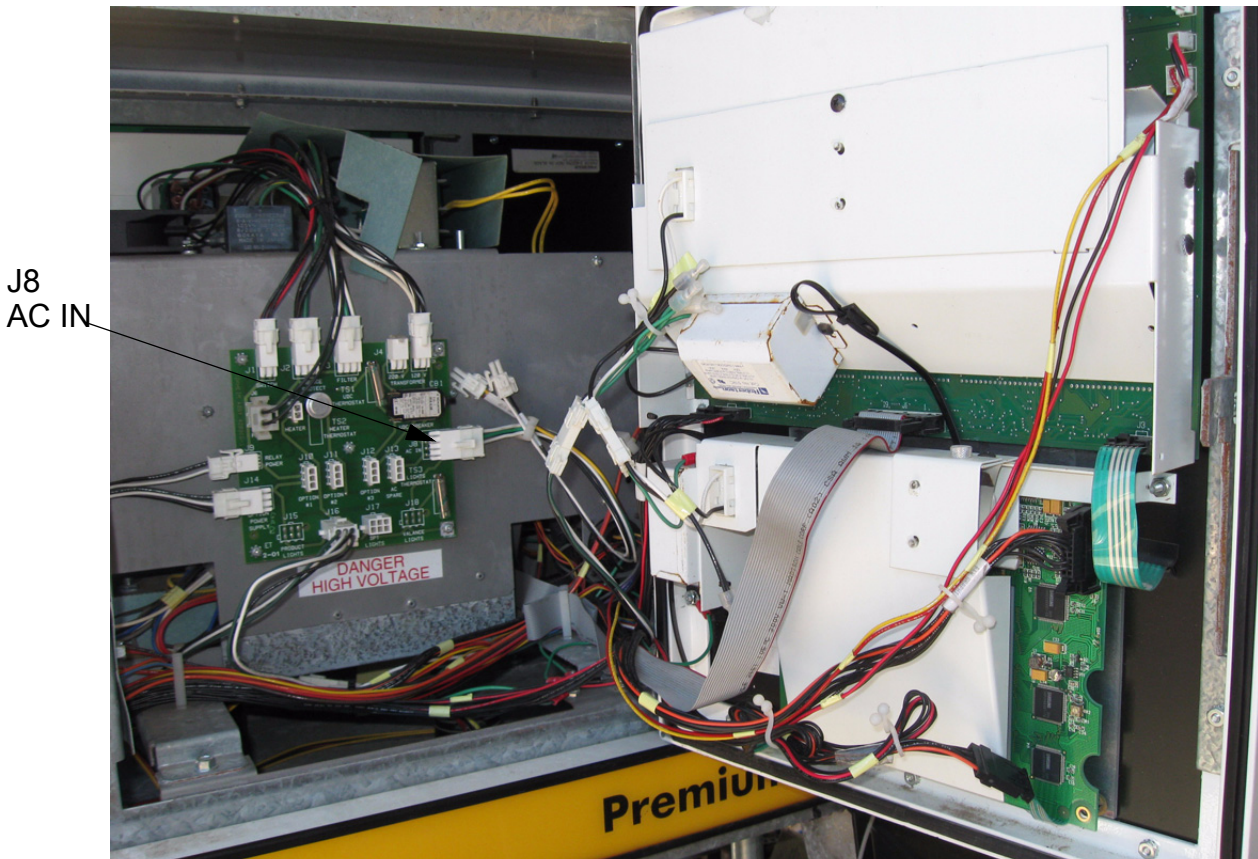
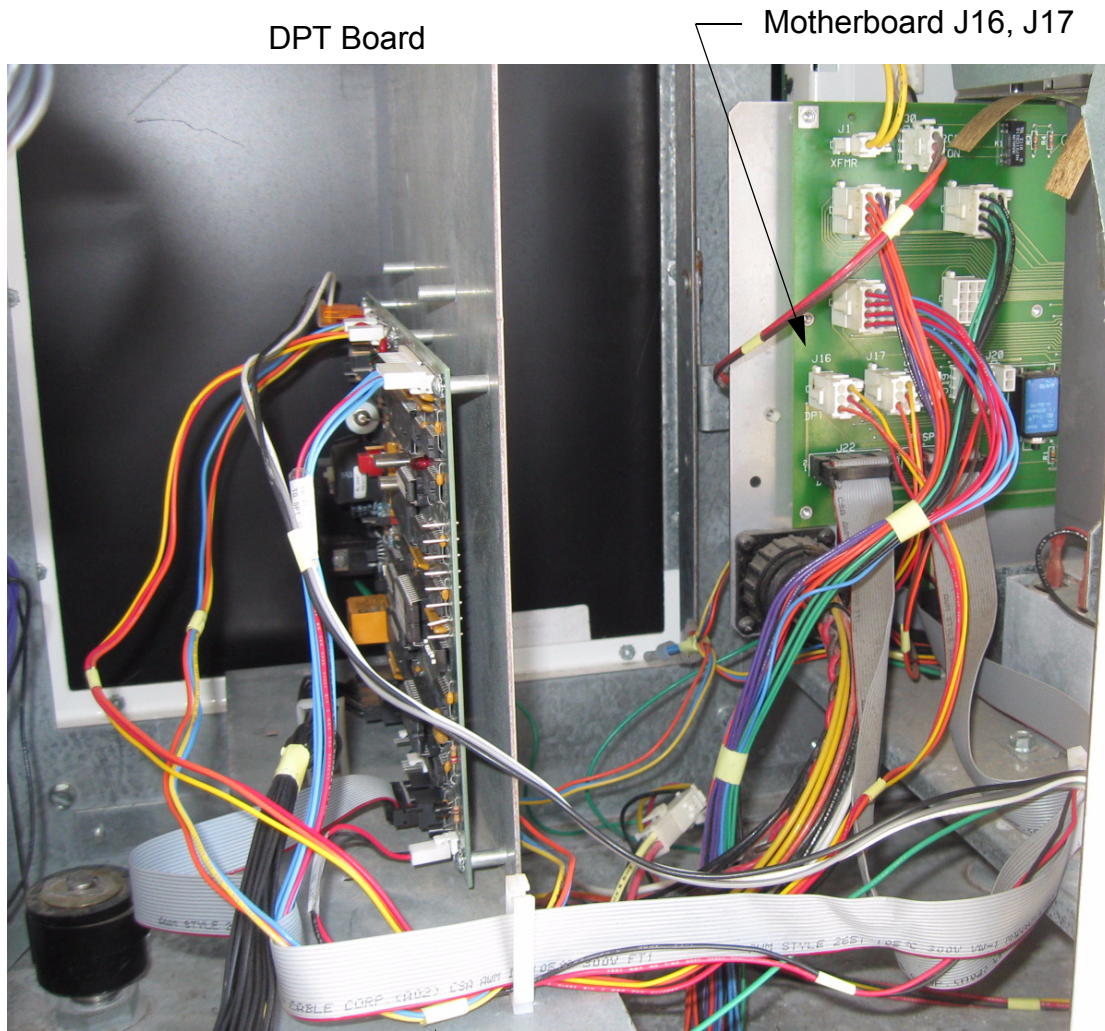

FIGURE 3

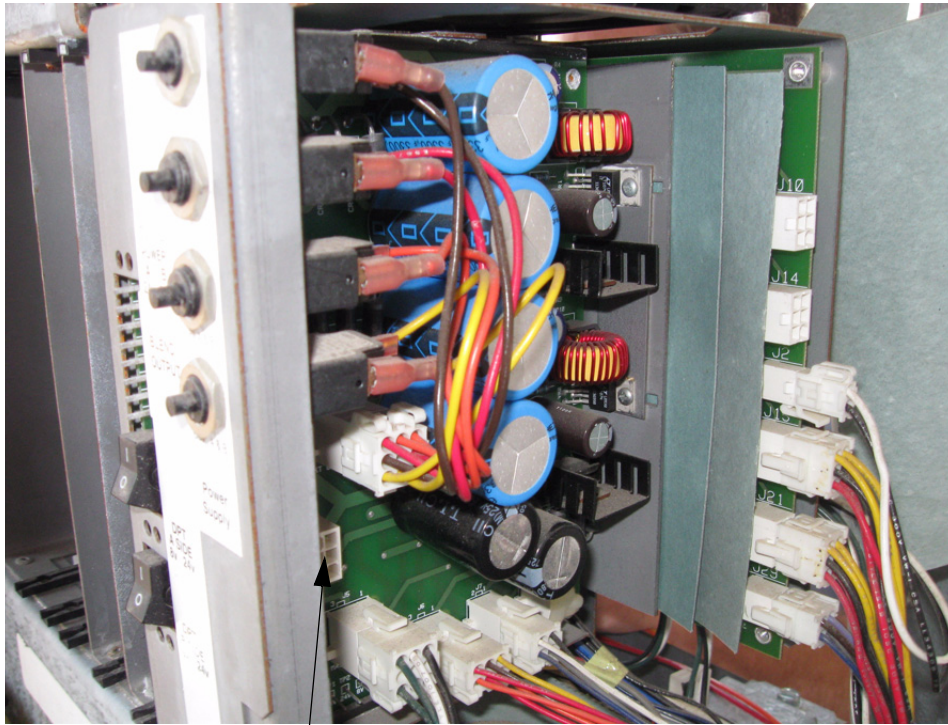

FIGURE 4



DPT Board
Motherboard J16, J17
DPT Bracket
(2) Hex screws on one side, (1) Hex screw opposite side

FIGURE 5



DC Power Supply J3

FIGURE 6

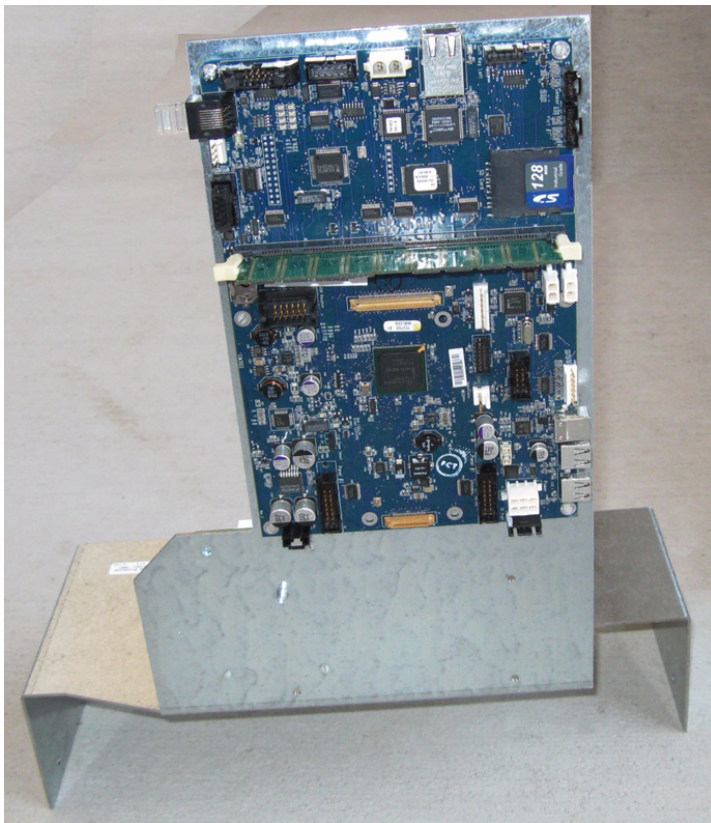

iX Board

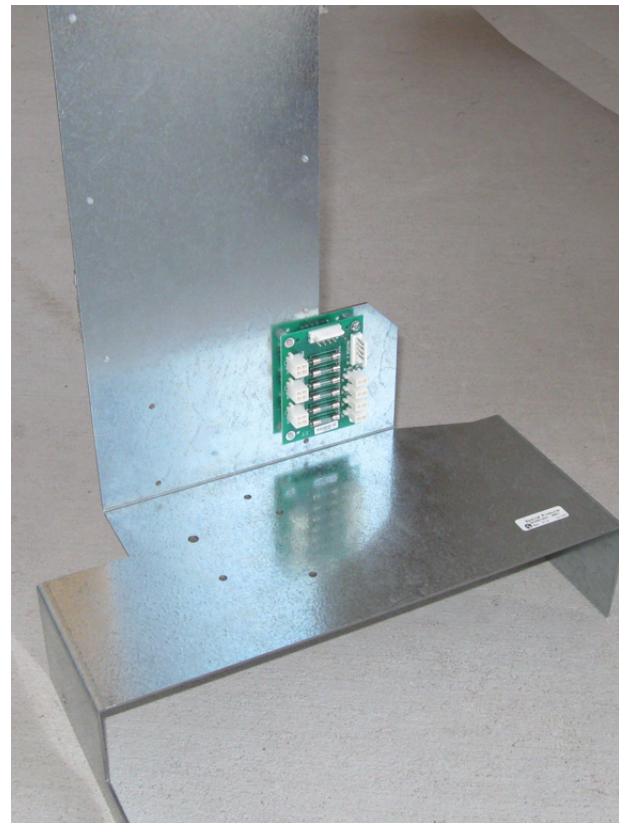

DC Dist Board

FIGURE 7

Existing
Power
Supply
J3

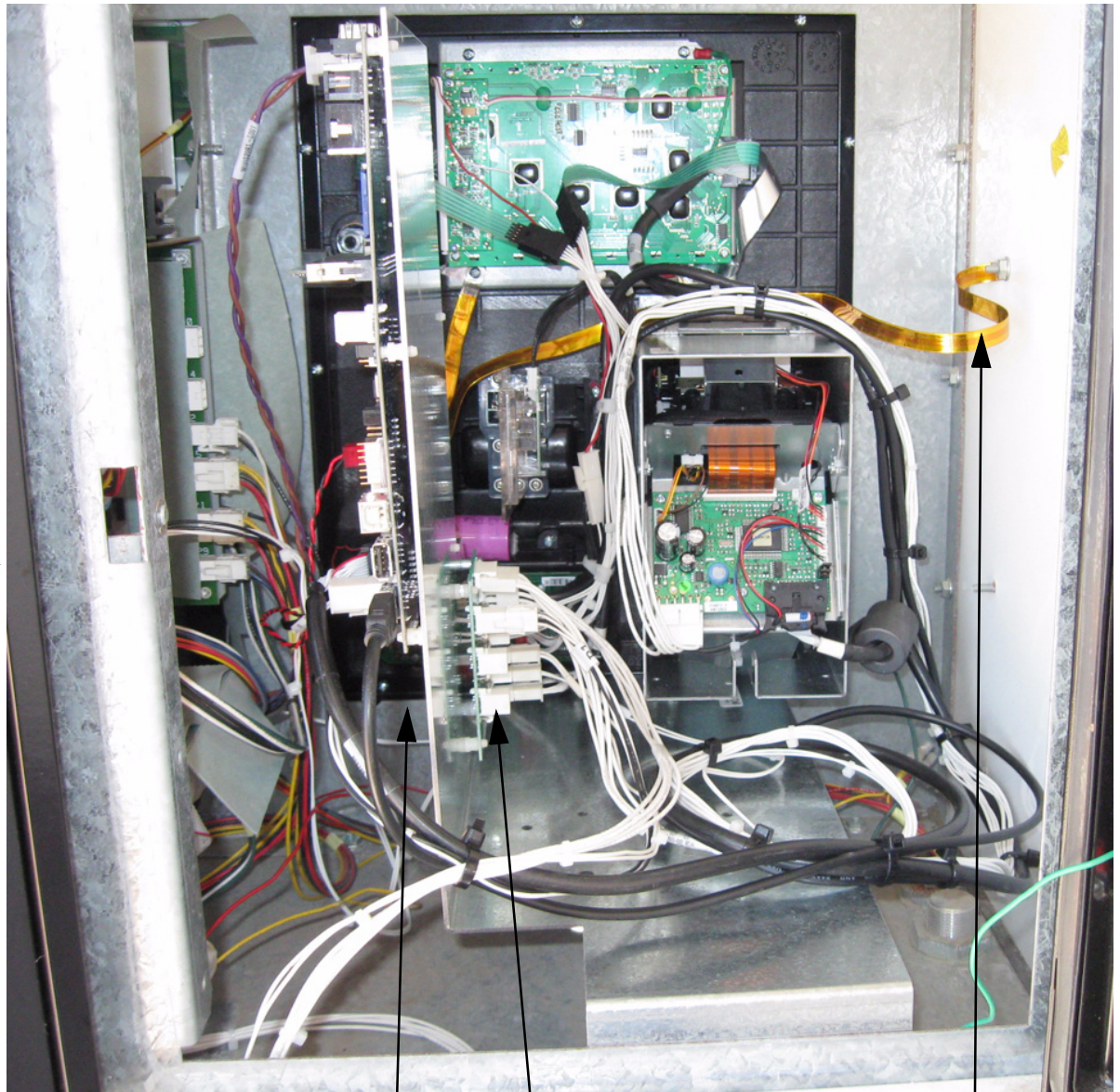

IX BOARD

DC DIST BOARD

SPM GROUND
STRAP TO CHASSIS

FIGURE 8

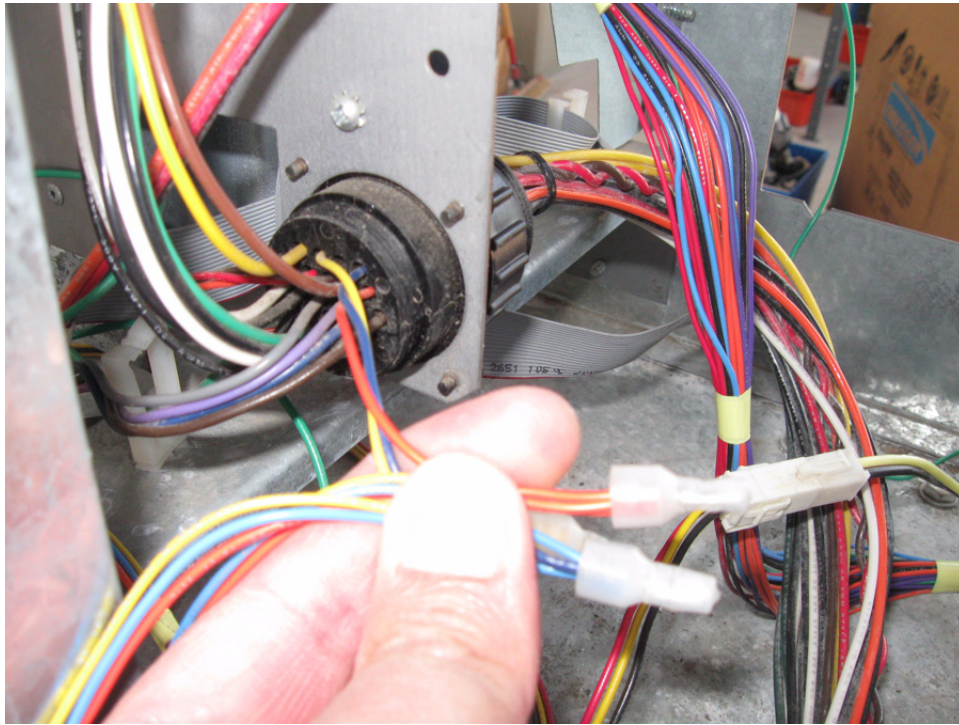

FIGURE 9

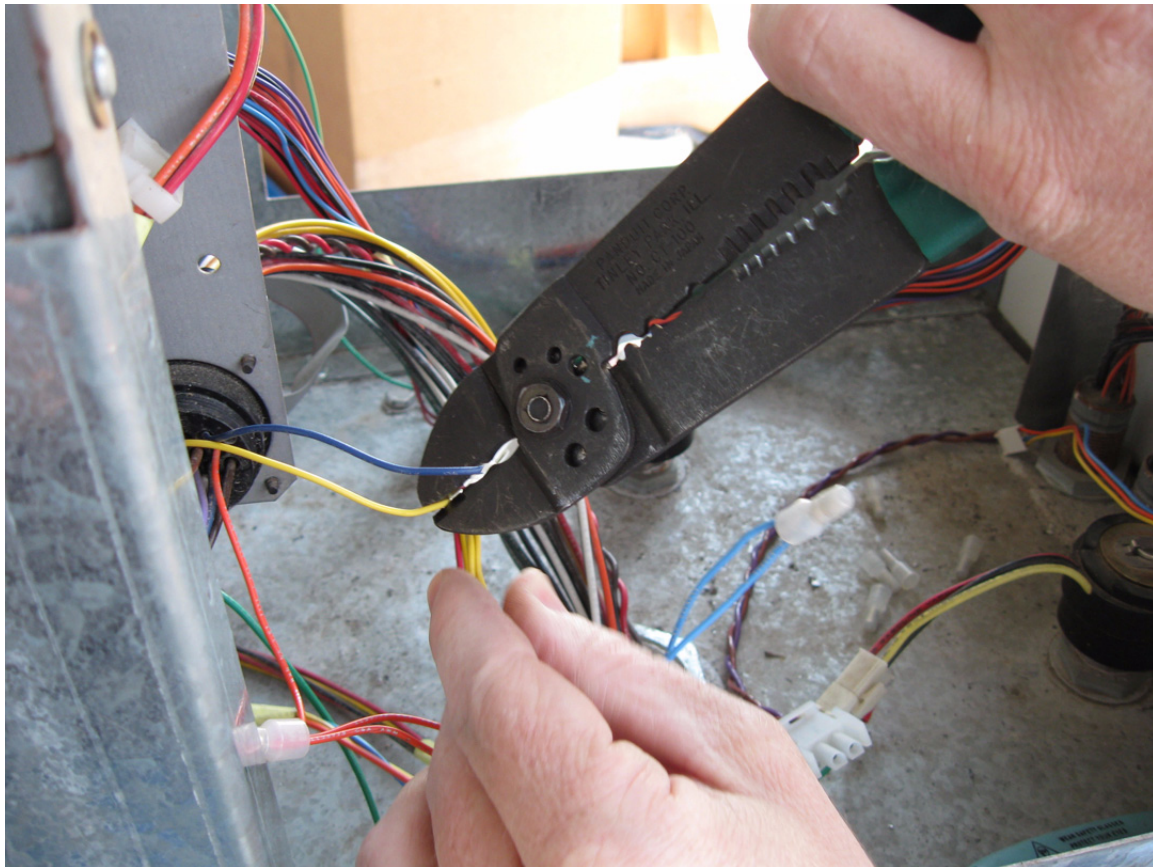

FIGURE 10

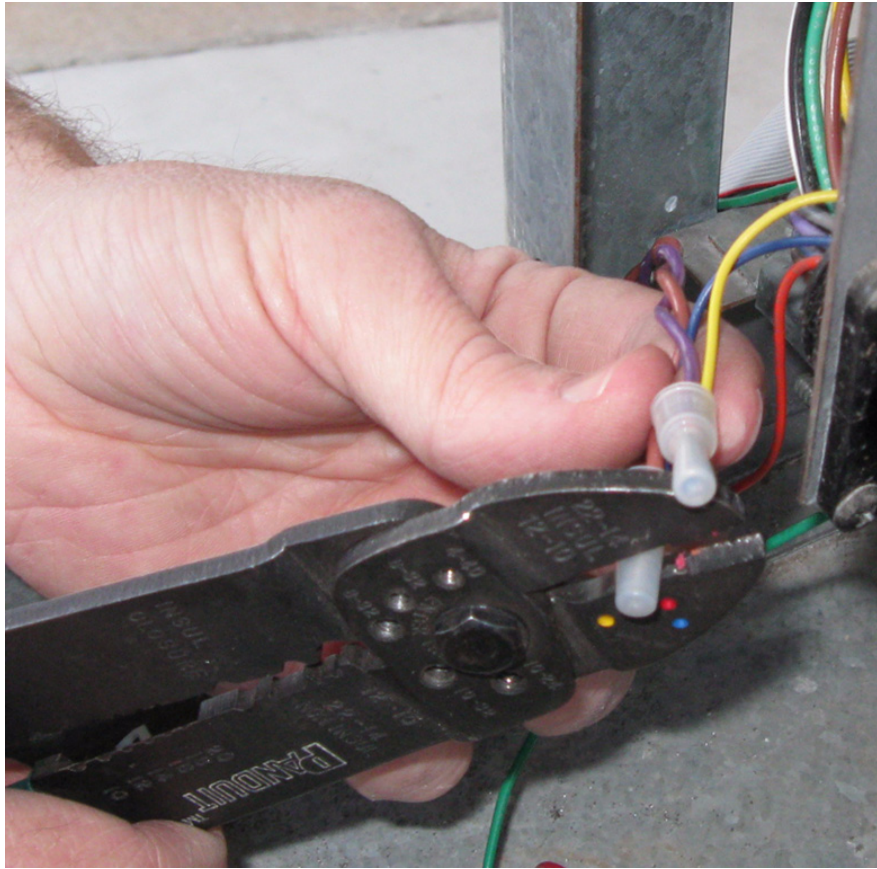

FIGURE 11

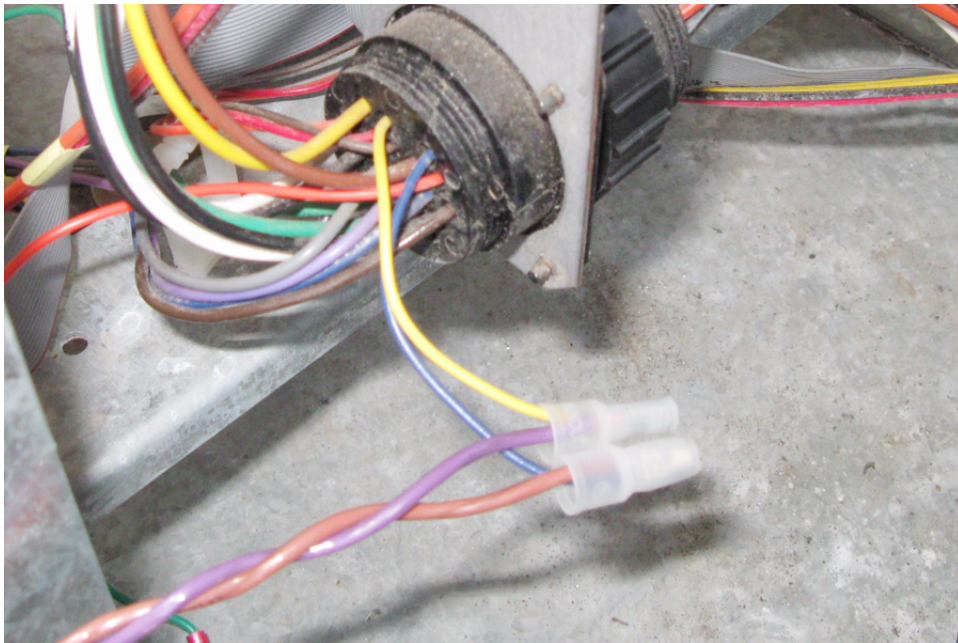
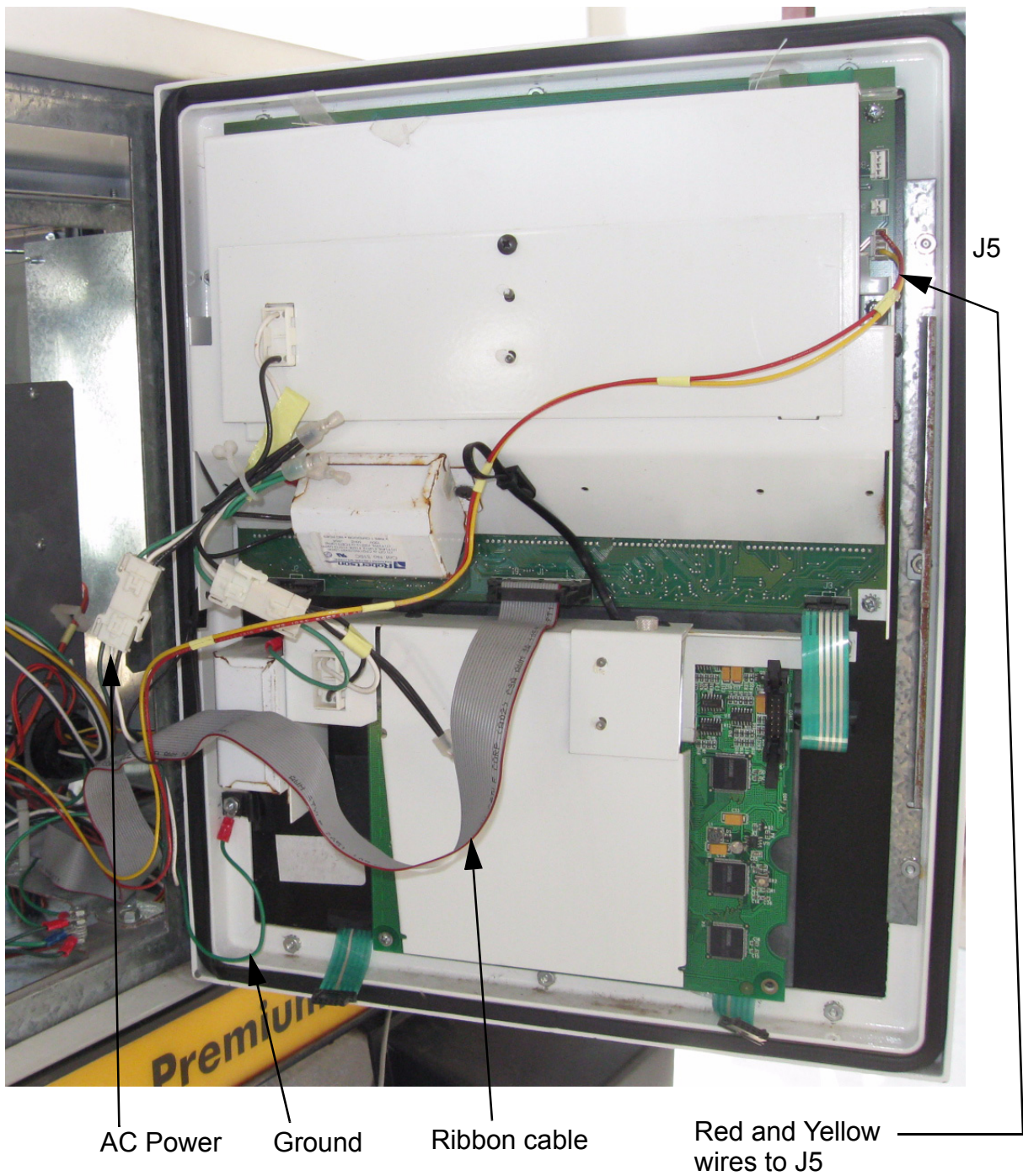

FIGURE 12



Only these cables will be reconnected to the Sales Display door assembly.

FIGURE 13

Tokheim Premier B & C SPM Retrofit Wiring Diagram

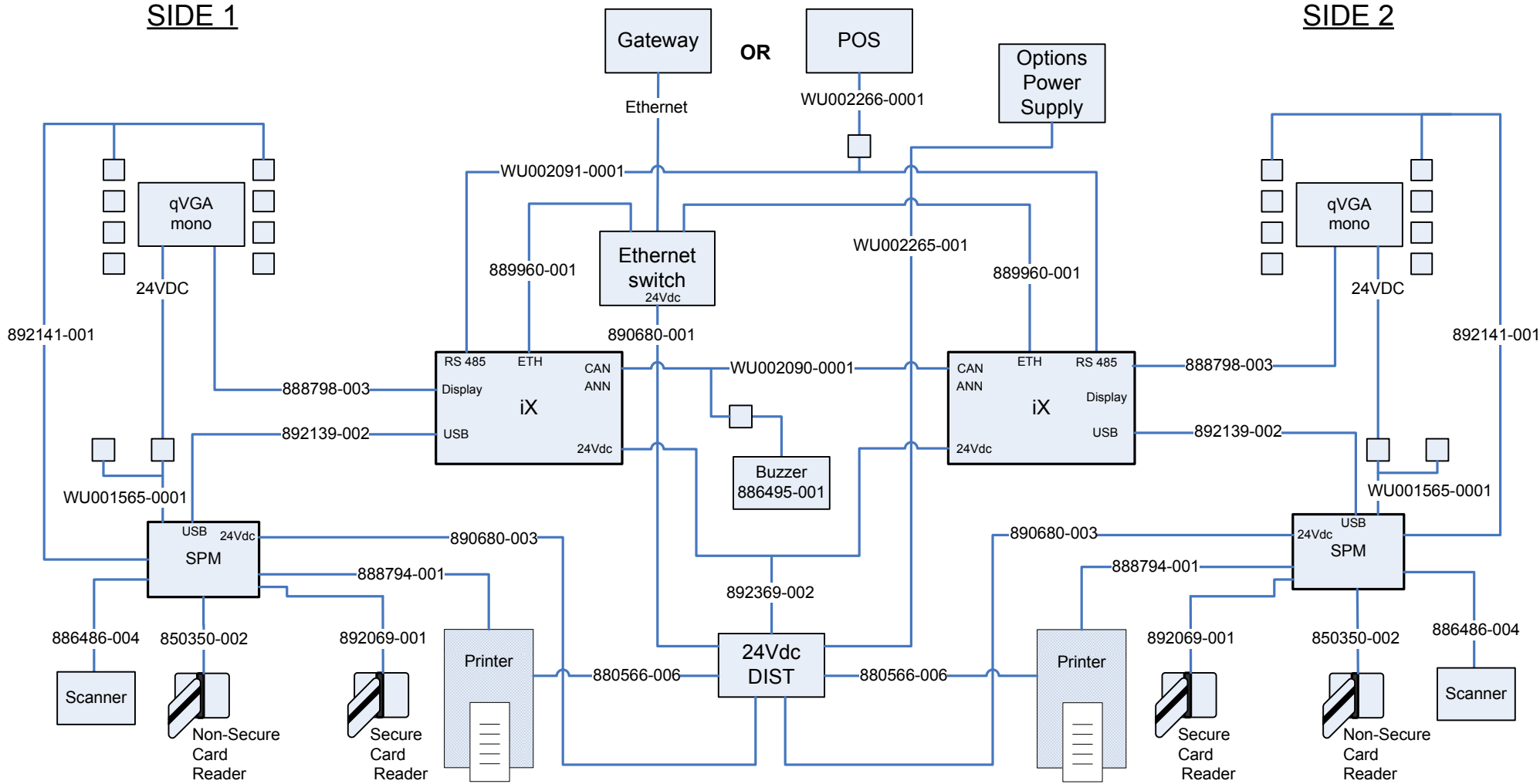

INSTALLATION MANUAL

iX Pay Retrofit Kits for Premier C Wide Body Dispensers

Written by S. G. Martin

This manual was produced using Adobe® FrameMaker® and Photoshop®

Page design uses Arial Fonts

Copyright © 2009 Dresser, Inc.
All rights reserved.
Printed in the United States of America.

Adobe® FrameMaker® and Photoshop® are trademarks of Adobe Systems, Inc.

This manual and the software described within are furnished under license and may be used or copied only in accordance with the terms of such license.

No part of this publication may be electronically or mechanically reproduced, stored in a retrieval system, or transmitted, in any form or by any means, except as permitted by such license. Translation of this material to another language without express written permission of Dresser, Inc. is prohibited.

The information in this publication is for informational use only and is subject to change without notice. The contents should not be construed as a commitment by Dresser, Inc. who assumes no responsibility or liability for inaccuracies that may appear in this publication.

**Dresser Wayne, Dresser, Inc., is located at 3814 Jarrett Way, Austin TX 78728.
Wayne's general telephone number is (512)-388-8311.**

NOTE: "This equipment has been tested and found to comply with the limits for a Class A digital device, pursuant to Part 15 of the FCC Rules. These limits are designed to provide reasonable protection against harmful interference when the equipment is operated in a commercial environment. This equipment generates, uses, and can radiate radio frequency energy and, if not installed and used in accordance with the instruction manual, may cause harmful interference to radio communications. Operation of this equipment in a residential area is likely to cause harmful interference in which case the user will be required to correct the interference at his own expense."

