

# SERVICE

3/Vista Series  
Blending and  
Non-Blending  
Dispensers





## READ THIS MANUAL BEFORE YOU BEGIN

Dispensers have both electricity and a hazardous, flammable and potentially explosive liquid. Failure to follow the below precautions and the Warning and Caution instructions in this manual may result in serious injury. Follow all rules, codes and laws that apply to your area and installation.

### SAFETY PRECAUTIONS - INSTALLATION AND MAINTENANCE

Always make sure ALL power to the dispenser is turned OFF before you open the dispenser cabinet for maintenance. Physically lock, restrict access to, or tag the circuit breakers you turn off when servicing the dispenser. Be sure to trip (close) the emergency valve(s) under the dispenser BEFORE beginning maintenance.

Make sure that you know how to turn OFF power to the dispenser and submersible pumps in an emergency. Have all leaks or defects repaired immediately.

### EQUIPMENT PRECAUTIONS

Be sure to bleed all air from product lines of remote dispensers and prime suction pumps before dispensing product, otherwise, damage to the equipment may occur. Always use the approved method for lifting the dispenser. Never lift by the nozzle boot, sheet metal, valance, etc., otherwise equipment damage or personal injury may occur.

### HOW TO CONTACT WAYNE

Trouble with the installation and operation of the dispenser should be referred to your authorized Wayne service personnel or Wayne Technical Support (1-800-926-3737).

### INDICATORS AND NOTATIONS

**DANGER**

Danger indicates a hazard or unsafe practice which, if not avoided, will result in severe injury or possibly death.

**WARNING**

Warning indicates a hazard or unsafe practice which, if not avoided, may result in severe injury or possibly death.

**CAUTION**

Caution indicates a hazard or unsafe practice which, if not avoided, may result in minor injury.

**NOTE:**

Important information to consider, otherwise, improper installation and/or damage to components may occur.

3/Vista Series  
Blending and  
Non-Blending  
Dispensers

**Service**



# Table of Contents

| <u>Title</u>   | <u>Page</u> |
|--|-------------|
| 1. INTRODUCTION . . . . .  | 1           |
| 1.1. Regional Service Offices . . . . .                          | 2           |
| 2. OPERATION . . . . .   | 3           |
| 2.1. Lift-to-Start Models . . . . .                              | 3           |
| 2.2. Push-to-Start Models . . . . .                              | 3           |
| 2.3. Setting Unit Prices . . . . .                               | 4           |
| 2.4. Setting Blend Ratios . . . . .                              | 6           |
| 2.5. Setting Fueling Point ID . . . . .                          | 7           |
| 2.6. Authorizing The Dispenser . . . . .                         | 7           |
| 3. ELECTRONIC PARTS . . . . .                                    | 9           |
| 3.1. Electronic Spare Parts List . . . . .                       | 9           |
| 4. MECHANICAL PARTS . . . . .                                    | 11          |
| 4.1. Nozzle Boot . . . . .                                       | 11          |
| 4.1.1. Lift-to-Start Version . . . . .                           | 11          |
| 4.1.2. Push-to-Start Version . . . . .                           | 11          |
| 5. HYDRAULIC PARTS . . . . .                                     | 13          |
| 5.1. Strainer and Filter . . . . .                               | 13          |
| 5.1.1. Strainer . . . . .  | 13          |
| 5.1.2. Filter . . . . .  | 13          |
| 5.2. Proportional Flow Control Valve . . . . .                   | 15          |
| 5.2.1. Flow Control Valve “Off” No Flow . . . . .                | 16          |
| 5.2.2. Flow Control Valve “On” Slow Flow . . . . .               | 16          |
| 5.2.3. Flow Control Valve “On” Full Regulated Flow . . . . .     | 17          |
| 5.3. iMeter . . . . .  | 17          |
| 5.3.1. Check and Pressure Relief Valve . . . . .                 | 17          |
| 5.4. Double Bump Tubing . . . . .                                | 19          |
| 6. PROGRAMMING FUNCTIONS AND STATISTICS . . . . .                | 21          |
| 6.1. Entering Maintenance Mode Via IR Remote Control . . . . .   | 21          |
| 6.2. Function Programming . . . . .                              | 23          |
| 6.3. Statistics . . . . .  | 35          |
| 6.4. Weights and Measures Mode . . . . .                         | 41          |
| 7. TROUBLESHOOTING, ERROR CODES AND SOLUTIONS . . . . .          | 43          |
| 7.1. Using the IR Remote to View Statistics . . . . .            | 43          |
| 7.2. Using the Service Terminal Program (STP) . . . . .          | 43          |
| 8. PROCEDURES FOR UPLOADING AND DOWNLOADING FILES . . . . .      | 51          |
| 8.1. Uploading and Downloading Pump Code and Templates . . . . . | 53          |
| 8.2. Bootstrap Procedure . . . . .                               | 54          |
| 9. ELECTRONIC BOARDS - INDICATORS, LAYOUTS AND PINOUTS . . . . . | 55          |
| 9.1. Computer Board LED Indicators . . . . .                     | 56          |
| 9.2. Computer Board Connector Pinouts . . . . .                  | 58          |
| 9.3. ISB Board Assy Pinouts . . . . .                            | 63          |
| 9.4. 24V DC Distribution Board Pinouts . . . . .                 | 66          |
| 9.5. Relay Board Pinouts . . . . .                               | 68          |
| 9.6. Wayne Vac Control Board Pinouts . . . . .                   | 70          |
| 9.7. Display Board Pinouts . . . . .                             | 72          |
| 9.8. 24V Power Supply Assy Pinouts . . . . .                     | 73          |
| 9.9. Dual CAT Board Pinouts . . . . .                            | 74          |

## Table of Contents

| <u>Title</u>   | <u>Page</u> |
|--|-------------|
| 10. REPLACEMENT PROCEDURES . . . . .                       | 75          |
| 10.1. Computer Board Replacement . . . . .                 | 78          |
| 10.2. ISB Assy Replacement . . . . .                       | 79          |
| 10.3. 24V DC Distribution Board Replacement . . . . .      | 79          |
| 10.4. Relay Board Replacement . . . . .                    | 80          |
| 10.5. 24V Power Supply Replacement . . . . .               | 80          |
| 10.6. Electro-Mechanical Totalizer Replacement . . . . .   | 80          |
| 10.7. Display Board Replacement . . . . .                  | 81          |
| 10.8. Dual CAT Board Replacement . . . . .                 | 81          |
| 10.9. Wayne Vac Control Board Replacement . . . . .        | 81          |
| 10.10. Pulser Replacement . . . . .                        | 82          |
| 10101 Pulser Mode Setting and iMeter Calibration . . . . . | 83          |
| 10.11. Proportional Valve Assy Replacement . . . . .       | 86          |
| 10.12. iMeter Replacement . . . . .                        | 87          |
| 10.13. Check Valve Replacement . . . . .                   | 88          |
| 11. PRESET PROGRAMMING . . . . .                           | 89          |
| 12. WIRING DIAGRAMS . . . . .                              | 95          |

## 1. INTRODUCTION

This manual describes the service of Wayne Vista series blending and non-blending dispensers that have a "3" in the prefix of the model number. For example, 3/V390D1/GQUY. Again, these dispensers can be identified by their model which begins with "3/V", hereafter, referred to as 3/Vista models. The basic troubleshooting methods and service theory will remain the same for all models of dispensers which satisfy the above definition. Any information which is specific to a particular model of dispenser will be shown as specific in the text.

Non-blending dispensers included in this manual are the 3/V387, 3/V388, 3/V389, 3/V390, 3/V399 and 3/V490 models. Non-blending dispensers do not combine base products. These dispensers are multi-grade dispensers, except for the 3/V387 single grade model.

Blending dispensers included in this manual are the 3/V580, 3/V585, 3/V590, 3/V591, and 3/V595 models. Blending dispensers combine the base products to provide a blended grade or grades. Blending dispensers have two base products labeled LO and HI. These base products may be dispensed individually and/or combined into one or more blended grades. The 3/V591 and 3/V595 models also have an additional single-product (unblended) grade, however, the 3/V595/U does not.

3/Vista series dispensers have a new computer - and associated boards - and a sales display board mounted on the back of the new bezel.

The new computer in 3/Vista series dispensers controls the hydraulic module that was newly designed and introduced in the 2/Vista series. The hydraulic module consists of the **iMeter Module** and the **Intelligent Pulser**. The iMeter Module is two meters in one assembly and contains the **Intelligent Pulser**.

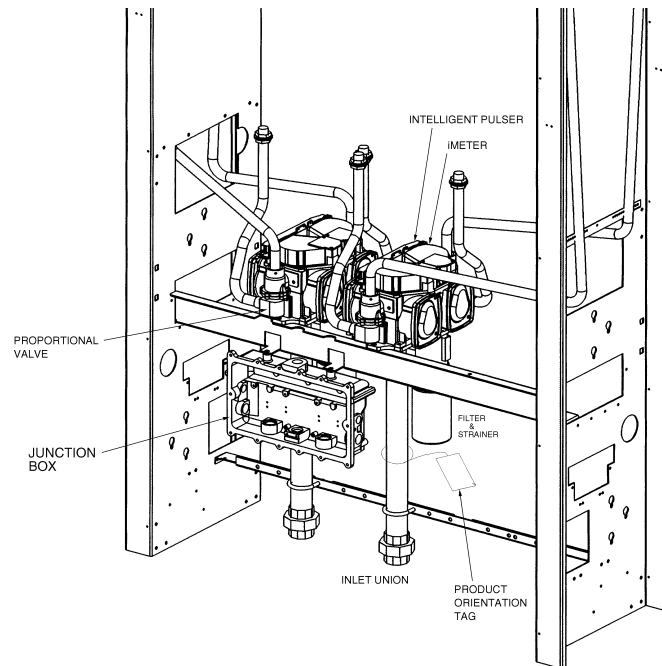

**FIGURE 1-1. 3/VISTA DISPENSER.** *Proportional valves are mounted at the iMeter outlet on 3/Vista model dispensers.*

## 1.1. REGIONAL SERVICE OFFICES

Any service problems that cannot be solved should be referred to Wayne Technical Support or to the appropriate regional service office.

|  |  |
|--|--|
| Wayne Technical Support<br>Austin, TX                    | 1-800-926-3737<br>24 hours/7 days      |
| Northeast Regional<br>Service Office<br>Salisbury, MD    | 410-546-6750<br>8:30AM-5:00 PM Eastern |
| Southeast Regional<br>Service Office<br>Atlanta, GA      | 770-926-6005<br>8:30AM-5:00PM Eastern  |
| North Central Regional<br>Service Office<br>Chicago, IL  | 773-693-7404<br>8:30AM-5:00PM Central  |
| South Central Regional<br>Service Office<br>Houston, TX  | 281-871-5442<br>8:30AM-5:00PM Central  |
| Southwest Regional<br>Service Office<br>Cypress, CA      | 714-952-1137<br>8:30AM-5:00PM Pacific  |
| Northwest Regional<br>Service Office<br>San Ramon, CA    | 510-328-0400<br>8:30AM-5:00PM Pacific  |
| Mid-Atlantic Regional<br>Service Office<br>Baltimore, MD | 410-691-2200<br>8:30AM-5:00PM Eastern  |

## INTERNATIONAL OFFICES

|   |  |
|---|--|
| Caribbean and Latin America<br>Service Office<br>Austin, TX USA | (Voice) 512-388-8624<br>(FAX) 512-388-8643     |
| Mid-East and Africa<br>Service Office<br>United Kingdom         | (Voice) 44-1635-874881<br>(FAX) 44-1635-876633 |
| Far East<br>Service Office<br>Singapore                         | (Voice) 65-422-2397<br>(FAX) 65-225-6604       |



## 2. OPERATION

The operation for all 3/Vista series dispensers is similar, except where distinguished below between lift-to-start and push-to-start models.

Before the dispenser will reset unit prices must be set and an authorization signal must be received, and if a blender model, blend ratios must be set. The unit prices, authorization, and blend ratios can be manually set at the dispenser for stand-alone operation, or from a control system, after first setting the fueling point ID.

The above requirements are discussed in detail in this section. Once they have been satisfied, the dispenser operates as described in the following sections.

### 2.1. LIFT-TO-START MODELS

- When the nozzle is removed from the nozzle boot and the lever is lifted, the constant +5 VDC that the computer supplies to the nozzle switch goes to ground. This signals the computer to begin its reset cycle.
- When the dispenser receives an **Authorization** signal either from the control system or, if stand-alone, from the dispenser, the correct submersible pump relay will be energized.
- The computer performs a self test and flashes eights, blanks, then resets to zeros, on the main sale display.
- After the dispenser resets, the proportional flow control valve (or valves if a blender model) is energized with just enough current to barely open the valve and allow a slow flow.  
After a small amount of fuel has been dispensed, the valve is energized with enough current to be in the fully open position and allow fast flow. During the sale, the valve will be continuously controlled with the proper amount of current to limit fuel flow rate to a maximum of 10 GPM<sup>\*</sup>, and if a blender model, provide the correct blend ratio.
- In preset sales, the current received by the proportional flow control valve(s) is reduced to the barely open position just prior to the final shut-off amount. The valve(s) is then de-energized when the final amount is reached.
- When the lever is lowered, the nozzle switch goes back to the constant +5 VDC, the sale is complete, and the nozzle is returned to the nozzle boot.

### 2.2. PUSH-TO-START MODELS

- When the nozzle is removed from the nozzle boot, the constant +5 VDC that the computer supplies to the nozzle switch goes to ground. At this point, one of the lighted buttons (grade select, cash/credit, or push-to-start, depending model) will flash indicating that one of the buttons must be pressed.
- When one of the lighted buttons is pressed the constant +5 VDC that is supplied to the switch goes to ground. This signals the computer to begin its reset cycle.
- When the dispenser receives an **Authorization** signal either from the control system or from the Authorize switch in the dispenser, the correct submersible pump relay will be energized.

---

\* The maximum allowable flowrate in the United States is 10 gallons per minute.

- The computer performs a self test and flashes eights, blanks, then resets to zeros, on the main sale display.
- After the dispenser resets, the proportional flow control valve (or valves if a blender model) is energized with just enough current to barely open the valve and allow a slow flow.

After a small amount of fuel has been dispensed, the valve(s) is energized with enough current to be in the fully open position and allow fast flow. During the sale, the valve(s) will be continuously controlled with the proper amount of current to limit fuel flow rate to a maximum of 10 GPM, and if a blender model, provide the correct blend ratio.

The maximum allowable flow rate in the U.S. is 10 gallons per minute.

- In preset sales, the current received by the proportional flow control valve(s) is reduced to the barely open position just prior to the final shut-off amount. The valve(s) is then de-energized when the final amount is reached.
- When the nozzle is returned to the nozzle boot, the nozzle switch goes back to the constant +5 VDC and the sale is complete.

### 2.3. SETTING UNIT PRICES

The procedure below is used to set the dispenser unit prices when operating in stand alone mode or when communication with the POS system is disabled. When the dispenser is controlled by the POS, the system will not allow price setting at the dispenser.

The dispenser model template and assigns logical nozzle numbers to the hose positions as shown in (Table 2-1). To set unit prices on side 1 and side 2, functions **F03** and **F04** are accessed using the remote control interface. Sub-function **F03.0N** is accessed to set Credit prices and **F03.1N** for Cash prices, where *N* is the logical nozzle number. Active values of *N* are given in Table 2-1. For side 2, the corresponding sub-functions are **F04.0N** and **F04.1N**, respectively.

#### To access and set Unit Price for Side 1:

1. Press **ENTER**  
*PASS 1* (enter password)
2. Press **ENTER**  
*PASS 2* (enter password)
3. Press **ENTER**. The unit price display will show *F--* (dashes means enter numbers to proceed)
4. Enter **03** to access function F03
5. Press **ENTER**. The unit price display shows *F03* (meaning the function has been accessed)
6. Press **ENTER** to access the sub-functions of F03. The unit price display will show *3.01*.  
The volume display shows the existing unit price and the money display shows --- dashes.
7. Press # key and enter the new unit price or press **NEXT** to go to next nozzle 3.02 and repeat.
8. Press **ENTER** and enter **00** to access function F00 to save the changes.
9. Change the 1 to a **3** with the **UP** key (or enter 3) to save changes and press the **ENTER** key.  
The volume display will show the 3.
10. Press **ENTER**. The display will show *CHANGE STORED* momentarily and then return to normal in a few seconds. When it does, the unit price displays will show the new prices. If they do not show the desired unit prices, access the appropriate sub-function to verify the unit price data.

4 End

Note:

Pressing the NEXT key will advance to the next sub-function, incrementing the value of *N* by (.01). For example, to access F3.02, press **NEXT**. The unit price display will show 3.02, *press NEXT*. The desired sub-function depends on the dispenser type. Table 2-1 shows the values of *N* that define the desired sub-functions for the dispensers shown. Once the desired sub-function is accessed, the money display will show “-----” and the volume display will show the current value of the unit price.

**Example:**

Enter the new unit price with at least three digits for three money display digits to be shown after the decimal point.\* For example, to set the new unit price to \$1.50, enter 1500. Enter 1509 for \$1.509 price.

Press # key. The volume display will show the unit price with the correct number of digits after the decimal point. Again, for the example above, the volume display will show 1.500.

Press NEXT to input the next unit price, and repeat above steps. Continue until all the unit prices are input and Save the unit prices as per the following procedure: Note that while inputting the unit prices, the unit price display continues to show the sub-function and not the unit price itself.

**TABLE 2-1 Hose Positions Defined by Values of *N*.**

| DISPENSER TYPE | N=7          | N=6          | N=5    | N=4          | N=3          | N=2          | N=1          |
|----------------|--------------|--------------|--------|--------------|--------------|--------------|--------------|
| 3/V595 (4+1)   |              | Lo Feedstock | Lo-BL  | Hi-BL        | HI Feedstock |              | Single Grade |
| 3/V595 (3+1)   |              | Lo Feedstock | BL     | HI Feedstock |              |              | Single Grade |
| 3/V595/U       | Lo Feedstock | Lo-BL        | Mid-BL | Hi-BL        | HI Feedstock |              |              |
| 3/V595/U (4)   | Lo Feedstock | Lo-BL        | Hi-BL  | HI Feedstock |              |              |              |
| 3/V580         | Lo Feedstock |              | BL     |              | HI Feedstock |              |              |
| 3/V585         | Lo Feedstock | Lo-BL        | Mid-BL | Hi-BL        | HI Feedstock |              |              |
| 3/V590         |              |              |        | HI Feedstock | BL           | Lo Feedstock |              |
| 3/V590/U       | Lo Feedstock |              | BL     |              | HI Feedstock |              |              |
| 3/V591         | Lo Feedstock |              | BL     |              | HI Feedstock |              | Single Grade |
| 3/V490/U       |              |              |        | AA           | Z            | Y            | X            |
| 3/V490         |              |              |        | AA           | Z            | Y            | X            |
| 3/V390         |              |              |        |              | Z            | Y            | X            |
| 3/V399         |              |              |        |              |              | Y            | X            |
| 3/V389         |              |              |        |              |              | Y            | X            |
| 3/V387         |              |              |        |              |              |              | X            |

\* This is the default mode. The number of digits after the decimal points is set in function F14.02.

## 2.4. SETTING BLEND RATIOS

Function **F18** is accessed to set the blend ratios, using the remote control interface. The sub-function **F18.1N**, where *N* is the logical nozzle number, is used to set the blend ratios for side 1 and the sub-function **F18.2N** is used to set the blend ratios for side 2. Active values of *N* are given in Table 2-1.

### To access and set the Blend Ratios for Side 1

1. Press **ENTER**  
*PASS 1* (enter password)
2. Press **ENTER**
3. *PASS 2* (enter password)
4. Press **ENTER**. The unit price display will show *F—* (dashes means enter numbers to proceed).
5. Enter **18** to access *F18*
6. Press **ENTER**. The unit price display will show *F18*. (meaning the function has been accessed).
7. Press **ENTER** to access the sub-functions of *F18*. The unit price display shows *18.11* (here *N=1*).

The volume display will indicate the value of the blend ratio corresponding to logical nozzle #1(*N=1*). If there is no data for this logical nozzle, the number “**101**” will be displayed. This applies to all logical nozzles. To access the blend ratio for the next logical nozzle, press **NEXT**. The unit price display will show *18.12* and the volume display will show whatever the value of the blend ratio is for logical nozzle #2. Subsequent pressing of **NEXT** will advance the unit price display to *18.17*, the last logical nozzle. Pressing **NEXT** again will advance the unit price display to *18.21*, The “2” in “*18.21*” indicates Side 2 and the “1”, logical nozzle #1. The volume display will show the blend ratio assigned to *logical nozzle #1 of Side 2*.

8. Enter the blend ratio by using **UP** and **DOWN** keys or by press the # key and enter the blend ratio, followed by **ENTER**. For example, to change the value of the blend ratio from 101 to 89, press the **DOWN** button until **89** shows up on the price display, then press **ENTER**, or type in #89, **ENTER**.
9. Continue until all the blend ratios are entered for Side 1 and Side 2 and save the settings as follows:
10. Press **ENTER**. The price display will show “-----“, the volume display will be blank and the unit price display will show the last sub-function accessed.
11. Press **00** (to access *F00*)
12. Press **ENTER**. The unit price should now display *F00*, the price display will show “-----“ and the volume display will be blank.
13. Press **ENTER** and the volume display will show a *1*.
14. Press **UP** twice to change the value in the volume display from *1* to *3*.
15. Press **ENTER**. The volume display should show a *3*.
16. Press **ENTER**. *CHANGE STORED* should appear on the display momentarily. The display should return to normal in a few seconds. When it does, the unit price displays should show the new prices. If they do not show the desired unit prices, access the appropriate sub-function to make sure that the unit price data is correct.

## 2.5. SETTING THE FUELING POINT ID

The procedure below is used to set the dispenser fueling point address. The dispenser FPID should be input and saved before control is transferred to the POS system.

Functions **F05** and **F06** are accessed to set the FPID on Side 1 and Side 2, respectively. To set the FPID, the desired FPID must be input and saved.

To access and set the FPID for Side 1:

1. Press **ENTER**  
*PASS 1* (enter password)
2. Press **ENTER**  
*PASS 2* (enter password)
3. Press **ENTER**. The unit price display will show *F—* (dashes means enter numbers to proceed)
4. Press **05** to access *F05*
5. Press **ENTER**. The unit price display will show *F05* indicating the function has been accessed. The volume display will show the current FPID or “**0**” when no FPID has been assigned to that side.
6. Input the desired FPID by using the **UP** and **DOWN** keys followed by **ENTER**, or by pressing the **#** key followed by the value of the FPID followed by **ENTER**.
7. Press **ENTER** and enter **00** to access function *F00* to save the changes.
8. Change the 1 to a **3** with the **UP** key (or enter 3) to save changes and press the **ENTER** key. The volume display will show the 3.
9. Press **ENTER**. The display will show *CHANGE STORED* momentarily and then return to normal in a few seconds and the unit price displays will show the new prices. If they do not show the desired unit prices, access the appropriate sub-function to verify the unit price data.
10. Repeat the procedure for Side 2.

## 2.6. AUTHORIZING THE DISPENSER

The dispenser must be authorized before it will dispense product.

In stand-alone operation, not connected to a control system, the dispenser is always authorized, unless the dispenser is equipped with the (optional) Authorize key switch on the bezel. This momentary contact key switch can be used for one time authorizations.

When connected to a control system, the system programming determines authorization.



### **3. ELECTRONIC PARTS**

The electronics package in 3 /Vista dispensers features a high performance 16 bit pump computer, flash RAM memory and infrared **IR remote control programming** and diagnostics. The IR remote is used to program computer **functions** such as filling mode, prices, blend ratios, and fueling point number. The remote also is used to view the diagnostic **statistics** such as, error codes, event counters, flow rates and calibration factors, to name just a few. See Section 6 for a detailed discussion on IR remote programming of the computer.

An important troubleshooting component on the computer board is the on-board **LED indicators**. In addition to voltage source indicators, the LEDs provide a visual indication of data link, pulser and data bus communications. See Section 9 for location and description of the LEDs.

Another service tool is the **Service Terminal Kit**. Software and hardware included in the kit will allow technicians to interface the pump computer via a laptop computer to perform troubleshooting and other diagnostic procedures. Pump software revision changes and model template configurations are performed by uploading software from the laptop to the pump computer via an RS-232 link. Procedures for using the Service Terminal Kit are given in Section 8.

The electronic boards, as well as the Service Terminal Kit and the IR remote control, are shown in the spare parts list below. Board layouts and connector pinouts are shown in Section 9.

#### **3.1. ELECTRONIC SPARE PARTS LIST**

- 3/Vista (iGEM) Computer Board
- 3 Product Display Board
- 5 Product Display Board
- 24Volt DC Distribution Board
- 24Volt Electro-Mech Totalizer
- 24Volt Power Supply Assy
- Pump Relay Board
- Intelligent Pulser
- Intrinsic Safe Barrier Assy
- Dual Wayne Vac Control Board
- Dual CAT Controller Board





## **4. MECHANICAL PARTS**

### **4.1. LIFT-TO-START NOZZLE BOOT**

The nozzle boot switch assembly (see section 10) consists of a proximity reed switch attached to the rear of the nozzle boot casting. A magnet is contained in the Lift-to-Start lever and when the lever is lifted to the ON position the magnet is brought into alignment with the proximity switch, turning the switch ON. There is no adjustment for the switch.

Check the operation of the nozzle switch as follows:

1. Authorize the dispenser and remove the nozzle from the nozzle boot. Lift the nozzle hook lever fully upward to make sure the switch turns ON. An ON switch will be indicated by the unit price displays of the unselected products going OFF or displaying dashes.
2. Lower the Lift-to-Start lever to the down position and check that the switch turns OFF. An OFF switch is indicated by the unit price displays of the unselected products coming back ON.

### **4.2. PUSH-TO-START NOZZLE BOOT**

The nozzle boot switch assembly (see section 10)) consists of a proximity reed switch attached to the side of the nozzle boot casting and a magnetic actuator shaft inserted into a spring-loaded flipper within the nozzle boot. When the nozzle is removed, the flipper rotates and aligns the magnetic shaft with the proximity switch, turning the switch ON. There is no adjustment for the switch.

Check the operation of the nozzle switch as follows:

1. Authorize the dispenser and remove the nozzle from the nozzle boot to make sure the switch turns ON. An ON switch will be indicated by the lighted Push-to-Start buttons and the unit price displays blinking.
2. Insert nozzle slowly into the nozzle boot and check that the switch turns OFF. An OFF switch is indicated by the lighted Push-to-Start buttons turning OFF and the unit price displays stop blinking.



## **5. HYDRAULIC PARTS**

The four basic hydraulic parts in the dispenser are discussed in detail in this section. These parts are as follows:

- Strainer and Filter
- Proportional Flow Control Valve
- iMeter
- Check & Pressure Relief Valve

### **5.1. STRAINER AND FILTER**

The strainer and filter (see Figure 5-1) are mentioned in this document because they may cause the dispenser to deliver slowly. In some cases this may appear to be a service problem. In reality the filter should be changed and the strainer cleaned on a regular basis.

Before removing the strainer or filter assembly, trip the impact valve and turn OFF the circuit breaker for the associated submersible pump.

#### **5.1.1. Strainer**

If the underground installation is new, it may be necessary to clean the strainer screen two or three times the first few days of operation to remove debris and pipe dope. After this, occasional cleaning of the strainer is all that should be required. The fuel filter should be changed whenever the strainer is cleaned.

The strainer is located above, and held in place by, the filter. After removing the filter, again place suitable container below filter/strainer casting to catch product and sediment, gently pull the strainer downward to remove it from the filter/strainer casting. Replace or clean strainer screen of any debris and re-install.

#### **5.1.2. Filter**

Like the strainer, in new installations it may be necessary to change the filter frequently in the first few days of operation in order to ensure proper operation.

The fuel filter is removed the same way an oil filter is removed from a car engine. Place a container under the filter to catch the fuel. To install the new filter, first apply a film of oil to the gasket and hand turn until the gasket contacts the base. Then tighten one half turn. Open the emergency shear valve, turn the submersible circuit breaker ON and check for leaks.

5.1. STRAINER AND FILTER , continued

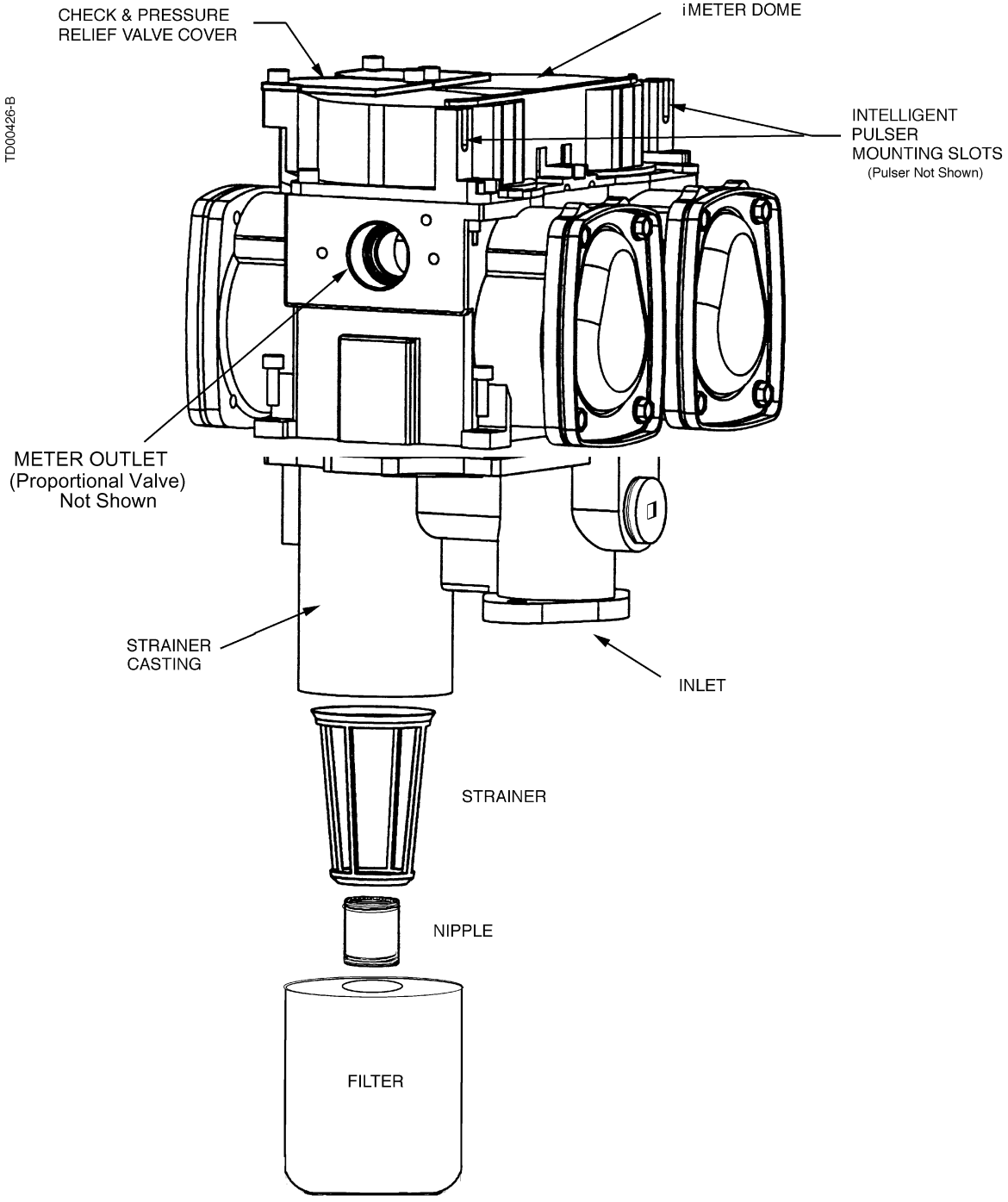

**FIGURE 5-1. STRAINER AND FILTER.** *The strainer should be cleaned as needed to remove any debris it has captured. The filter should be UL recognized.*

## 5.2. PROPORTIONAL FLOW CONTROL VALVE

The proportional flow control valve (see Figure 5-2) is a pilot-operated, diaphragm solenoid valve. It has three main functions in the dispenser:

- Positive shutoff
- Blend ratio control
- Flow rate regulation

Located between the meter and the hose outlet, the valve is controlled by a 24 VDC pulse width modulated signal. Normally closed, the pilot opens by an amount proportional to the amount of current sent to the valve coil. As the pilot raises off its seat, it reduces the pressure to the back side of the diaphragm causing it to lift off of its seat as well. The same applies to the valve closing; the diaphragm follows the pilot back to the closed position as the current to the coil is reduced for blender models. The computer continually adjusts the current to the valves during a sale based on the desired blend ratio of the two feedstocks and maximum allowable flow rate. The high and low products remain separate until they are mixed at the hose outlet in proportional blenders or at the outlet valve in fixed ratio blenders.

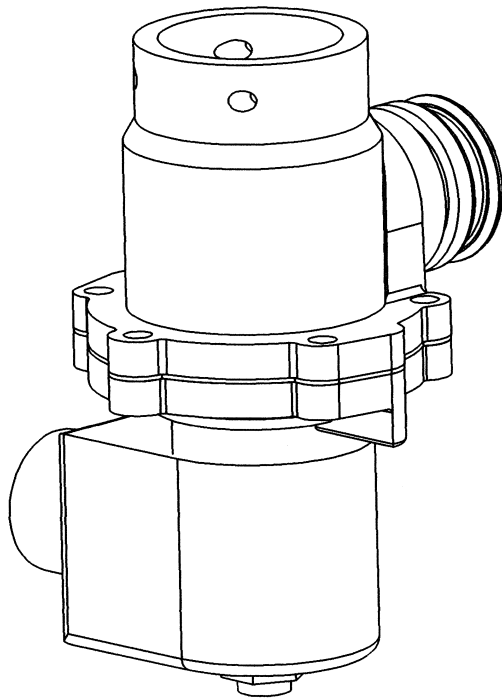

**FIGURE 5-2. PROPORTIONAL FLOW CONTROL VALVE.** *In 3/Vista models the valve is located at the iMeter outlet.*

## 5.2 PROPORTIONAL FLOW CONTROL VALVE, continued

The pilot operated proportional solenoid valve performs three basic functions in the dispenser. It provides positive shutoff, regulates the ratio of blended feedstocks, and controls the flow rate through the hydraulic path by limiting the maximum flow rate through a given hose.

The pilot operated proportional flow control valve consists of two main parts:

- The proportional valve
- The valve coil

The proportional valve is an electrically operated solenoid made up of a body and an operator. It controls all flow through the dispenser.

The valve coil controls the operator of the valve. The coil is energized with a pulse width modulated (PWM) signal that sends discrete bursts of current at a set frequency level. When the coil receives this signal, the pilot inside the operator reacts to the changing magnetic field and moves up and down depending on the amount of current through the coil. The position of the pilot relative to the pilot orifice in the diaphragm controls the amount of flow.

In all Wayne dispensers using this valve, the general order of operation is the same. At the beginning of a sale, the coil is energized with a minimum current level, allowing slow product flow to start. After a small amount of product is delivered, the coil is energized with more current to initiate full regulated flow. For preset sales, the dispenser will switch back to slow flow at a pre-determined point.

### 5.2.1. No Flow - Flow Control Valve Off

Flow control valve “Off” or no flow occurs when the inlet to the valve is charged. But there is no flow required from the particular valve as in the instance where a submersible pump motor is running because another fueling point is being used. The pilot stays closed allowing pump pressure to build on the back side of the diaphragm, closing the outlet port.

### 5.2.2. Slow Flow - Flow Control Valve On

Flow control valve “On” slow flow occurs at the beginning of all sales, and again at the end of preset sales. In this case the coil is energized with current bursts of shorter duration. This allows the pilot to slightly move off its seat, allowing slow flow through the pilot orifice leading to the valve outlet, but not relieving enough pressure to cause the diaphragm to open.

### **5.2.3. Full Regulated Flow - Flow Control Valve On**

Flow control valve “On” full regulated flow occurs during the main portion of all sales. At this time, the coil is energized with bursts of current of longer duration, pulling the pilot further off its seat, relieving the pressure balance, and allowing the diaphragm to open by an amount relative to the distance between pilot and the pilot orifice. The position of the pilot is constantly moving in very small increments based on the signals sent from the computer relative to controlling a specific blend ratio and/or maintaining a maximum flow rate of 10 GPM through a hose. As the computer senses the need to increase or decrease the amount of a particular feedstock, it will send signals to the coil of longer (to open) or shorter (to close) duration. As a result, the pilot moves up or down causing the diaphragm to follow its movement and achieve the proper amount of flow.

When the delivery is complete, the coil is de-energized, allowing the pilot to return to its closed position. This allows pressure to build on the back side of the diaphragm, forcing it to close and seal the outlet port thereby stopping flow.

## **5.3. iMETER**

The iMeter is designed and assembled around a modular type concept using fewer parts and allowing easier access for service. The iMeter module Figure 5-3. contains two meters in one assembly and the Intelligent Pulser. Each of the two meters in the iMeter module is a positive displacement meter. In remote dispensers, the bottom of the iMeter body is attached to the filter/strainer casting as shown in Figure 5-1. In suction pumps, the bottom of the iMeter body is attached to the top cover of the compact pumping unit. There are no external moving parts on the iMeter. Calibration is accomplished electronically. iMeter calibration, Intelligent Pulser operation and proper replacement procedures are covered in Section 10.

### **5.3.1. Check and Pressure Relief Valve**

There are two Check & Pressure Relief (C&PR) valves located atop the iMeter module under removable covers, as shown in Figure 5-3. The top mounted location allows for check valve replacement without draining the meter body. Once a delivery is complete and the diaphragm valve is closed, the product pressure between the check valve and the nozzle will be held at the pressure of the last delivery. If the pressure should build up due to temperature rise in the hose or a car runs over the hose, the relief function of the C&PR valve would relieve the pressure buildup. The relief valve is set to relieve pressure between 30-50 psi.

5.3. iMETER , continued

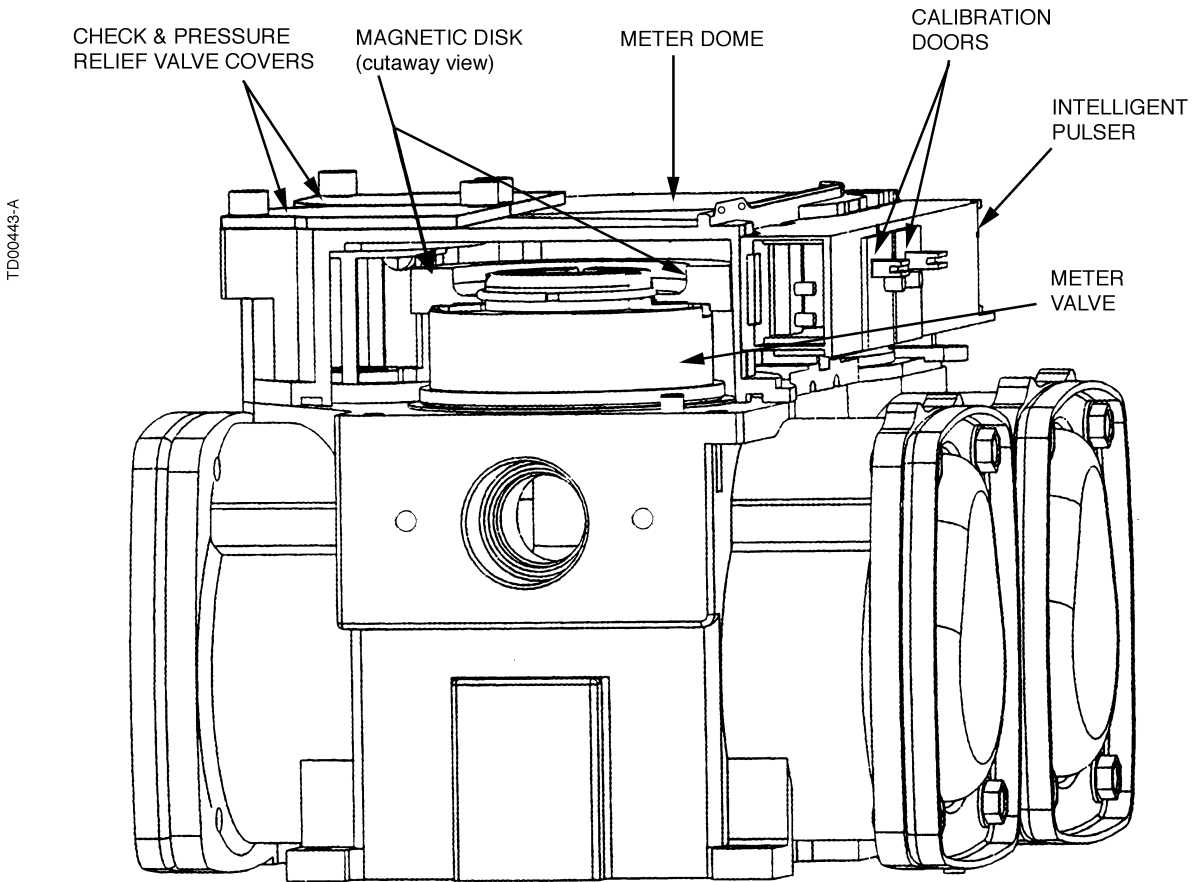

**FIGURE 5-3. iMETER CUTAWAY.** *The magnetic disk affixed to the top of the meter valve is rotated by the meter crank shaft. As the disk rotates, the pulser converts the changing magnetic field into digital pulses.*



#### 5.4. DOUBLE BUMP TUBING

On 3/Vista dispensers, **double bump** product tubing is used between the iMeter outlet, proportional valve, and hose outlet casting. The double bump connection eliminates the need to torque the compression fittings that were used on the flare tubing.

As shown in Figure 5-4, the o-ring fills the space between the two bumps, hence the name double bump, and when the tube is inserted into the mating connection, the o-ring compresses or spreads across this space, making a tight seal around the cylinder. The Safety Clip, while securing the connections, also improves the seal by allowing some flexibility as to exactly where the seal is made. An assembled view is shown in Figure 5-5.

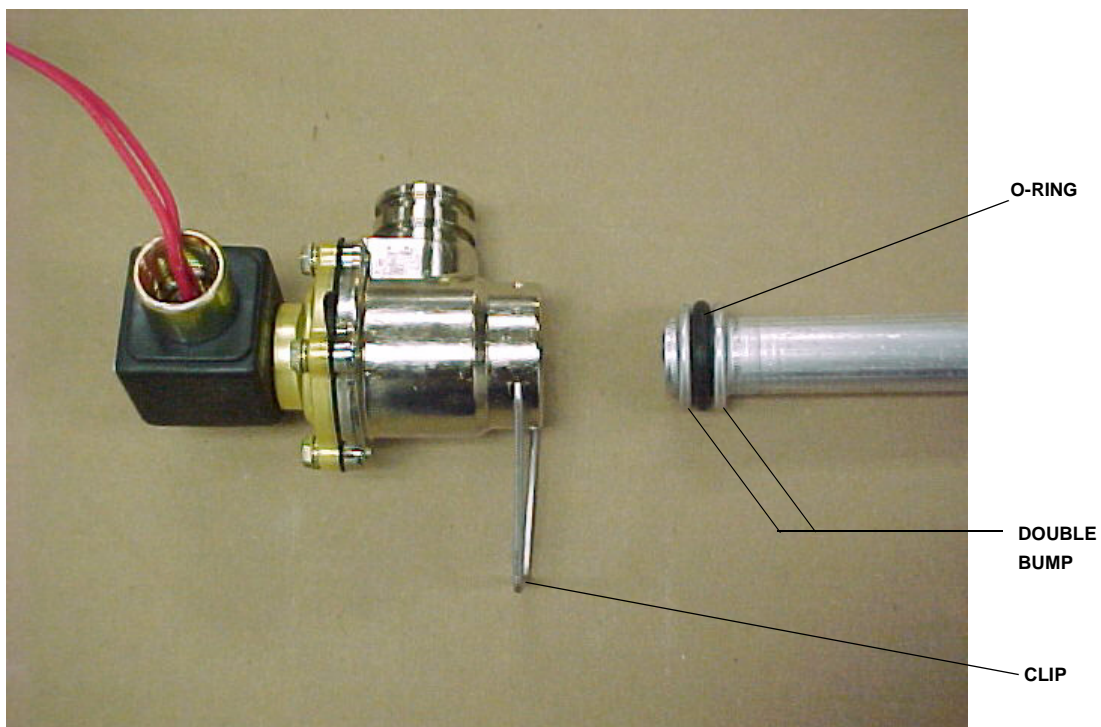

**FIGURE 5-4. DOUBLE BUMP TUBE BETWEEN VALVE AND HOSE OUTLET.** *Valve conduit not shown.*

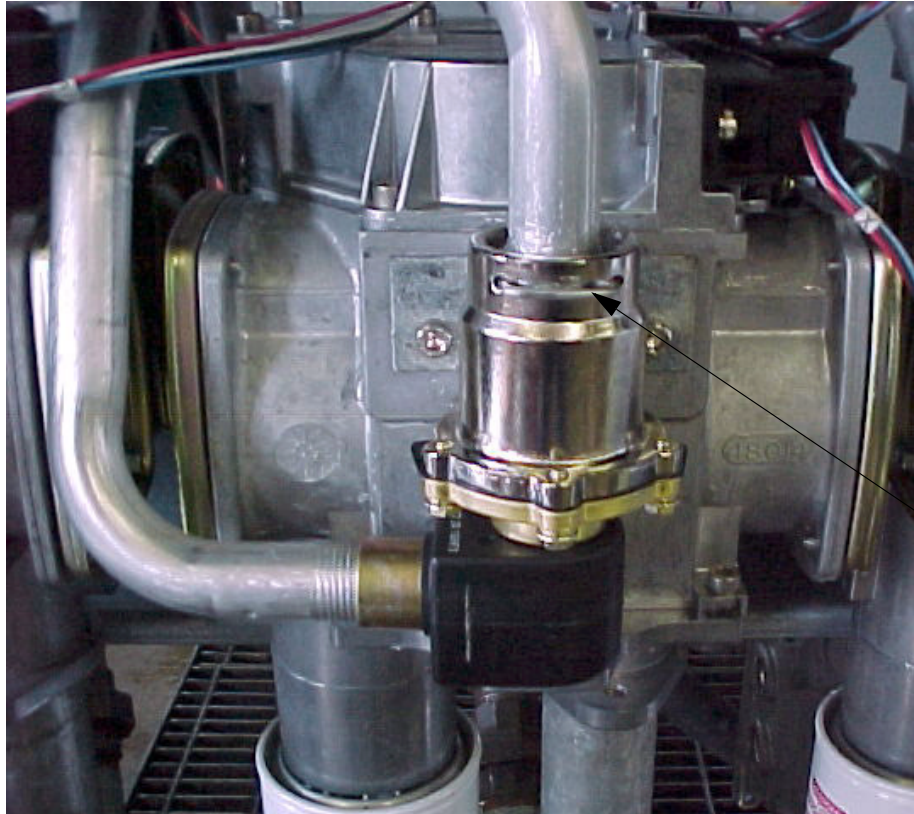

**FIGURE 5-5. DOUBLE BUMP TUBE ASSEMBLED TO VALVE.** *In 3/Vista dispensers, the proportional valve is located at the iMeter outputs.*

## 6. PROGRAMMING FUNCTIONS AND STATISTICS

The Maintenance Mode is used to access the functions and statistics in the 3/Vista computer. Service technicians can access the Maintenance Mode by using the Infrared Remote (IR) remote control or, as explained in Sec. 8, by running the Service Terminal Program (STP) from a laptop computer. The IR remote and the descriptions of functions and statistics are discussed in detail in this section.

### 6.1 ENTERING MAINTENANCE MODE VIA IR REMOTE CONTROL

The Infrared Remote (IR) Control communicates with the pump computer by an infrared link to the sensor mounted on the dispenser's sales display board behind the bezel.

The IR remote control has 16 buttons. When the remote control is held close to the infrared eye (Figure 6-1.) on the display board, it can be used to access dispenser functions and statistics (diagnostics). The remote is used to set unit prices, fueling point numbers, serial or stand-alone communications, blend ratios, read electronic totalizers and error codes, and perform many other diagnostic and service related tasks via the Maintenance Mode.



Four levels of entry to the Maintenance Mode are listed below. To access the mode, hold the remote control approximately 18 inches from the display and press the appropriate key as follows:

|  |       |
|--|-------|
| for Field Service entry using field engineer password press    | ENTER |
| for Station Manager entry using station manager password press | 1     |
| for Operator entry using operator password press               | 2     |
| for Weights and Measures entry using W&M password press        | CLEAR |

The maintenance mode asks for a password twice before allowing access to the maintenance mode functions and statistics. A 10 second time-out is built into the password entry code. When the word *PASS 1* appears on the sales display, **enter password** and press **ENTER**. You have 10 seconds to start entering the password. The timer restarts after you press a key. *PASS 2* appears on the sales display, prompting you to **enter the same password again** and press **ENTER**. The unit price display will show "F - - ", the money display shows the software version number, and the volume display shows the date of the software version. At this point, you can go to either Functions or to Statistics. To edit or view functions, **enter the function number** and press **ENTER**. The function number will appear in the unit price display. To enter the statistics viewing mode press either the **UP** or **DOWN** arrow when the unit price is displaying "F - - ". When you enter the statistics viewing mode, the unit price display window shows "S - - ", the money display window shows the current transaction count for side A, and the volume display window shows the current transaction count for side B. To view specific statistics, **enter the statistic number** and press **ENTER**. The statistic number appears in the unit price display. Note that side A is side 1 (the junction box side) and side B is side 2.

## 6.1 ENTERING MAINTENANCE MODE VIA IR REMOTE CONTROL, continued

When you enter the sub entry level, the unit price display shows the function/statistic number in the two left-most digits and the sub level number in the two right-most digits separated with a decimal point. The *F* or *S* no longer appear. The *NEXT* key advances the display to next sub-function or sub-statistic within the current function or statistic, however, the *UP/DOWN* key advances to next function or statistic when *F* or *S* is still showing in the display window. When " - - - - " dashes are showing in the money display, the function is waiting for numeric data entry, such as unit price, etc. Press the *#* key prior to entering numeric data.

If you enter numeric data without first pressing the *#* key, the system goes to the sub-function or sub-statistic of the corresponding number that you entered. If the number is beyond the range of available sub-functions or sub-statistics, the maximum sub function or sub-statistic is used.

In summary, the maintenance mode is entered by performing the short procedure below:

```
hold the IR remote close to the display and
press ENTER
enter password _ _ _ _
press ENTER
enter password again _ _ _ _
press ENTER
enter function number
```

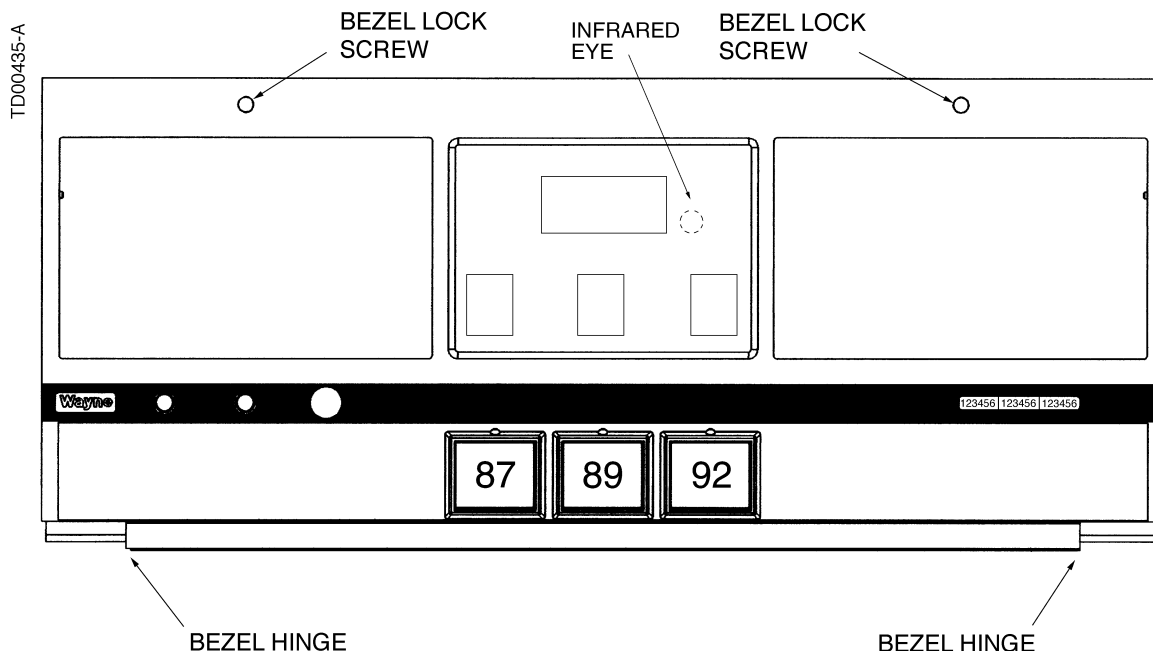

**FIGURE 6-1. INFRARED INTERFACE LOCATION.** The dispenser infrared eye is located behind the sales display on each side of the dispenser. Hold the IR remote close to the eye.

## 6.2 FUNCTION PROGRAMMING

This section gives the definitions of the programming functions that can be accessed via the Maintenance Mode. The functions are used to set filling mode, fueling point numbers, unit prices, blend ratios and, if required, to set calibration factors and flow rates. The dispenser template controls access to functions and sub-functions. The template contains an access level table that determines what functions each user has access to. Access levels are: Read and Write, Read Only and No Access.

### F00 Exit Function

Use this function to select one of three maintenance mode exits. Sub-function numbers are in the format .0X where X = is defined as follows:

- .00 Exit Option, 1 through 3
  - 1 = Do not exit and do not save changes
  - 2 = Exit, but do not save changes
  - 3 = Exit and save changes

### F01 Filling Modes

Sub-function numbers are in the format .0X where X = the selected configuration parameters defined as follows:

- .00 Filling Mode 1 through 4
  - 1 = Serial Mode, dispenser controlled by site controller via serial link.
  - 2 = Stand Alone Mode, dispenser not supervised by a site controller.
  - 3 = Serial W&M Mode, same as #1 but vol decimal point format forced to .xxx vol units.
  - 4 = Stand Alone W&M Mode, same as #2 but vol decimal point format forced to .xxx vol units.

### F02 Clock Configuration

The system does not update automatically for Daylight Savings Time. Sub-function numbers are in the format .0X where X = the selected configuration parameters defined as follows:

- .00 Time in the format HH.MM
- .01 Date in the format MM.DD
- .02 Year in the format YY.YY

### F03 Set Side A Unit Prices

Data values entered in this function do not become part of the template data. Sub-function numbers are in the format:

- .0N Set credit prices
- .1N Set cash prices
  - N Logical nozzle number 1-8

### F04 Set Side B Unit Prices

Data values entered in this function do not become part of the template data. Sub-function numbers are in the format:

Sub-function numbers are in the format:

- .0N Set credit prices
- .1N Set cash prices
  - N Logical nozzle number 1-8

#### **F05 Set Side A Fueling Point Address**

.00 Fueling Point Address, 0 through 98, where 0 = none Assigned

#### **F06 Set Side B Fueling Point Address**

.00 Fueling Point Address, 0 through 98, where 0 = none Assigned

#### **F07 Dispenser Configuration**

Sub-function numbers are in the format .0X where X = the selected configuration parameters defined as follows:

- .00 Maximum logical nozzle number for each side, 1-8
- .01 Dispenser geometry, 1 = single sided 2 = double sided
- .02 Maximum blend error allowed, 1-5 (units of %)
- .03 First check set for blending if liters, 2-200 (units of 1/10 Liters)
- .04 First check set for blending if gallons, 5-50 (units of 1/10 Gallons)
- .05 Not Used
- .06 Manufacturing default for Intelligent Pulser
- .07 Stop button configuration, 1 = stop both sides 2 = stop side

#### **F08 Side A Dispenser Type Configuration Part #1**

Sub-function numbers are in the format .XN where X = the selected configuration parameters and N = the logical nozzle number 1-8 as follows:

- .0N Physical nozzle number assignment, 0-8, 0 = none assigned
- .1N Product type assignment, 1 = non-blend, 2 = blend
- .2N Unit Price display assignment, 0-8, 0 = none assigned
- .3N Primary meter number assignment, 0-8, 0 = none assigned
- .4N Secondary meter number assignment, 0-8, 0 = none assigned
- .5N Primary valve number assignment 0-8, 0 = none assigned
- .6N Primary valve type, 1-3, 1 = On/Off 2 = Fast/Slow 3 = Proportional
- .7N Secondary valve number assignment, 0-8, 0 = none assigned
- .8N Secondary valve type, 1-3, 1 = On/Off 2 = Fast/Slow 3 = Proportional

#### **F09 Side B Dispenser Type Configuration Part #1**

Sub-function numbers are in the format .XN where X = the selected configuration parameters and N = the logical nozzle number 1-8 as follows:

- .0N Physical nozzle number assignment, 0-8, 0 = none assigned
- .1N Product type assignment, 1 = non-blend, 2 = blend
- .2N Unit Price display assignment, 0-8, 0 = none assigned
- .3N Primary meter number assignment, 0-8, 0 = none assigned
- .4N Secondary meter number assignment, 0-8, 0 = none assigned
- .5N Primary valve number assignment 0-8, 0 = none assigned
- .6N Primary valve type, 1-3, 1 = On/Off 2 = Fast/Slow 3 = Proportional
- .7N Secondary valve number assignment, 0-8, 0 = none assigned
- .8N Secondary valve type, 1-3, 1 = On/Off 2 = Fast/Slow 3 = Proportional

## **F10 Side A Dispenser type Configuration Part #2**

Sub-function numbers are in the format .XN where X = the selected configuration parameters and N = the logical nozzle number 1-8.

- .0N Octane number assignment, 00-99, 00 = none assigned
- .1N Product select button input number assignment, 0-8, 0 = none assigned
- .2N Push-to-Start button input number assignment, 0-8, 0 = none assigned
- .3N Reserved for manufacturer's use with vapor recovery system
- .4N Beep annunciator in a series of six beeps on physical nozzle lift, 1 = Yes, 2 = No

## **F11 Side B Dispenser Type Configuration Part #2**

Sub-function numbers are in the format .XN where X = the selected configuration parameters and N = the logical nozzle number 1-8.

- .0N Octane number assignment, 00-99, 00 = none assigned
- .1N Product select button input number assignment, 0-8, 0 = none assigned
- .2N Push-to-Start button input number assignment, 0-8, 0 = none assigned
- .3N Reserved for manufacturer's use with vapor recovery system
- .4N Beep annunciator in a series of six beeps on physical nozzle lift, 1 = Yes, 2 = No

## **F12 Side A Pump Assignments**

This function is for the submersible pump relays. Sub-function numbers are in the format .XN where X = the selected configuration parameters and N = the logical nozzle number 1-8.

- .0N Primary pump assignment, 0-8, 0 = none assigned
- .1N Secondary pump assignment, 0-8, 0 = none assigned

## **F13 Side B Pump Assignments**

This function is for the submersible pump relays. Sub-function numbers are in the format .XN where X = the selected configuration parameters and N = the logical nozzle number 1-8.

- .0N Primary pump assignment, 0-8, 0 = none assigned
- .1N Secondary pump assignment, 0-8, 0 = none assigned

## **F14 Dispenser Display Configuration**

Sub-function numbers are in the format .0X where X = the selected configuration parameters defined as follows:

- .00 Number of unit price displays per side, 0-8, 0 = none supported
- .01 Display mode after sale paid
  - 1 = Money is actual, volume is actual, unit price is actual
  - 2 = Money is zeros, volume is zeros, unit price is actual
  - 3 = Money is zeros, volume is zeros, unit price is blanks
  - 4 = Money and Volume actual, Unit Price blank
- .02 Money display digits right of decimal point, 0-4
- .03 Volume display digits right of decimal point, 0-4
- .04 Unit Price display digits right of decimal point, 0-4
- .05 Flash selected unit price display after 8s blanks 0s. 1 = No 2 = flash until flow 3 = flash always
- .06 Suppress display of leading zeros in normal mode, 1 = Yes 2 = No
- .07 Totals and Totalizers Amount display digits right of the decimal point, 0-4
- .08 Totals and Totalizers Volume display digits right of the decimal point, 0-4

## **F15 Dispenser Annunciator Configuration**

Sub-function numbers are in the format .0X where X = the selected configuration parameters defined as follows:

- .00** Beep annunciator on any button push  
1 = Yes 2 = No
- .01** Beep annunciator on physical nozzle lift  
1 = Yes 2 = No
- .02** Repeat annunciator beep if physical nozzle is out and Push-to-start or grade select is not satisfied  
1 = Yes 2 = No
- .03** Beep annunciator once for each eights, blanks, and zeros  
1 = Yes 2 = No

## **F16 Pulsar Configuration**

Sub-function numbers are in the format .0X where X = the selected configuration parameters defined as follows:

- .00** Measurement mode  
1 = Liters  
2 = Gallons  
3 = Imperial Gallons
- .01** Pulsar reverse pulse hysteresis, 1-64
- .02** Reverse pulse Limit (after hysteresis) on an in-use pulser, 1-99
- .03** Reverse pulse Limit (after hysteresis) on an idle/unused pulser, 1-255

## **F17 Dispenser Limits Configuration**

Sub-function numbers are in the format .0X where X = the selected configuration parameters defined as follows:

- .00** Maximum number of pulse errors on an in-use pulser (in a transaction), 1-99
- .01** Maximum number of pulse errors on an idle/unused pulser, 1-99
- .02** Maximum number of display errors/filling, 0-99, where 0 = disabled
- .03** Stop for “no flow” or “flow lost” time limit (0 - 1000 seconds)
- .04** Maximum number of consecutive no flow events w/out error, 0-10, 0 = disabled
- .05** Maximum number of flow lost events w/out error, 0-10, 0 = disabled
- .06** Maximum number of unfinished fillings, 0-10, 0 = disabled
- .07** Maximum filling amount/filling, 1-6 digits
- .08** Maximum volume amount/filling, 1-6 digits

## **F18 Blend Ratio Configuration**

Sub-function numbers are in the format: SN where S = the Side number (1=A, 2=B) and N = the logical nozzle number 1-8.

**SN** Blend ratio (data range is 0-101, in percent of Hi Feedstock. 101 = disabled (for a non-blend)



## F19 Volume Unit Specific Configuration

Sub-function numbers in the format .VX where V= volume unit selection (1= liters, 2=gallons) and X = the selected parameter defined as follows.

- .10 Suppressed volume @ start of filling, 1-9 cl.
- .11 Maximum volume for selection of new product, 1-9 cl.
- .12 Suppress overflow of preset limit, 0-99 cl.
- .13 Preset/Prepay slow down volume delta. 5-399 cl.
- .14 Forward pulse limit on idle/unused pulser. 1-99 cl.
- .20 Suppressed volume @ start of filling, 1-99 (units of 1/1000 Gallons)
- .21 Maximum volume for selection of new product, 1-99 (units of 1/1000 Gallons)
- .22 Suppress overflow of preset limit, 0-99 (units of 1/1000 Gallons)
- .23 Preset/Prepay slow down volume delta. 2-999 (units of 1/1000 Gallons)
- .24 Forward pulse limit on idle/unused pulser. 1-999 (units of 1/1000 Gallons)

## F20 Dispenser Serial Link Configuration

Sub-function numbers are in the format .0X where X = the selected parameter defined as follows:

- .00 Protocol
  - 0 = Off link
  - 1 = RS485 Standard DART
  - 2 = RS485 Full DART
  - 3 = LON
  - 4 = U.S. Current Loop**
  - 5 = Ljungman Current Loop
  - 6 = Ferranti
- .01 Baud rate
  - 1 = 4800
  - 2 = 9600
  - 3 = 19200
  - 4 = 38400
- .02 CRC Calculation 1 = Enable, 2 = Disable
- .03 Send "Filling Complete" after zero sale. 1 = Yes, 2 = No
- .04 Serial Link Control of the Dispenser Light Enable. 1 = Yes, 2 = No

## **F21 Miscellaneous Configuration**

Sub-function numbers are in the format .0X where X = the selected parameter defined as follows:

- .00 Pump Motor ON configuration**
  - 1 = ON at end of display test
  - 2 = ON at start of display test
  - 3 = ON at product selection
- .01 Lock on filling mode configuration**
  - 1 = Access to filling mode configuration restricted
  - 2 = Access allowed.
- .02 Standalone indication enabled (show four digits right of decimal point)**
  - 1 = Yes
  - 2 = No
- .03 Blank or dash un-selected unit price displays on product selection**
  - 1 = Blank
  - 2 = Dash
- .04 Product change allowed after fuelling started**
  - 1 = product change allowed after fuelling started
  - 2 = product change not allowed after fuelling started
- .05 Electro-mechanical totalizer configuration**
  - 1 = Each side has it's own electro-mechanical totalizers per meter
  - 2 = One electro-mechanical totalizer per meter shared by both sides
- .06 Diagnostic Flow Rate Display**
  - 0 = Display sale amount
  - 1 = Display primary flow rate
  - 2 = Display secondary flow rate
  - 3 = Display primary and secondary flow rate

## **F22 Sales Amount Calculation**

Sub-function numbers are in the format .0X where X = the selected parameter defined as follows:

- .00 Denomination ratio between Money display and Unit Price display**
  - 1 = 1/1
  - 2 = 10/1
  - 3 = 100/1
  - 4 = 1/10
  - 5 = 1/100
- .01 Count by ones or fives in least significant digit of Money display**
  - 1 = Ones
  - 2 = Fives
- .02 Volume digits to the right of the decimal point used in amount calculation 0-5, where 5 = use volume decimal point as defined in function 18.5**
- .03 Money preset configuration. As the unit price increases, the system reaches a point when certain preset money amounts cannot be set due to the resolution of the metering system and/or the configured resolution of the volume used for the money calculation. Program this sub-function to give the desired result when this occurs.**
  - 0 = Calculate the closest volume from the money and the unit price and show the actual money amount at the end of the sale.
  - 1 = Calculate the closest volume from the money and the unit price but show the preset money amount at the end of sale as long as the sale hasn't reached the maximum overrun volume.
  - 2 = Calculate a volume amount that will ensure a money amount that is greater than or equal to the preset amount and show the preset money amount at the end of the sale as long as the sale hasn't reach the maximum overrun volume.

## F23 Miscellaneous Timers

Sub-function numbers are in the format .0X where X = the selected parameter defined as follows:

- .00 Display test time, total test time - also known as valve on delay, 2-24 units of 1/2 sec
- .01 Minimum time between fillings, 0-20 units of 1/2 sec, where 0 = disabled
- .02 Stop for offline error, 0-30 seconds, where 0 = disabled
- .03 Maximum time allowed for filling, 0-60 minutes, where 0 = disabled
- .04 Time from unit price change until next start of sale, 0-15 sec

**NOTE:** See Section 11 for a complete description of Functions 24 and 25 and local preset operation.

## F24 Local Preset Operating Configuration

Sub-function numbers are in the format .0X where X = the selected parameters defined as follows:

- .00 Preset Operation
  - 1 = Money only
  - 2 = Volume only
  - 3 = Default to money
  - 4 = Default to volume
- .01 Preset entry required before filling
  - 1 = preset required
  - 2 = preset not required
- .02 Fill mode display
  - 1 = display “-----” when fill key pressed
  - 2 = display “FILL” when fill key pressed
- .03 Preset mode display
  - 1 = Display “ ” on sale display during preset
  - 2 = Display “-----” on sale display during preset
  - 3 = Display “Preset” on sale display during preset
- .04 Preset entry timeout
  - 0-60 seconds, 0 = disabled
- .05 Preset entry operation
  - 0 = Accumulate preset key entries
  - 1 = Scroll preset key entries
- .06 First digit entry point for money
  - 1 through 6, digit 1 is the leftmost digit
- .07 First digit entry point for volume
  - 1 through 6, digit 1 is the leftmost digit
- .08 Sale display option
  - 0 = Use preset keypad display
  - 1 = Use sale display to indicate preset

## F25 Local Preset SoftKeys Configuration

Preset function has capacity to support 32 keys. Sub-function numbers are in the format .01 to .32, representing the softkeys which can contain any of the possible values below:

- 0 = Disabled
- 1 = select softkey value #1
- 2 = select softkey value #2
- 3 = select softkey value #3
- 4 = select softkey value #4
- 5 = select softkey value #5
- 6 = select softkey value #6
- 7 = select softkey value #7
- 8 = select softkey value #8
- 9 = select softkey value #9
- 10 = select softkey value #10
- 11 = select money
- 12 = select volume
- 13 = toggle
- 14 = select FILL
- 15 = clear key
- 16 = enter key

## **F26 VAP Configuration**

Sub-function numbers are in the format .0X where X = the selected configuration parameters defined as follows:

- .00 ORVR control
  - 1 = Enabled
  - 2 = Disabled

## **F27 Side A Dispenser Configuration**

- .00 Button input for Local Authorize function, 0-8, where 0 = not supported

## **F28 Side B Dispenser Configuration**

- .00 Button input for Local Authorize function, 0-8, where 0 = not supported

## **F29 Side A Liter Flow Rate Configuration**

- .0N Maximum slow flow rate, 3-50 (units of 1/10 Liters/min.)
- .1N Minimum slow flow rate, 0-50 (units of 1/10 Liters/min.), 0 = no minimum
- .2N Maximum fast flow rate, 10-180 (units of Liters/min.)
- .3N Minimum fast flow rate, 0-180 (units of Liters/min.), 0 = no minimum
- N Logical nozzle

## **F30 Side B Liter Flow Rate Configuration**

- .0N Maximum slow flow rate, 3-50 (units of 1/10 Liters/min.)
- .1N Minimum slow flow rate, 0-50 (units of 1/10 Liters/min.), 0 = no minimum
- .2N Maximum fast flow rate, 10-180 (units of Liters/min.)
- .3N Minimum fast flow rate, 0-180 (units of Liters/min.), 0 = no minimum
- N Logical nozzle

## **F31 Side A Gallon Flow Rate Configuration**

- .0N Maximum slow flow rate, 1-10 (units of 1/10 Gallons/min.)
- .1N Minimum slow flow rate, 0-10 (units of 1/10 Gallons/min.), 0 = no minimum
- .2N Maximum fast flow rate, 3-48 (units of Gallons/min.)
- .3N Minimum fast flow rate, 03-48 (units of Gallons/min.), 0 = no minimum
- N Logical nozzle

## **F32 Side B Gallon Flow Rate Configuration**

- .0N Maximum slow flow rate, 1-10 (units of 1/10 Gallons/min.)
- .1N Minimum slow flow rate, 0-10 (units of 1/10 Gallons/min.), 0 = no minimum
- .2N Maximum fast flow rate, 3-48 (units of Gallons/min.)
- .3N Minimum fast flow rate, 03-48 (units of Gallons/min.), 0 = no minimum
- N Logical nozzle

### F33 Password Change

Dashes appear in the money display window, and the word PASS appears on the volume display. When you begin editing, the money display goes blank and dashes appear instead of the regular entries. Enter the new password twice. The sub-function numbers are defined as follows:

- .00 Service Engineer Password, maximum of 6 characters (Use numbers only)
- .01 Station Manager Password, maximum of 6 characters (Use numbers only)
- .02 Station Operator Password, maximum of 6 characters (Use numbers only)
- .03 Weights and Measures Password, maximum of 6 characters (Use numbers only)

### F34 Diagnostics

These functions provide a way to test various parts of the hardware, including all switches, displays, beeper and Vapor recovery. Other motors and valves are not available for security and safety reasons. When a test is invoked, press **CLEAR** or **ENTER** to end the test.

- .01 **Switch test.** The money display shows 4 dashes until a switch is activated. A description of the activated switch and side (1 or 2) is displayed on the money display. For example, nozzle switch 3 on side 2 is displayed as 2n3 as long as the switch is depressed (N=nozzle, S=stop switch, B = bitbus, P = preset). When the nozzle is deactivated the display reverts to dashes.
- .02 **Display test.** A “walking segment” test is performed in which each segment of the display is turned on and off. Each digit of the display is tested at the same time.
- .03 **Vapor Recovery** subsystem test, Side A
- .04 **Vapor Recovery** subsystem test, Side B

These sub-functions simulate a flow rate to the vapor recovery system, which turns on the recovery motor accordingly. At least one nozzle on the specified side must have Wayne Vac enabled for the motor to turn on. The volume display shows the simulated flowrate. The money display shows actual RPM as measured by the computer. The **UP** key increases the simulated flowrate. The **DOWN** key decreases the flowrate.

Simulated flow rates:

Off

Low (7.0 GPM)

Medium (8.5 GPM)

High (10.0 GPM)

### F35 Side A Wayne Vac A/L Calibration Data

This function provides a way to calibrate the Wayne Vac A/L ratio.

There is an adder and a multiplier that can be used to change the ratio. The adder has more effect at the low flow rates (lower RPMs) and the multiplier has more effect at the higher flows (higher RPMs).

**.00** Default setting is 100, which is a 0 adder. To increase RPMs increase the number above 100. To decrease RPMs make the number lower than 100.

**.01** Default setting is 100, which is a 1 multiplier. To increase RPMs increase the number above 100. To decrease RPMs make the number lower than 100.

The example below shows how the adder and multiplier affect the motor speed.

Assume the speed is set at 1000 RPM, then:

| <b>F35.00</b> | <b>F35.01</b> | <b>Calculation</b>                 | <b>Result (RPM)</b> |
|---------------|---------------|------------------------------------|---------------------|
| 100           | 100           | $(1000+(F35.00-100))*(F35.01/100)$ | 1000                |
| 110           | 100           | $(1000+(F35.00-100))*(F35.01/100)$ | 1010                |
| 100           | 120           | $(1000+(F35.00-100))*(F35.01/100)$ | 1200                |
| 105           | 103           | $(1000+(F35.00-100))*(F35.01/100)$ | 1035                |
| 95            | 95            | $(1000+(F35.00-100))*(F35.01/100)$ | 945                 |

Notes:

### F36 Side B Wayne Vac A/L Calibration Data

This function provides a way to calibrate the Wayne Vac A/L ratio.

There is an adder and a multiplier that can be used to change the ratio. The adder has more effect at the low flow rates (lower RPMs) and the multiplier has more effect at the higher flows (higher RPMs).

**.00** Default setting is 100, which is a 0 adder. To increase RPMs increase the number above 100. To decrease RPMs make the number lower than 100.

**.01** Default setting is 100, which is a 1 multiplier. To increase RPMs increase the number above 100. To decrease RPMs make the number lower than 100.

The example below shows how the adder and multiplier affect the motor speed.

Assume the speed is set at 1000 RPM, then:

| <b>F36.00</b> | <b>F36.01</b> | <b>Calculation</b>                 | <b>Result (RPM)</b> |
|---------------|---------------|------------------------------------|---------------------|
| 100           | 100           | $(1000+(F36.00-100))*(F36.01/100)$ | 1000                |
| 110           | 100           | $(1000+(F36.00-100))*(F36.01/100)$ | 1010                |
| 100           | 120           | $(1000+(F36.00-100))*(F36.01/100)$ | 1200                |
| 105           | 103           | $(1000+(F36.00-100))*(F36.01/100)$ | 1035                |
| 95            | 95            | $(1000+(F36.00-100))*(F36.01/100)$ | 945                 |

Notes:

### **F96 Upload Flash Memory - (Upload Code to PC)**

This function requires the laptop and service terminal program (STP). See Section 8 for a step by step procedure.

Press ENTER to transmit the flash program data. The service terminal program requests a filename to upload the data to. Select the file to begin the **(code rev)** upload.

When the flash program upload finishes, the computer goes back to function entry mode where other functions may access.

### **F97 Upload Configuration - (Upload Template to PC)**

This function requires the laptop and service terminal program (STP). See Section 8 for a step by step procedure.

Press ENTER to transmit the flash template data. The service terminal program requests a filename to upload the data to. Select the file to begin the **template** upload.

When the flash template upload is complete, the computer will go back to function entry mode where other functions may access. See Section 8 for a step by step procedure.

### **F98 Download Flash Memory - (Download Code to Dispenser)**

This function requires the laptop and service terminal program (STP). See Section 8 for a step by step procedure.

Press ENTER to download a verification code and display the word PASS. Enter the two digit verification code. The service terminal program on the laptop requests a filename to download. You can browse various directories and then select the correct **(code rev)** file to start the download. If you cannot find the file or if there is a CRC error, the download will abort.

It is important that you do not interrupt the download for any reason - clicking on or opening other items on the desktop while the download is in progress will cause the download to abort. If this happens, you will have to load the flash via the **bootstrap mode**. See Section 8 for the bootstrap mode procedure.

When the download is complete, the software executes a warm start which is just like a power cycle. If the laptop is still connected and the laptop program is still running, the computer will re-enter maintenance mode prompting for the passwords to be entered. At this point you can terminate the laptop program and disconnect the laptop, however, you may want to download.

The flash memory programming that is being downloaded contains a default template. If the template that is currently in the flash is *compatible* with the new version of program code, the template data in the flash is preserved. If the template data that is currently in the flash is *incompatible* with the new version of program code, the template data in the flash will be overwritten with the default template.



## F99 Download Configuration - (Download Template to Dispenser)

This function requires the laptop and service terminal program (STP). See Section 8 for a step by step procedure.

Press ENTER to download a verification code and display the word PASS. Enter the two digit verification code. The service terminal program on the laptop requests a filename to download. You can browse various directories and then select the correct **template** file to start the download. If you cannot find the file or if there is a CRC, the download will abort.

If the template download is interrupted, restart the service terminal and reload the template. When the download is complete, the software executes a warm start which is just like a power cycle. If the laptop is still connected and the laptop program is still running, the computer will re-enter maintenance mode prompting for the passwords to be entered. At this point you can terminate the laptop program and disconnect the laptop.

After downloading a new template into the flash, a **Cold Start** using jumper S15 must be done to transfer the new template from flash memory to RAM. See Section 8 for a step by step procedure.

## 6.3 STATISTICS

This section gives a comprehensive list of statistics that can be accessed via the maintenance mode. The statistics are used to read totals and totalizers, and to view event counters, error codes and other diagnostic information. The dispenser template controls access to the statistics. The template contains an access level table that determines what statistics each user has access to. Access levels are as follows:

Read and Write

Read only

No access

Unless otherwise noted in the list below, all statistics that compile values of *totals can be reset to zero* using the IR remote control. Statistics that compile values of *totalizers cannot be reset to zero* using the remote control.

To reset a statistic of totals using the IR remote, perform the following:

Access the statistic and sub-statistic

Press # key (display will show *CLEAR TOTALS*)

Press ENTER (display will show *PASS*)

Enter \_\_ (two digit password)

Go to Function 00 and select 03 to Save and Exit

Statistics that can be accessed through the Maintenance Mode are listed on the following pages:

### **S01 Side A Totals by Logical Nozzle**

The values of these statistics can be reset to zero. Sub-statistic numbers in the format .TN, where

T = totals type:

- 1 = Volume
- 2 = Total Money
- 3 = Credit
- 4 = Cash
- 5 = Serial Filling Mode Filling Count
- 6 = Stand Alone Mode Filling Count

N = logical nozzle number 0-8 (0 = none assigned)

Example: Unit price display shows "1.21". The 1 represents statistic S01 and values shown in the volume display would be the total money 2 for nozzle 1.

The least significant six digits of the data value appear on the volume display. Higher order non-zero digits of the data value, if present, appear on the money display. Leading zeros appear as blanks.

### **S02 Side B Totals by Logical Nozzle**

The values of these statistics can be reset to zero. Sub-statistic numbers in the format .TN, where

T = totals type:

- 1 = Volume
- 2 = Total Money
- 3 = Credit
- 4 = Cash
- 5 = Serial Filling Mode Filling Count
- 6 = Stand Alone Mode Filling Count

N = logical nozzle number 0-8 (0 = none assigned)

The least significant six digits of the data value appear in the volume display with higher order non-zero digits of the data value, if present, shown on the money display. Leading zeros appear as blanks.

### **S03 Side A Error/Event Counter Totals**

The values of these statistics can be reset to zero. The money display is in the form of dashes and sub-statistic displays on the unit price display in the range 1-99 representing the set of error/events detectable by the program. The allowed range for the counter value is 0-255. See the troubleshooting section for a listing of the error codes.

### **S04 Side B Error/Event Counter Totals**

The values of these statistics can be reset to zero. The money display is in the form of dashes and sub-statistic displays on the unit price display in the range 1-99 representing the set of error/events detectable by the program. The allowed range for the counter value is 0-255. See the troubleshooting section for a listing of the error codes.

### **S05 Side A Meter Volume Totals**

The values of these statistics can be reset to zero. Sub-statistic numbers in the format .M0, where M = meter number 1-8. The least significant six (6) digits of the data value appear on the volume display. Higher order non-zero digits of the data value, if present, appear on the money display. Leading zeros appear as blanks.

### **S06 Side B Meter Volume Totals**

The values of these statistics can be reset to zero. Sub-statistic numbers in the format .M0, where M = meter number 1-8. The least significant six (6) digits of the data value appear on the volume display. Higher order non-zero digits of the data value, if present, appear on the money display. Leading zeros appear as blanks.

### **S07 - S10: Reserved**

### **S11 Side A Totalizers by Logical Nozzle**

The values of these statistics cannot be reset to zero. Sub-statistic numbers in the format .TN, where

T = Totals type

1 = Volume

2 = Total Money

3 = Credit

4 = Cash

5 = Serial Filling Mode Filling Count

6 = Stand Alone Mode Filling Count

N = logical nozzle number 0-8, where 0 = none assigned

The least significant six digits of the data value appear on the volume display. Higher order non-zero digits of the data value, if present, appear on the money display. Leading zeros appear as blanks.

### **S12 Side B Totalizers by Logical Nozzle**

The values of these statistics cannot be reset to zero. Sub-statistic numbers in the format .TN, where

T = Totals type

1 = Volume

2 = Total Money

3 = Credit

4 = Cash

5 = Serial Filling Mode Filling Count

6 = Stand Alone Mode Filling Count

N = logical nozzle number 0-8, where 0 = none assigned

The least significant six digits of the data value appear on the volume display. The higher order non-zero digits of the data value, if present, appear on the money display. Leading zeros appear as blanks.

**S13 Side A Error/Event Counter Totalizers**

The values of these statistics cannot be reset to zero. The money display shows dashes and the volume display shows the statistic data. The unit price display shows the statistic and sub-statistic numbers in the format 13.XX, where .XX is in the range 0-99 representing the set of error/events detectable by the program. The allowed range for the counter value is 0-999.

**S14 Side B Error/Event Counter Totalizers**

The values of these statistics cannot be reset to zero. The money display shows dashes and the volume display shows the statistic data. The unit price display shows the statistic and sub-statistic numbers in the format 14.XX, where .XX is in the range 0-99 representing the set of error/events detectable by the program. The allowed range for the counter value is 0-999.

**S15 Side A Meter Volume Totalizers**

The values of these statistics cannot be reset to zero. Sub-statistic numbers in the format .M0, where M = meter number 1-8. The least significant six digits of the data value appear on the volume display. The higher order non-zero digits of the data value, if present, appear on the money display. Leading zeros appear as blanks.

**S16 Side B Meter Volume Totalizers**

The values of these statistics cannot be reset to zero. Sub-statistic numbers in the format .M0, where M = meter number 1-8. The least significant six digits of the data value appear on the volume display. The higher order non-zero digits of the data value, if present, appear on the money display. Leading zeros appear as blanks.

**S17 - S20: Reserved**

## S21 Side A Error/Event Log

and

## S22 Side B Error/Event Log

Access statistics S21 and S22 to read error codes. Sub-statistic numbers are in the format .XX with the range of 01-50 representing the set of error/events records maintained by the program. The record in sub-statistic 01 is the most recent error code or event. The error log data is displayed using a two data page format, alternating between page 1 and page 2 each second. See the troubleshooting section for a listing of the error codes.

Page 1 has the format:

.HH.MM                    - Money Display -  
CC.DD.NN                 - Volume Display -

Page 2 has the format:

MM.DD.YY  
          C

HH = hour  
MM = minute  
CC = error code  
DD = device number  
NN = logical nozzle number

MM = month  
DD = day  
YY = year  
C = filling count

Page 1 has the event time on the money display in the format HH.MM. The volume display has data in the format CC.DD.NN where CC = the error/event code in the range 1-99, DD = the device number associated with the error/event and NN = the logical nozzle 0-8 selected at detection of the event (0 = none selected).

Page 2 shows the event date on the money display in the format MM.DD.YY and the filling count for the side on the volume display.

### **S23 Side A Transaction History Log**

and

### **S24 Side B Transaction History Log**

Access statistics S23 and S24 to view the money, volume, and unit price for each of the last 10 transactions. Sub-statistic numbers are in the format .XX with the range of 01-10 representing the set of transaction records maintained by the program. The record displayed in sub-statistic 01 is the most recent and 10 is the oldest. The transaction history records are displayed using a two data page format, alternating between page 1 and page 2 each second.

Page 1 shows the transaction sale amount on the money display and transaction volume amount on the volume display.

Page 2 shows the unit price on the money display and the transaction volume on the volume display.

### **S25 Total Number of Power Cycles**

The money display is blank and the power cycle counter value appears on the volume display. Sub-statistic numbers are displayed in the format 0X where X = the selected parameter defined as follows:

0. Number of Power Cycles
1. Number of Software Resets
2. Number of Cold Start Power Cycles

### **S26 Reset History**

This statistic provides information for a software engineer to aid in troubleshooting. It shows the date, time, reason, and return location for the last 50 resets. Sub-statistic numbers in the format .XX with the range 01-50 representing the set of reset event records maintained by the program. The record displayed in sub-statistic 01 is the most recent and 50 is the oldest.

Records are displayed using a two data page format, alternating between page 1 and page 2 each second.

Page 1 shows the event time on the Money display in the format HH.MM. The volume display has data in the format TT.FFFF where TT = the trap id, FFFF = the value of the trap flag register, (TFR) at detection of the reset.

Page 2 shows the event date on the Money display in the format MM.DD.YY and the return address as SS.OOOO where SS is the hex code segment, and OOOO is the hex offset into the code segment. The return address can be used to determine the PC contents when the trap occurred. This can be especially helpful for unexpected traps such as illegal instructions, odd word fetches, etc.

## 6.4 WEIGHTS AND MEASURES MODE

If you enter the maintenance mode through the weights and measures entry, a special weights and measures mode version of the maintenance mode automatically starts. This mode is designed to display the blend ratio change event logs (if a blender) and volume metering change event logs required by Weights and Measures.

Note: The Weights and Measures mode is side specific. It shows the blend ratio logs and volume metering unit logs for the side that you are facing when using the IR remote, however, neither side of the dispenser is available for customer use while in this mode.

To enter the Weights and Measures mode:

Press CLEAR twice on the IR remote control.

If the dispenser is configured as a blender, you enter the View Blend Ratios mode first. After you finish viewing the blend ratio or if the dispenser is not configured as a blender, the View Volume Metering Unit Change Counters mode (see following page) begins automatically within 20 seconds - or by pressing the CLEAR key.

When you enter the **View Blend Ratios mode**, the sale display contains the words bLEnd rAtioS and the current blend ratios for all the blended products are displayed in the current price display for a maximum of 20 seconds or until you press NEXT, at which time the system goes into the **View Blend Ratio Change Counters mode**. The sale display will show n, where n is the unit change event number.

Press NEXT to toggle through each blend ratio change counter. When all products finish displaying, pressing the NEXT button (or by system default) enters into the View Volume Metering Unit Change Counters mode.

In the View Blend Ratio Change Counters mode, the corresponding unit price display shows **Pr n** where **n** is the product number, also known as the logical nozzle number.

The money display contains the current counter value, which is how many times this product's blend ratio has changed. The volume display contains the current blend ratio.

Press the ENTER key to go into the **View Blend Ratio Change Event Logs mode**.

In this mode, the following sequence repeats every 20 seconds for the last ten event logs for the selected product. When all ten event logs are finished displaying, control returns to the previous mode.

The corresponding unit price display contains **bC n** where **n** is the blend change event number (1-10) where 1 is the last blend change event and 10 is the oldest stored change event.

The sale display alternates every two seconds between the following:

The money display displays either **LOCAL** or **SErIAL** depending on whether the blend ratio change came from local programming or from the serial link to the site controller and the volume display contains the blend ratio that it was changed to with this event.

The money display contains the date of the event in the form of mm.dd.yy, where mm is the month, dd is the day, yy is the year. The volume display contains the time of the event in the form of hh.mm where hh is the hour (0-23) and mm is the minute (0-59).

## 6.4 WEIGHTS AND MEASURES MODE, continued

If the dispenser is not configured as a blender, the **View Volume Metering Unit Change Counters mode** is entered automatically when you enter the Weights and Measures mode. If the dispenser is a blender, the mode is entered as explained on the previous page.

In this mode, the following items display for 20 seconds:

Unit price displays contain **Unit** (for volume metering unit)

Money price display contains the current counter value showing how many times the volume metering unit was displayed

Volume display contains the current volume metering unit described as follows:

**LitErs** Liters volume unit

**US GAL** U.S. Gallons volume unit

**IP GAL** Imperial Gallons volume unit

If you press the CLEAR key while in this mode, the system exits the Weights and Measures Mode. If you press the ENTER key, the system enters the **View Volume Metering Unit Change Event Logs mode**.

In this mode, the following sequence repeats every 20 seconds for the last ten event logs for the volume metering unit changes. When all ten event logs have finished displaying, control returns to the previous mode. The corresponding unit price display contains **UC n** where **n** is the unit change event number 1-10. 1 is the last unit change event and 10 is the oldest stored change event.

The sale display alternates every two seconds between the following:

The money display is blank and the volume display contains the metering unit that was changed to with this event described as follows:

**LitErs** Liters volume unit

**US GAL** U.S. Gallons volume unit

**IP GAL** Imperial Gallons volume unit

The money display contains the date of the event - mm.dd.yy where mm is the month, dd is the day, yy is the year. The volume display contains the time of the event in the form of hh.mm where hh is the hour (0-23) and mm is the minute (0-59).



## 7. TROUBLESHOOTING, ERROR CODES AND SOLUTIONS

This section provides a description of error codes, symptoms and corrective actions. In addition, the computer's on-board LED indicators described in Section 9 also aid in troubleshooting.



### **WARNING**

#### **Electric Shock Hazard!**

**Some of the following corrective actions in this section may require the electrical power to the equipment be ON. Use wiring diagrams, connector drawings and other information in this manual to identify the electrical connections and AVOID contact with the electrical power. Failure to do so may result in severe injury or death.**

This section also describes the two means available to read the error codes: via the IR remote or the laptop. However, in most repairs involving the pump computer, both will be used. For example, use the remote to view the error code, and if the error is with the computer, use the laptop to re-flash the pump code or template as explained in Section 8, and then, the remote again to reprogram unit prices, fueling point number, etc.

### **7.1 USING THE IR REMOTE TO VIEW STATISTICS**

Use the IR remote control to enter the Maintenance Mode and access statistics S21 and S22 to view error codes and event logs as follows:

```
press ENTER
enter Password _ _ _ _
press ENTER
enter Password again _ _ _ _
press ENTER
enter Statistic number
```

### **7.2 USING THE SERVICE TERMINAL PROGRAM (STP)**

The Service Terminal Kit, part number 887722-001, includes the RS232 adapter board and cable, which in addition to the Service Terminal Program software and the IR remote, are required to perform some of the corrective actions given in this section.

The STP allows a laptop computer to communicate with the pump computer through an RS232 link to access dispenser functions and diagnostic data (statistics). Although you perform the programming through the pump display, a description of the various functions and statistics appear on the laptop display.

The procedure for using the service terminal to enter the Maintenance Mode is as follows:

1. Disconnect the J1 DC power connector on the computer board.
2. Install the RS232 cable between the laptop and the RS232 adapter board. Connect the adapter board to J18 on the computer board.
3. With the Service Terminal Program on the laptop closed, re-connect J1 power on the computer board.
4. Start the Service Terminal Program. The STP will start communicating with the pump computer and the dispenser will go into the maintenance mode.

**TABLE 7-1. ERROR CODES AND SOLUTIONS**

| <b>Error Code</b> | <b>Description</b>   | <b>Probable Cause</b>  | <b>Corrective Action</b>  |
|-------------------|--|--|---|
| 1                 | Flash Program CRC Error  | Corrupt Flash Program Area   | Bootstrap & Re-Flash Program or Replace computer base   |
| 2                 | Flash Template CRC Error   | Corrupt Or Incompatible Flash Template Area  | Download correct template<br>Replace computer base  |
| 3                 | Reserved   |  |   |
| 4                 | Reserved   |  |   |
| 5                 | RAM Error Log CRC Error  | Corrupt RAM Error Log Data   | Re-Flash Program or Replace computer base   |
| 6                 | RAM Function Programming CRC Error   | Corrupt RAM Function Data  | Re-Flash Program or Replace computer base   |
| 7                 | RAM Unit Prices CRC Error  | Corrupt RAM Unit Price Data  | Re-Flash Program or Replace computer base   |
| 8                 | RAM Statistics CRC Error   | Corrupt RAM Statistics Data  | Re-Flash Program or Replace computer base   |
| 9                 | RAM Event Logs CRC Error   | Corrupt RAM Event Log Data   | Re-Flash Program or Replace computer base   |
| 10                | RAM Totals CRC Error   | Corrupt RAM Totals Data  | Re-Flash Program or Replace computer base   |
| 11                | RAM Totalizers CRC Error   | Corrupt RAM Totalizer Data   | Re-Flash Program or Replace computer base   |
| 12                | RAM Electro-mech Totalizers CRC Error  | Corrupt RAM EMT Data   | Re-Flash Program or Replace computer base   |
| 13                | Reserved   |  |   |
| 14                | Reserved   |  |   |
| 15                | Reserved   |  |   |
| 16                | Suppress Overflow Limit Reached - Function 19.12-.22   | Slow down limit too low<br><br>Defective flow control valve                                    | Adjust slow down volume - (Dispenser or POS)<br>Replace valve   |
| 17                | Reserved   |  |   |
| 18                | Reserved   |  |   |
| 19                | Reserved   |  |   |
| 20                | n Consecutive Display Read Back Error -<br>Device #s: 0 = Sales,<br>1 = Unit Price, 2 = Preset | Defective display board or cable<br>Defective preset board or cable<br>Defective computer base | Replace display board or cable<br>Replace preset board of cable<br>Re-Flash Program & Template or Replace computer base |
| 21-24             | Reserved   |  |   |
| 25                | Sale Cannot Start - 0 Unit Price   | Unit price not set   | Set unit price  |
| 26                | Sale Cannot Start - No Unit Price Downloaded   | POS has not set a unit price   | Set unit price on POS   |

|       |   |   |  |
|-------|---|---|--|
| 27    | Sale Cannot Start - Unit Price Changed – Function 23.04 | Unit price has changed prior to start of sale   | Check setting function 23.04   |
| 28    | Sale Cannot Start - Need Preset Entry – Function 24.01  | Sale requires an entry from preset keypad   | Check function 24.01   |
| 29    | Reserved  |   |  |
| 30    | No Communications with POS Timeout – Function 23.02     | Communication lost with POS   | Verify data-link connection & polarity to POS.   |
| 31    | Reserved  |   |  |
| 32    | Reserved  |   |  |
| 33    | Sale Aborted Because Stop Button Was Pushed             | Stop button pushed or stop button defective   | Verify stop button functionality   |
| 34    | Reserved  |   |  |
| 35    | Blend Ratio Out of Tolerance - Function 7.02            | Inlet pressures too low, too high<br>Product flow restriction   | Check inlet pressures<br>Check product flow paths - (filters strainer, valves...)  |
| 36-41 | Reserved  |   |  |
| 42    | Vapor Recovery Motor On When It Should Be Off           | Cables plugged into wrong position on Wayne Vac control board<br>Wrong dispenser Template installed<br>Defective Wayne Vac control board<br>Defective computer board<br><br>Defective Wayne Vac motor | Reconnect cables to control board per wiring diagram<br>Re-Flash program & template<br>Replace Wayne Vac control bd<br>Replace computer and re-flash program & template<br>Replace Motor |
| 43    | Vapor Recovery Motor Off When It Should Be On           | Cables plugged into wrong position on Wayne Vac control board<br>Wrong dispenser Template installed<br>Defective Wayne Vac control board<br>Defective computer board<br><br>Defective Wayne Vac motor | Reconnect cables to control board per wiring diagram<br>Re-Flash program & template<br>Replace Wayne Vac control bd<br>Replace Computer and re-flash program & template<br>Replace motor |
| 44    | Reserved  |   |  |
| 45    | Reserved  |   |  |
| 46    | Vapor Recovery Motor Turning Wrong Direction            | Defective Wayne Vac motor or cables<br>Defective Wayne Vac control board  | Replace<br><br>Replace   |
| 47    | Illegal Sensor States from Vapor Recovery System        | Defective Wayne Vac motor or cables<br>Defective Wayne Vac control board  | Replace<br><br>Replace   |
| 48    | Vapor Recovery Motor - Load High                        | Blocked vapor path<br><br>Defective Wayne Vac pump  | Check A/L (see troubleshooting guide in manual p/n 917947)<br>Check for debris/broken rotor.<br>Repair or replace motor.   |
| 49    | Vapor Recovery Motor - Load Low                         | Defective Wayne Vac motor   | Check for broken rotor<br>Replace rotor or motor   |

|       |   |   |   |
|-------|---|---|---|
| 50    | Jitter Limit Reached on an In Transaction Pulser                        | Defective Pulser  | Replace   |
| 51    | Jitter Limit Reached on an Idle Pulser                                  | Defective Pulser  | Replace   |
| 52    | Jitter Limit Reached on an Illegal Pulser                               | Defective Pulser  | Replace   |
| 53    | Reserved  |   |   |
| 54    | Reserved  |   |   |
| 55    | Reverse Flow Limit Reached on an Illegal Pulser                         | Defective check valve   | Replace   |
| 56    | Forward Flow Limit Reached on an Idle Pulser                            | Defective flow control valve  | Replace   |
| 57    | Forward Flow Limit Reached on an Illegal Pulser                         | Defective computer  | Re-Flash Program & Template or Replace computer base                                  |
| 58    | Communications Lost to an In Transaction Pulser                         | Defective Pulser<br>Defective ISB or cables   | Replace<br>Replace  |
| 59    | Communications Lost to an Idle Pulser                                   | Defective Pulser<br>Defective ISB or cables   | Replace<br>Replace  |
| 60    | Reserved  |   |   |
| 61    | Reserved  |   |   |
| 62    | Pulser is Outputting Jitter   | Volume of fuel dispensed during a meter calibration exceeded limits.<br>Defective Pulser                                | Replace Pulser  |
| 63-66 | Reserved  |   |   |
| 67    | Pulser Calibration OK Bit Status Changed                                | Pulser has been calibrated  |   |
| 68    | Pulser Calibration Door Status Changed                                  | Pulser cal door was opened or closed  |   |
| 69    | Pulser Last Calibration Status Changed                                  | Pulser last calibration successful.   |   |
| 70    | Timeout Limit Reached for No Flow – Function 17.02 (flow never started) | Defective flow control valve or cables<br>Defective pump motor/control, relay<br>Defective nozzle<br>Defective computer | Replace<br>Replace<br>Replace<br>Replace  |
| 71    | n Consecutive No Flow Timeouts – Function 17.03                         | Defective flow control valve or cables<br>Defective pump motor/control, relay<br>Defective nozzle<br>Defective computer | Replace<br>Replace<br>Replace<br>Re-Flash Program & Template or Replace computer base |

|       |   |   |   |
|-------|---|---|---|
| 72    | Timeout Limit Reached for Flow Lost – Function 17.02 (flow lost during sale)                          | Defective flow control valve or cables<br>Defective pump motor/control, relay<br>Defective nozzle<br>Defective computer | Replace<br>Replace<br>Replace<br>Re-Flash Program & Template or Replace computer base |
| 73    | n Consecutive Flow Lost Timeouts – Function 17.04   | Defective flow control valve or cables<br>Defective pump motor/control, relay<br>Defective nozzle<br>Defective computer | Replace<br>Replace<br>Replace<br>Re-Flash Program & Template or Replace computer base |
| 74    | Sale Terminated before Preset Limit Reached/Unfinish Filling  | Defective flow control valve or cables<br>Defective pump motor/control, relay<br>Defective nozzle<br>Defective computer | Replace<br>Replace<br>Replace<br>Re-Flash Program & Template or Replace computer base |
| 75    | n Consecutive Unfinish Fillings   | Defective flow control valve or cables<br>Defective pump motor/control, relay<br>Defective nozzle<br>Defective computer | Replace<br>Replace<br>Replace<br>Re-Flash Program & Template or Replace computer base |
| 76-79 | Reserved  |   |   |
| 80    | Mail Buffer Memory Pool Exhausted – (Internal Error)  | Defective computer  | Replace computer base   |
| 81-98 | Reserved  |   |   |
| 99    | Hardware/Software Mismatch - Device #s:<br>0 = No Proportional Hardware,<br>1 = No Vapor Rec Hardware | Defective Wayne Vac control board or cable<br>Defective computer  | Replace<br>Re-Flash Program & Template or Replace computer base                       |

See board layouts in Section 9 for identification and location of connectors and LED indicators.

**TABLE 7-2. SYMPTOMS AND SOLUTIONS**

| Symptom                              |   | Probable Cause                      | Corrective Action   |
|--------------------------------------|---|-------------------------------------|---|
| Sale and Unit Price Displays are out | 1 | No AC power to dispenser            | Check control power circuit breaker.<br>Check check for AC input voltage at J3 on Relay Board.<br>If not present check in J-box. If not present in J-box, problem is in site wiring. If present in J-box, problem is in internal dispenser wiring.<br>Check LED indicators on computer for DC power and Heart-beat (see board layout for LEDs). If all are On, see Probable Cause 6 and 7. If all not On, see Probable Cause 5. |
|                                      | 2 | No DC power to computer             | All LEDs should be On. DS6 is 24v input LED. Check for 24 VDC input at Computer J1.<br>If present, see Probable Cause 7.<br>If not present, check at DC Distr Board J4 output, fuse F1, and J1 input. If present at J1, see Probable Cause 3.<br>If not present at J1, check at Power Supply Board J2 output, J1 input. If present at J1, see Probably Cause 4.<br>If not present at J1, see Probable Cause 5.                  |
|                                      | 3 | Defective 24V DC Distribution board | Replace fuse F1 or board as necessary.  |
|                                      | 4 | Defective P/S board                 | Replace power supply assembly   |
|                                      | 5 | Defective Relay board               | Check fuse F1 on Relay board; if bad, replace board.  |
|                                      | 6 | Defective display                   | Replace board   |
|                                      | 7 | Defective computer                  | Replace board   |
|                                      |   |                                     |   |

**TABLE 7-2. SYMPTOMS AND SOLUTIONS, continued**

| <b>Symptom</b>                                      |   | <b>Probable Cause</b>  | <b>Corrective Action</b>  |
|---|---|--|---|
| Unit Price Displays read 0.000                      | 1 | Control system unit price set at 0.000.  | Set correct unit price in control system.   |
|   | 2 | Unit price not set at dispenser. If a control system is connected see Cause 3. | Set correct price function F03 and F04.   |
|   | 3 | Fueling point # not set. If a control system is not connected go to Step 5.    | Set fueling point function F01.01.  |
|   | 4 | Defective computer.  | Replace computer board  |
|   |   |  |   |
| Display Segments Fail to Operate During Reset Cycle | 1 | Defective display  | Replace board   |
|   | 2 | Defective data cable   | Replace data cable  |
|   | 3 | Defective computer   | Replace board   |
|   |   |  |   |
|   |   |  |   |
| Dispenser will not Reset                            | 1 | Unit prices 0.000  | See above symptom.  |
|   | 2 | No authorize to dispenser computer.  | Check control system & filling mode function F01.01 =1. If stand-alone, check F01.01 =2 |
|   | 3 | Defective Nozzle switch  | Repair/Replace switch   |
|   | 4 | Defective PTS switch   | Repair/Replace switch   |
|   | 5 | Defective Computer   | Replace computer board  |
|   |   |  |   |





## **8. PROCEDURES FOR UPLOADING AND DOWNLOADING FILES**

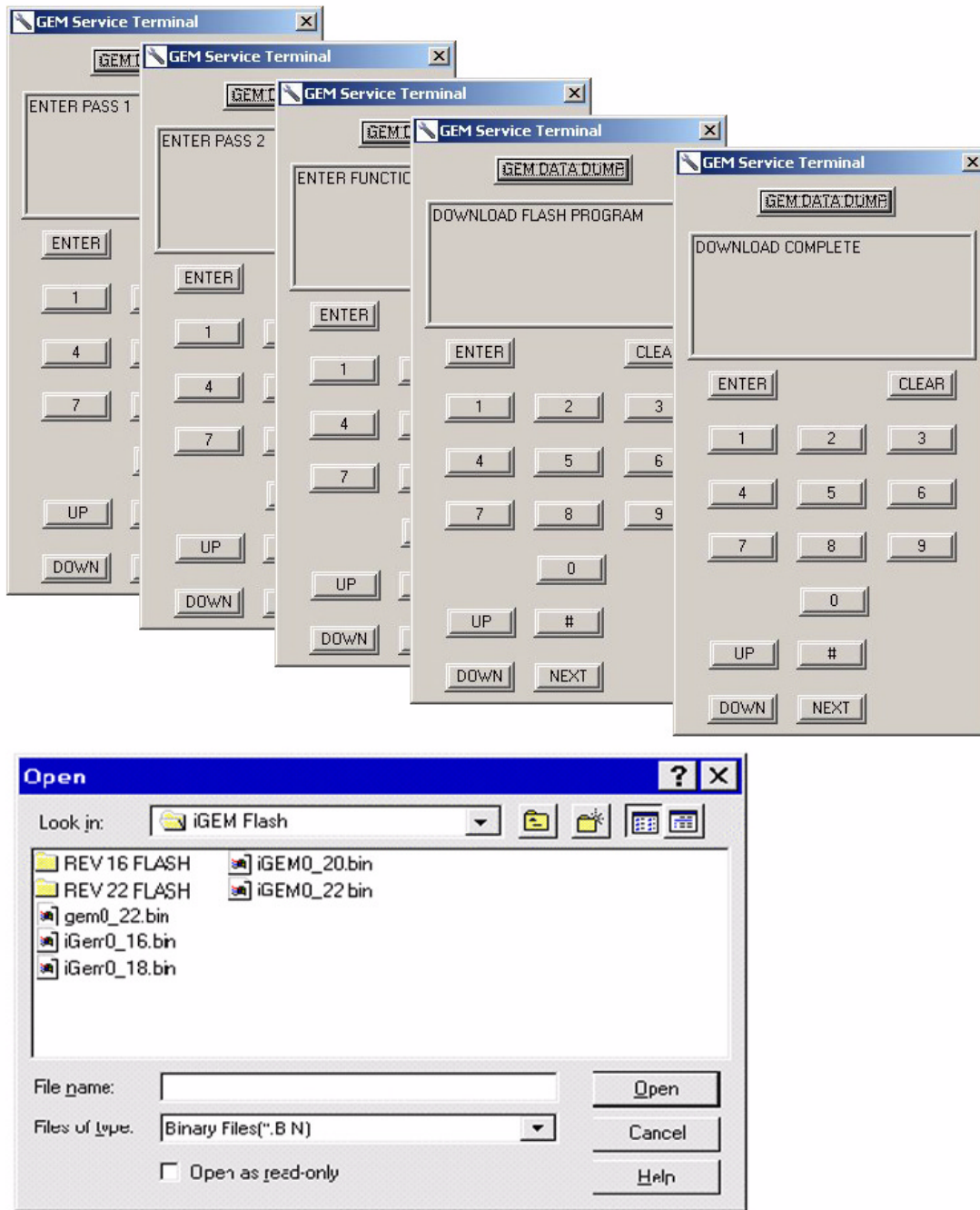

**FIGURE 8-1. SERVICE TERMINAL SCREENS THAT APPEAR ON THE LAPTOP.** *These are some of the screens that will appear on the laptop as the procedures on the following page are performed.*

## 8.1 UPLOADING AND DOWNLOADING PUMP CODE AND TEMPLATES.

Power down the pump. Connect laptop via RS-232 cable and adapter to J18 on computer board. Power up pump first, and then, open the Service Terminal Program (STP) on the laptop, then

```

press  ENTER
enter  Pass 1 _ _ _ _
press  ENTER
enter  Pass 2 _ _ _ _
press  ENTER
enter  Function number below
    
```

| 96 | To upload code to pc    | 97 | To upload template to pc | 98 | To download code to dispenser           | 99 | To download template to dispenser                   |
|----|-------------------------|----|--------------------------|----|---|----|---|
|    | press ENTER             |    | press ENTER              |    | press ENTER                             |    | press ENTER   |
|    | upload flash program    |    | upload template          |    | download flash program                  |    | download template                                   |
|    | press ENTER             |    | press ENTER              |    | press ENTER                             |    | press ENTER   |
|    | select the filename     |    | select the filename      |    | enter 2-digit password _ _              |    | enter 2-digit password _ _                          |
|    | press ENTER             |    | press ENTER              |    | press ENTER                             |    | press ENTER   |
|    | uploading blocks begins |    | uploading blocks begins  |    | browse/select filename gem_ _ .bin      |    | browse/select the proper template                   |
|    | upload complete         |    | upload complete          |    | waiting for flash to erase <sup>1</sup> |    | waiting for flash to erase <sup>1</sup>             |
|    | Close STP               |    | Close STP                |    | downloading blocks begins               |    | downloading blocks begins                           |
|    |                         |    |                          |    | download complete                       |    | download complete                                   |
|    |                         |    |                          |    | Close STP <sup>2</sup>                  |    | Close STP <sup>2</sup>                              |
|    |                         |    |                          |    | power down pump                         |    | power down pump                                     |
|    |                         |    |                          |    | remove RS232 & laptop                   |    | remove RS232 & laptop                               |
|    |                         |    |                          |    | power up pump                           |    | jumper S15 Cold Start                               |
|    |                         |    |                          |    |   |    | power up pump                                       |
|    |                         |    |                          |    |   |    | display reads <i>COLD</i>                           |
|    |                         |    |                          |    |   |    | remove S15 jumper                                   |
|    |                         |    |                          |    |   |    | program prices, fueling point, etc., with IR remote |

1. If this process is now interrupted for any reason, the Bootstrap procedure must then be used to download to the dispenser, therefore, do not run other programs or perform other actions on the desktop. See Bootstrap Procedure on the following page.
2. After briefly displaying "Download Complete", the laptop will display "Enter Password" assuming you may want to proceed to other functions, however, you should Close STP at this time and finish the above procedure and then access other functions using the IR remote.

## 8.2 BOOTSTRAP PROCEDURE

The Bootstrap procedure listed below must be performed if: 1) after selecting filename or template in Function 98 or 99, the process of downloading to the pump computer is interrupted, or 2) a pump computer is installed that does not have pump software code already onboard. To Bootstrap the 3/Vista computer:

1. Power down pump
2. Follow procedure in Table 8-1 for connecting laptop
3. Jumper S13 Bootstrap on computer base
4. Power up pump
5. Remove S13 jumper
6. Run the Service Terminal Program
7. Complete the remaining procedure for Function 98 or 99.

## **9. ELECTRONIC BOARDS - INDICATORS, LAYOUTS AND PINOUTS**

## 9.1. COMPUTER BOARD LED INDICATORS

### Processor Activity Indicator

DS1: Red (Heartbeat) LED indicates processor activity. It will be blinking on and off at a steady rate as long as the processor is running properly.

### Power Indicators

These LEDs only indicate the presence of a voltage. They do not assure that the levels are correct.

DS6: Green LED indicates that the board is connected to power source on its 24VDC input line.

DS7: Green LED indicates that the board is generating 5VDC to power the logic.

DS8: Green LED indicates that the board is generating 8VDC for use on board and to power associated assemblies.

DS13: Green LED indicates that the board is generating 15VDC which is used to power the attached WIPs.

DS14: Green LED indicates that the board is generating 5VDC for use onboard.

### Communication Activity Indicators

#### *POS Communications:*

DS5: Red LED indicates activity on the Host Receive Line. The LED is on when the line is low.

DS12: Green LED indicates activity on the Transmit Line. The LED is on when the line is low.

#### *Display Bit Bus Side 1 and 2 Communications:*

DS3: Red LED indicates activity on Receive Line. The LED is on when the line is high.

DS9: Green LED indicates activity on the Transmit Line. The LED is on when the line is high.

#### *WIP (Pulsers) Communications:*

DS4: Red LED indicates activity on Receive Line. The LED is on when the line is low.

DS11: Green LED indicates activity on the Transmit Line. The LED is on when the line is low.

#### *CAN Bus Communications (Used for Harmony, Ovation dispensers):*

DS2: Red LED indicates activity on Receive Line.

DS10: Green LED indicates activity on the Transmit Line.

These two LEDs flash very briefly; for example, at Authorize, PTS selection, or CAT activity.

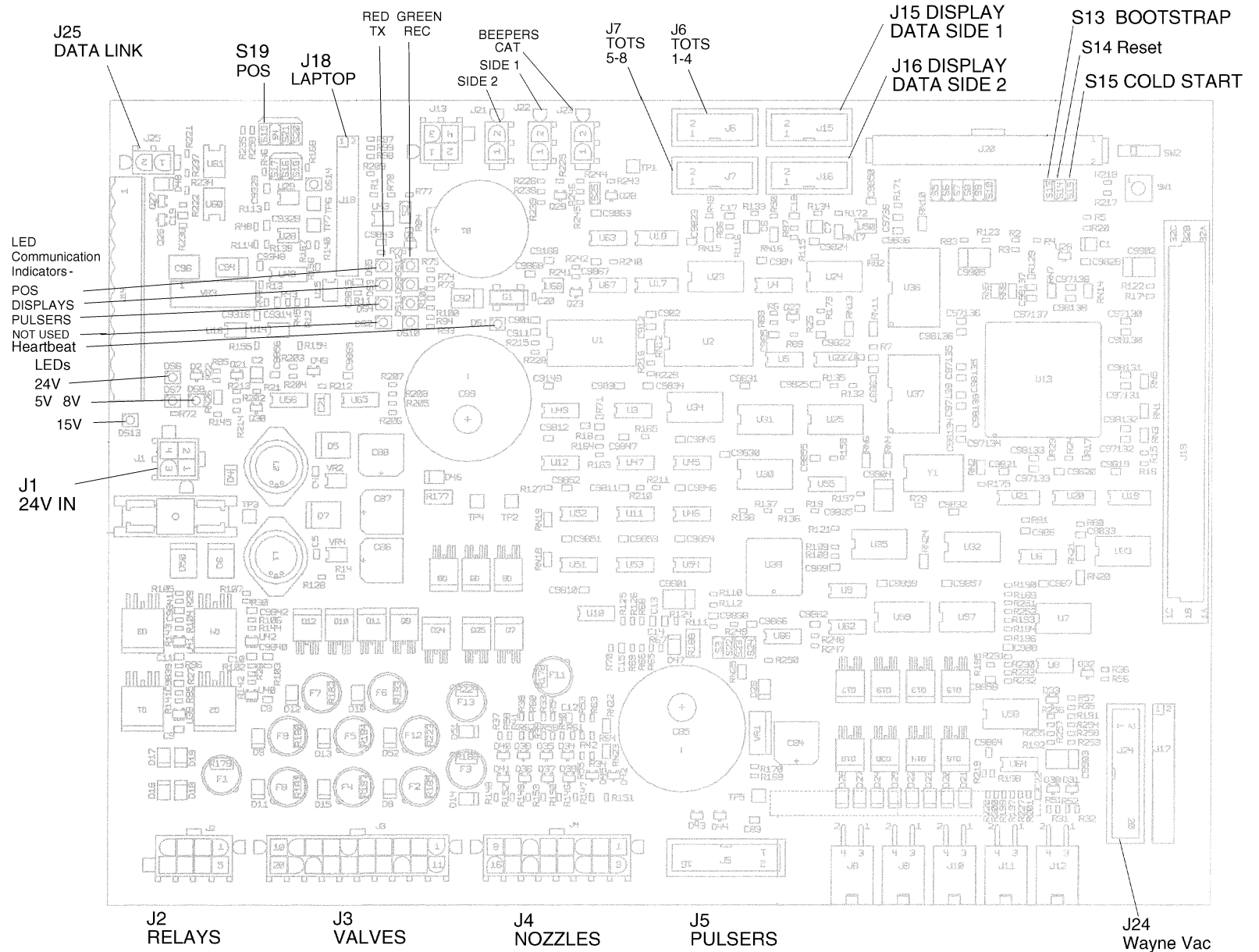

FIGURE 9-1. COMPUTER BOARD LAYOUT.

## 9.2. COMPUTER BOARD CONNECTOR PINOUTS

| Connector and Pin # | Description     | Connects To               | Note   |
|---------------------|-----------------|---------------------------|--|
| <b>J1</b>           | 24 VDC In       | 24V DC Distribution Bd J4 | Typical Reading 23.9-24.1V   |
| 1                   | 24V             |                           |  |
| 2                   | 24V             |                           |  |
| 3                   | GND             |                           |  |
| 4                   | GND             |                           |  |
|                     |                 |                           |  |
| <b>J2</b>           | Sub Pump Relays | Relay Board J1            | Typical Readings 23.9-24.1V  |
| 1                   | 24 VDC          |                           |  |
| 2                   | Pump Motor 2    |                           |  |
| 3                   | 24 VDC          |                           |  |
| 4                   | Pump Motor 1    |                           |  |
| 5                   | 24 VDC          |                           |  |
| 6                   | Pump Motor 4    |                           |  |
| 7                   | 24 VDC          |                           |  |
| 8                   | Pump Motor 3    |                           |  |
|                     |                 |                           |  |
| <b>J3</b>           | Valve Outputs   | Proportional Valves       | Typical Voltage Readings for checking the operation of the proportional valves.<br>MGDs:<br>slow flow 8Vdc<br>fast flow 19 Vdc<br>Blenders:<br>slow flow or fast flow 8-19 Vdc |
| 1                   | GND             |                           |  |
| 2                   | 24V             | Valve #9                  |  |
| 3                   | GND             |                           |  |
| 4                   | 24V             | Valve #4                  |  |
| 5                   | GND             |                           |  |
| 6                   | 24V             | Valve #3                  |  |
| 7                   | GND             |                           |  |
| 8                   | 24V             | Valve #2                  |  |
| 9                   | GND             |                           |  |
| 10                  | 24V             | Valve #1                  |  |
| 11                  | GND             |                           |  |
| 12                  | 24V             | Valve #10                 |  |
| 13                  | GND             |                           |  |
| 14                  | 24V             | Valve #8                  |  |
| 15                  | GND             |                           |  |
| 16                  | 24V             | Valve #7                  |  |
| 17                  | GND             |                           |  |
| 18                  | 24V             | Valve #6                  |  |
| 19                  | GND             |                           |  |
| 20                  | 24V             | Valve #5                  |  |



## 9.2 COMPUTER BOARD PINOUTS, continued

| Connector and Pin # | Description          | Connects To | Note                       |
|---------------------|----------------------|-------------|----------------------------|
| <b>J4</b>           | Nozzle Switch Inputs | ISB J7      | Typical Reading 5V         |
| 1                   | GND                  |             |                            |
| 2                   | NOZZ 4               |             |                            |
| 3                   | GND                  |             |                            |
| 4                   | NOZZ 3               |             |                            |
| 5                   | GND                  |             |                            |
| 6                   | NOZZ 2               |             |                            |
| 7                   | GND                  |             |                            |
| 8                   | NOZZ 1               |             |                            |
| 9                   | GND                  |             |                            |
| 10                  | NOZZ 8               |             |                            |
| 11                  | GND                  |             |                            |
| 12                  | NOZZ 7               |             |                            |
| 13                  | GND                  |             |                            |
| 14                  | NOZZ 6               |             |                            |
| 15                  | GND                  |             |                            |
| 16                  | NOZZ 5               |             |                            |
|                     |                      |             |                            |
| <b>J5</b>           | WIP IN/OUT           | ISB J1      | Typical Reading 14.8-15.2V |
| 1                   | 15 VDC               |             |                            |
| 2                   | GND                  |             |                            |
| 3                   | WIP1 REC             |             |                            |
| 4                   | WIP1 TX              |             |                            |
| 5                   | GND                  |             |                            |
| 6                   | WIP2 REC             |             |                            |
| 7                   | WIP2TX               |             |                            |
| 8                   | GND                  |             |                            |
| 9                   | GND                  |             |                            |
| 10                  | WIP3 REC             |             |                            |
| 11                  | WIP3 TX              |             |                            |
| 12                  | GND                  |             |                            |
| 13                  | WIP4 REC             |             |                            |
| 14                  | WIP4 TX              |             |                            |
| 15                  | GND                  |             |                            |
| 16                  | 15 VDC               |             |                            |
|                     |                      |             |                            |
|                     |                      |             |                            |
|                     |                      |             |                            |

## 9.2 COMPUTER BOARD PINOUTS, continued

| Connector and Pin #  | Description             | Connects To           | Note |
|----------------------|-------------------------|-----------------------|------|
| <b>J6</b>            | Totalizers from Side1   | Outputs from Tots 1-4 |      |
| 1                    | 24V                     |                       |      |
| 2                    | TOT 1                   |                       |      |
| 3                    | 24V                     |                       |      |
| 4                    | TOT 2                   |                       |      |
| 5                    | 24V                     |                       |      |
| 6                    | TOT 3                   |                       |      |
| 7                    | 24V                     |                       |      |
| 8                    | TOT 4                   |                       |      |
| 9                    | N/C                     |                       |      |
| 10                   | N/C                     |                       |      |
|                      |                         |                       |      |
| <b>J7</b>            | Totalizers from Side2   | Outputs from Tots 5-8 |      |
| 1                    | 24V                     |                       |      |
| 2                    | TOT5                    |                       |      |
| 3                    | 24V                     |                       |      |
| 4                    | TOT6                    |                       |      |
| 5                    | 24V                     |                       |      |
| 6                    | TOT7                    |                       |      |
| 7                    | 24V                     |                       |      |
| 8                    | TOT8                    |                       |      |
| 9                    | N/C                     |                       |      |
| 10                   | N/C                     |                       |      |
|                      |                         |                       |      |
| <b>J8</b>            | BackLight Output        |                       |      |
| 1                    | SIDE A 24V              |                       |      |
| 2                    | GND                     |                       |      |
| 3                    | SIDE B 24V              |                       |      |
| 4                    | GND                     |                       |      |
|                      |                         |                       |      |
| <b>J9</b>            | Red/Green Light Outputs |                       |      |
| 1                    | SIDE A 24V              |                       |      |
| 2                    | GND                     |                       |      |
| 3                    | SIDE B 24V              |                       |      |
| 4                    | GND                     |                       |      |
|                      |                         |                       |      |
| <b>J10, J11, J12</b> | SPARE IN/OUT            |                       |      |

## 9.2 COMPUTER BOARD PINOUTS, continued

|            |                                       |                   |   |
|------------|---------------------------------------|-------------------|---|
| <b>J13</b> | CAN BUS I/O                           |                   | Future use for Harmony and Ovation Dispensers |
| 1          | TX/RC +                               |                   |   |
| 2          | TX/RC -                               |                   |   |
| 3          | 24V                                   |                   |   |
| 4          | GND                                   |                   |   |
|            |                                       |                   |   |
| <b>J14</b> | Euro DataLink                         |                   | Not used in U.S.                              |
|            |                                       |                   |   |
| <b>J15</b> | Display Data Cable Bit Bus Side A (1) | Side 1 Display J1 |   |
| 1          | DATA IN A                             |                   |   |
| 2          | DATA OUT A                            |                   |   |
| 3          | ADDRESS BIT A                         |                   |   |
| 4          | CLOCK A                               |                   |   |
| 5          | BUZZER A                              |                   |   |
| 6          | STOP A                                |                   |   |
| 7          | 8 VDC                                 |                   | Typ reading 7.8 - 8.2 Vdc                     |
| 8          | GND                                   |                   |   |
| 9          | REMOTE                                |                   |   |
| 10         | GND                                   |                   |   |
|            |                                       |                   |   |
| <b>J16</b> | Display Data Cable Bit Bus Side B (2) | Side 2 Display J1 |   |
| 1          | DAT IN B                              |                   |   |
| 2          | DATA OUT B                            |                   |   |
| 3          | ADDRESS BIT B                         |                   |   |
| 4          | CLOCK B                               |                   |   |
| 5          | BUZZER B                              |                   |   |
| 6          | STOP B                                |                   |   |
| 7          | 8VDC                                  |                   | Typ reading 7.8 - 8.2 Vdc                     |
| 8          | GND                                   |                   |   |
| 9          | REMOTE                                |                   |   |
| 10         | GND                                   |                   |   |
|            |                                       |                   |   |
| <b>J21</b> | BUZZER POWER SIDE 2                   |                   |   |
| 1          | 8V                                    |                   |   |
| 2          | BUZZER 2                              |                   |   |
|            |                                       |                   |   |

## 9.2 COMPUTER BOARD PINOUTS, continued

| Connector and Pin # | Description               | Connects To     | Note  |
|---------------------|---------------------------|-----------------|---|
| <b>J22</b>          | BUZZER POWER<br>SIDE 1    |                 |   |
| 1                   | 8V                        |                 |   |
| 2                   | BUZZER 1                  |                 |   |
|                     |                           |                 |   |
| <b>J23</b>          | CAT BUZZER                |                 |   |
| 1                   | GND                       |                 |   |
| 2                   | BUZZ CAT                  |                 |   |
|                     |                           |                 |   |
| <b>J24</b>          | WAYNE VAC                 | WAYNE VAC BD J2 |   |
| 1                   | VAC CONNECTED<br>(YES/NO) |                 |   |
| 2                   | FREEZING TEMP             | Thermostat      |   |
| 3                   | WAYNE VAC ID 0            |                 |   |
| 4                   | WAYNE VAC ID 1            |                 |   |
| 5                   | ORVR B                    |                 |   |
| 6                   | MOTOR SPEED B             |                 |   |
| 7                   | MOTOR STATUS B1           |                 |   |
| 8                   | MOTOR STATUS B0           |                 |   |
| 9                   | ORVR A                    |                 |   |
| 10                  | MOTOR SPEED A             |                 |   |
| 11                  | MOTOR STATUS A1           |                 |   |
| 12                  | MOTOR STATUS A0           |                 |   |
| 13                  | RUN MOTOR A               |                 |   |
| 14                  | DIR MOTOR A               |                 |   |
| 15                  | RUN MOTOR B               |                 |   |
| 16                  | DIR MOTOR B               |                 |   |
| 17                  | RESET                     |                 |   |
| 18                  | GND                       |                 |   |
| 19                  | CLOCK                     |                 |   |
| 20                  | GND                       |                 |   |
|                     |                           |                 |   |
| <b>J25</b>          | DATALINK                  | DATALINK PAIR 1 | S19 must have jumper for<br>communications with POS |
| 1                   | DATA +                    |                 |   |
| 2                   | DATD -                    |                 |   |

9.3. ISB BOARD ASSY PINOUTS

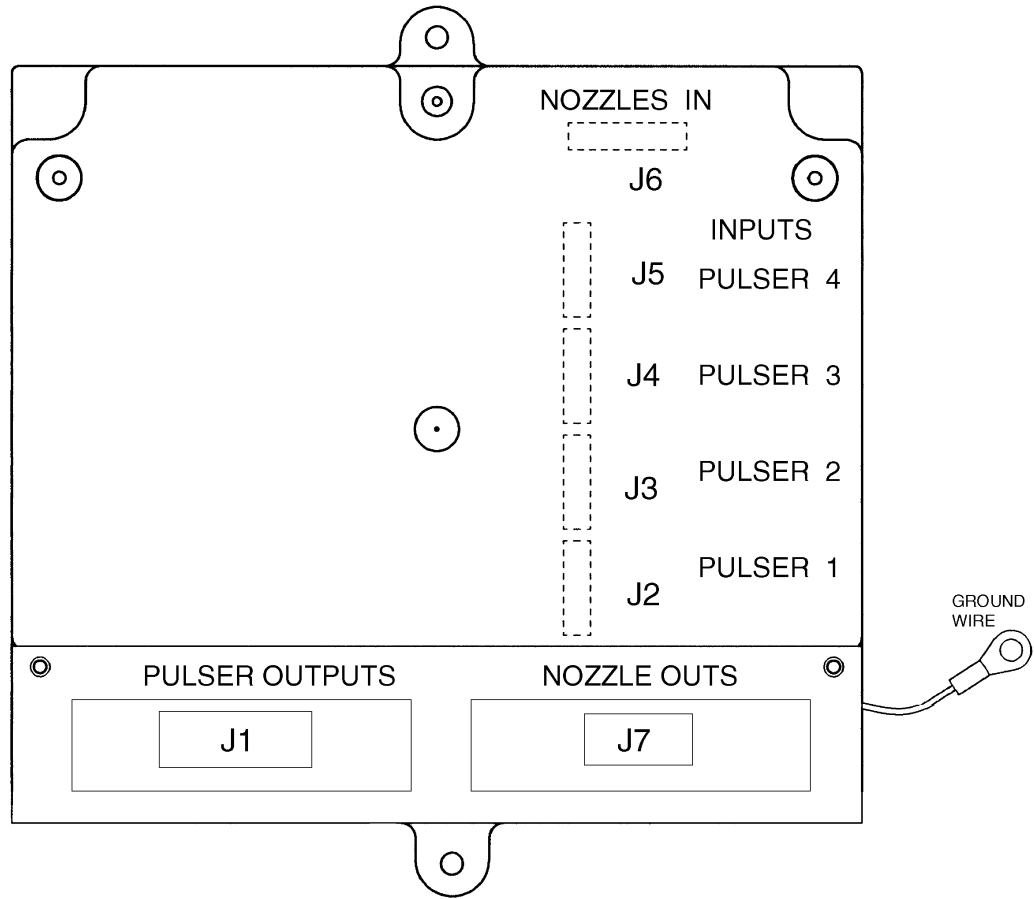

FIGURE 9-2. ISB BOARD ASSY. LAYOUT.

9.3 ISB BOARD ASSY PINOUTS, continued

| Connector and Pin # | Description     | Connects To | Note                        |
|---------------------|-----------------|-------------|-----------------------------|
| <b>J1</b>           | WIP Pulsers 1-4 | Computer J5 |                             |
| 1                   | POWER 1 15V     |             | Typ reading 14.2 - 15.8 vdc |
| 2                   | GND             |             |                             |
| 3                   | RC 1            |             |                             |
| 4                   | TX 1            |             |                             |
| 5                   | GND             |             |                             |
| 6                   | RC 2            |             |                             |
| 7                   | TX 2            |             |                             |
| 8                   | GND             |             |                             |
| 9                   | GND             |             |                             |
| 10                  | RC 3            |             |                             |
| 11                  | TX 3            |             |                             |
| 12                  | GND             |             |                             |
| 13                  | RC 4            |             |                             |
| 14                  | TX 4            |             |                             |
| 15                  | GND             |             |                             |
| 16                  | POWER 2 15V     |             |                             |
| <b>J2</b>           |                 | PULSER 1    |                             |
| 1                   | TX              |             |                             |
| 2                   | RC              |             |                             |
| 3                   | GND             |             |                             |
| 4                   | 15V             |             |                             |
| 5                   | N/C             |             |                             |
| 6                   | N/C             |             |                             |
| 7                   | N/C             |             |                             |
| 8                   | N/C             |             |                             |
| <b>J3</b>           |                 | PULSER 2    |                             |
| 1                   | TX              |             |                             |
| 2                   | RC              |             |                             |
| 3                   | GND             |             |                             |
| 4                   | 15V             |             |                             |
| 5                   | N/C             |             |                             |
| 6                   | N/C             |             |                             |
| 7                   | N/C             |             |                             |
| 8                   | N/C             |             |                             |
| <b>J4</b>           |                 | PULSER 3    |                             |
| 1                   | TX              |             |                             |
| 2                   | RC              |             |                             |
| 3                   | GND             |             |                             |
| 4                   | 15V             |             |                             |
| 5                   | N/C             |             |                             |
| 6                   | N/C             |             |                             |
| 7                   | N/C             |             |                             |
| 8                   | N/C             |             |                             |
| <b>J5</b>           |                 | PULSER 4    |                             |
| 1                   | TX              |             |                             |
| 2                   | RC              |             |                             |
| 3                   | GND             |             |                             |
| 4                   | 15V             |             |                             |
| 5                   | N/C             |             |                             |
| 6                   | N/C             |             |                             |
| 7                   | N/C             |             |                             |
| 8                   | N/C             |             |                             |

**9.3 ISB BOARD ASSY PINOUTS, continued**

| <b>Connector and Pin #</b> | <b>Description</b> | <b>Connects To</b> | <b>Note</b>               |
|----------------------------|--------------------|--------------------|---------------------------|
| <b>J7</b>                  | NOZ Switch Outputs | Computer J4        | Typ reading 4.9 - 5.2 VDC |
| 1                          | NOZ 1              |                    |                           |
| 2                          | NOZ 2              |                    |                           |
| 3                          | NOZ 3              |                    |                           |
| 4                          | NOZ 4              |                    |                           |
| 5                          | NOZ 5              |                    |                           |
| 6                          | NOZ 6              |                    |                           |
| 7                          | NOZ 7              |                    |                           |
| 8                          | NOZ 8              |                    |                           |
| 9                          | GND                |                    |                           |
| 10                         | GND                |                    |                           |
| <b>J6</b>                  | NOZ Switch Inputs  | Nozzles            |                           |
| 1                          | NOZ 1              |                    |                           |
| 2                          | NOZ 2              |                    |                           |
| 3                          | NOZ 3              |                    |                           |
| 4                          | NOZ 4              |                    |                           |
| 5                          | GND                |                    |                           |
| 6                          | NOZ 5              |                    |                           |
| 7                          | NOZ 6              |                    |                           |
| 8                          | NOZ 7              |                    |                           |
| 9                          | NOZ 8              |                    |                           |
| 10                         | GND                |                    |                           |

#### 9.4. 24V DC DISTRIBUTION BOARD PINOUTS

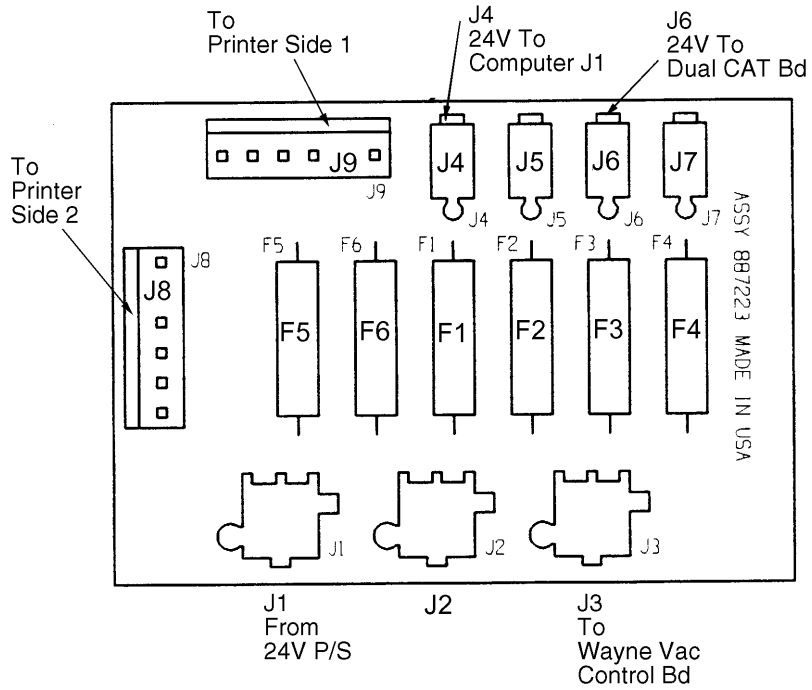

**FIGURE 9-3. 24V DC DISTRIBUTION BOARD.**



#### 9.4 24VDC DISTRIBUTION BOARD PINOUTS, continued

| Connector and Pin # | Description             | Connects To          | Note    |
|---------------------|-------------------------|----------------------|---------|
| <b>J1</b>           | 24VDC INPUT             | 24V P/S Board J2     |         |
| 1                   | 24V IN                  |                      |         |
| 2                   | 24V IN                  |                      |         |
| 3                   | GND                     |                      |         |
| 4                   | GND                     |                      |         |
| <b>J2</b>           | 24VDC Opt Battery Input | For External Battery |         |
| 1                   | 24V                     |                      |         |
| 2                   | 24V                     |                      |         |
| 3                   | GND                     |                      |         |
| 4                   | GND                     |                      |         |
| <b>J3</b>           | 24VDC OUTPUT            | Wayne Vac Board J6   |         |
| 1                   | 24V OUT                 |                      |         |
| 2                   | 24V OUT                 |                      |         |
| 3                   | GND                     |                      |         |
| 4                   | GND                     |                      |         |
| <b>J4</b>           | 24VDC OUTPUT            | Computer J1          | Fuse F1 |
| 1                   | 24V OUT                 |                      |         |
| 2                   | GND                     |                      |         |
| <b>J5</b>           | SPARE 24V OUTPUT        | N/C                  | Fuse F2 |
| <b>J6</b>           | 24VDC OUTPUT            | Dual CAT Board       | Fuse F3 |
| 1                   | 24V OUT                 |                      |         |
| 2                   | GND                     |                      |         |
| <b>J7</b>           | SPARE 24V OUTPUT        | N/C                  | Fuse F4 |
| <b>J8</b>           | 24V                     | Printer Side 1       | Fuse F5 |
| 1                   | 24V                     |                      |         |
| 2                   | N/C                     |                      |         |
| 3                   | 24V                     |                      |         |
| 4                   | GND                     |                      |         |
| 5                   | GND                     |                      |         |
| 6                   | GND                     |                      |         |
| <b>J9</b>           | 24V                     | Printer Side 2       | Fuse F6 |
| 1                   | 24V                     |                      |         |
| 2                   | N/C                     |                      |         |
| 3                   | 24V                     |                      |         |
| 4                   | GND                     |                      |         |
| 5                   | GND                     |                      |         |
| 6                   | GND                     |                      |         |

## 9.5. RELAY BOARD PINOUTS

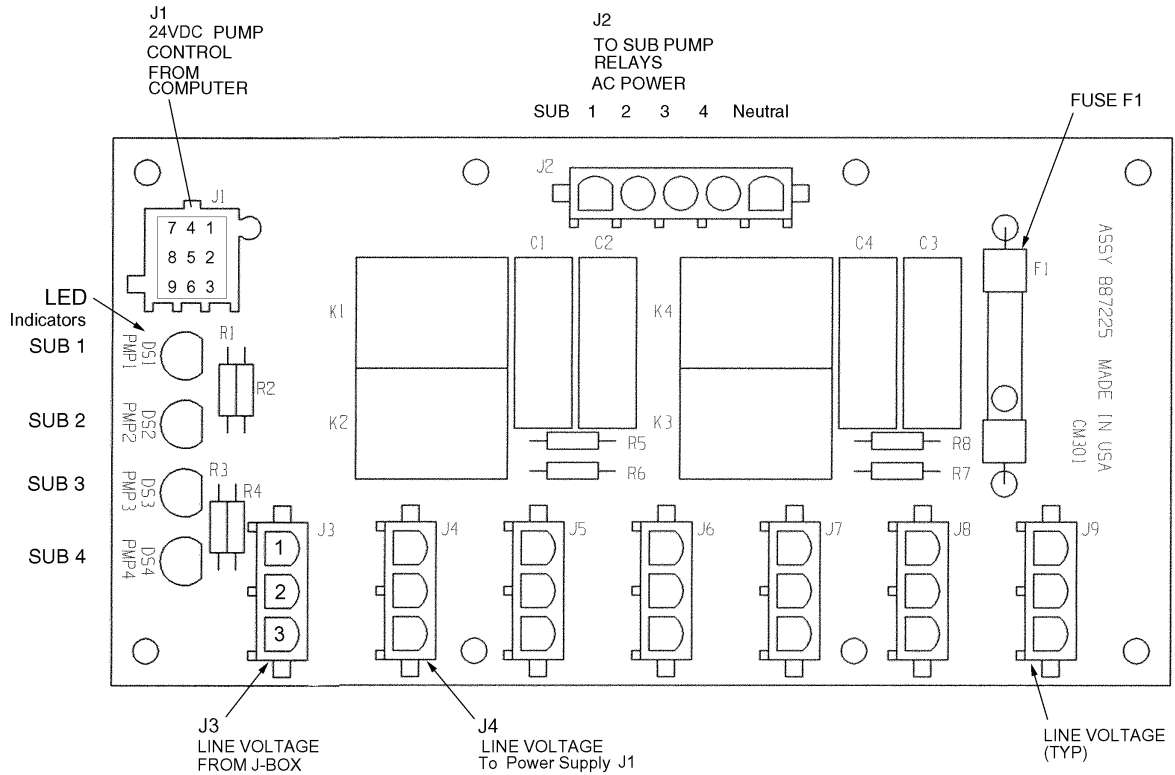
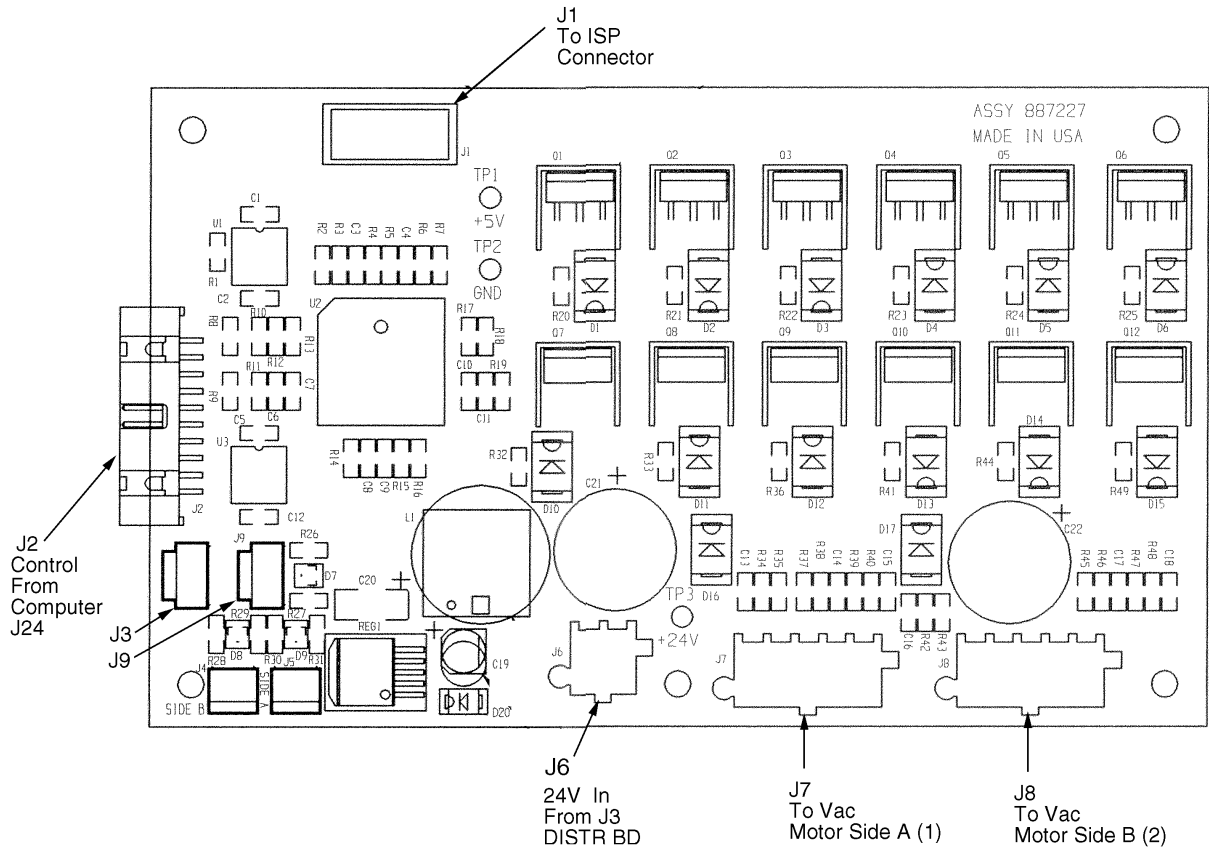

**FIGURE 9-4. RELAY BOARD.**

## 9.5 RELAY BOARD PINOUTS, continued

| Connector and Pin # | Description                              | Connects To Conn / Pin#       | Note                          |
|---------------------|--|-------------------------------|-------------------------------|
| <b>J1</b>           | 24VDC Relay Circuits                     | <b>J2</b> Computer Board      | Typ Reading: 22.8 to 24.8vdc  |
| 1                   | 24V                                      | 3                             |                               |
| 2                   | Sub Pump 1                               | 4                             |                               |
| 3                   | 24V                                      | 1                             |                               |
| 4                   | Sub Pump 2                               | 2                             |                               |
| 5                   | 24V                                      | 7                             |                               |
| 6                   | Sub Pump 3                               | 8                             |                               |
| 7                   | 24V                                      | 5                             |                               |
| 8                   | Sub Pump 4                               | 6                             |                               |
| 9                   | N/C                                      | N/C                           |                               |
| <b>J2</b>           | Switched Line Voltage to Sub Pump Relays | SubPump Wires XYZ AA in B-box |                               |
| 1                   | Sub Pump 1                               | Term 3                        |                               |
| 2                   | Sub Pump 2                               | Term 4                        |                               |
| 3                   | Sub Pump 3                               | Term 5                        |                               |
| 4                   | Sub Pump 4                               | Term 6                        |                               |
| 5                   | Neutral                                  |                               |                               |
| <b>J3</b>           | AC Line Voltage In                       | Control Power in J-Box        |                               |
| 1                   | AC Line                                  | Term 1                        | Fuse F1 Not Field Replaceable |
| 2                   | Neutral                                  | Term 8                        |                               |
| 3                   | GND                                      | GND                           |                               |
| <b>J4</b>           | AC Line Voltage Out                      | 24V P/S Board J1              |                               |
| 1                   | AC Line                                  |                               |                               |
| 2                   | Neutral                                  |                               |                               |
| 3                   | GND                                      |                               |                               |

## 9.6. WAYNE VAC CONTROL BOARD PINOUTS

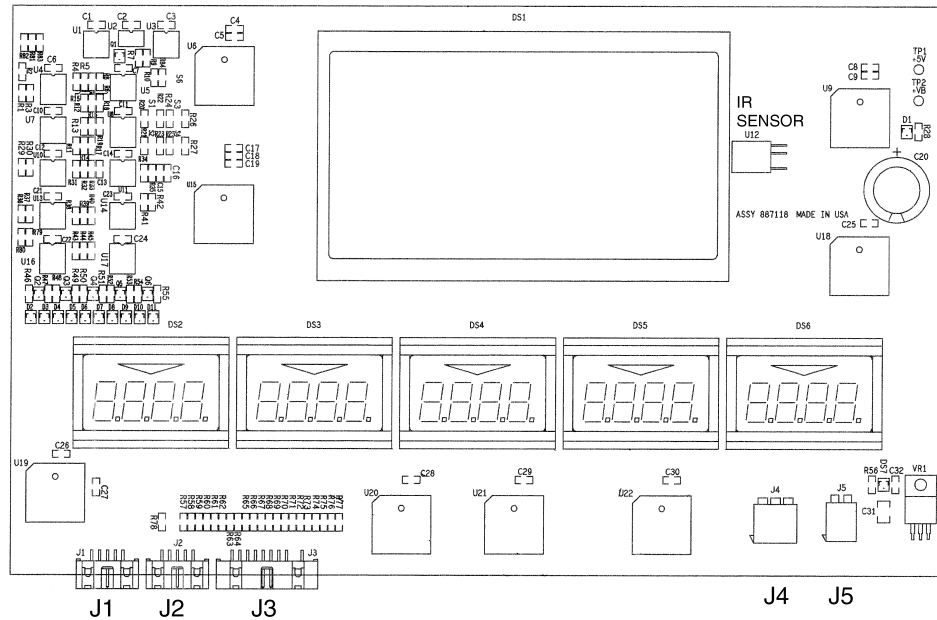

**FIGURE 9-5. WAYNE VAC CONTROL BOARD.**

## 9.6 WAYNE VAC CONTROL BOARD PINOUTS, Continued

| Conn & Pin # | Description               | Connects To              | Note |
|--------------|---------------------------|--------------------------|------|
| <b>J1</b>    | ISP                       | Not Used                 |      |
| 1            | Signal                    |                          |      |
| 2            | GND                       |                          |      |
| 3            | Signal                    |                          |      |
| 4            | 5V                        |                          |      |
| 5            | Signal                    |                          |      |
| 6            | N/C                       |                          |      |
| 7            | N/C                       |                          |      |
| 8            | N/C                       |                          |      |
| 9            | Signal                    |                          |      |
| 10           | GND                       |                          |      |
| <b>J7</b>    | Motor Control             | VAC Motor Side A (1)     |      |
| 1            | 5V                        |                          |      |
| 2            | 5V                        |                          |      |
| 3            | 5V                        |                          |      |
| 4            | 5V                        |                          |      |
| 5            | GND                       |                          |      |
| 6            | Vac Motor                 |                          |      |
| 7            | SW 24V                    |                          |      |
| 8            | PHASE A                   |                          |      |
| 9            | PHASE B                   |                          |      |
| 10           | PHASE C                   |                          |      |
| <b>J8</b>    | Motor Control             | VAC Motor Side B (2)     |      |
| 1            | 5V                        |                          |      |
| 2            | 5V                        |                          |      |
| 3            | 5V                        |                          |      |
| 4            | 5V                        |                          |      |
| 5            | GND                       |                          |      |
| 6            | Vac Motor                 |                          |      |
| 7            | SW 24V                    |                          |      |
| 8            | PHASE A                   |                          |      |
| 9            | PHASE B                   |                          |      |
| 10           | PHASE C                   |                          |      |
| <b>J2</b>    | Computer Control Circuits | Computer Board J24       |      |
| 1            | GND                       |                          |      |
| 2            | CLOCK                     |                          |      |
| 3            | GND                       |                          |      |
| 4            | RESET                     |                          |      |
| 5            | DIR B                     |                          |      |
| 6            | RUN B                     |                          |      |
| 7            | DIR A                     |                          |      |
| 8            | RUN A                     |                          |      |
| 9            | STAT A0                   |                          |      |
| 10           | STAT A1                   |                          |      |
| 11           | SPEED A                   |                          |      |
| 12           | ORVR A                    |                          |      |
| 13           | STAT B0                   |                          |      |
| 14           | STAT B1                   |                          |      |
| 15           | SPEED B                   |                          |      |
| 16           | ORVR B                    |                          |      |
| 17           | TEMP                      |                          |      |
| 18           | GND                       |                          |      |
| 19           | GND                       |                          |      |
| 20           | GND                       |                          |      |
| <b>J6</b>    | POWER IN                  | 24VDC Distribution BD J3 |      |
| 1            | 24V                       |                          |      |
| 2            | 24V                       |                          |      |
| 3            | GND                       |                          |      |
| 4            | GND                       |                          |      |
| J3 and J9    | Thermostat                | Thermostats              |      |

## 9.7. DISPLAY BOARD PINOUTS



**FIGURE 9-6. DISPLAY BOARD.**

| Connector # | Description        | Connects To                           | Note                          |
|-------------|--------------------|---------------------------------------|-------------------------------|
| J1          | Data Cable Bit Bus | Computer J15 or J16                   | J15 Side A (1) J16 Side B (2) |
| J2          | Bezel Functions    | Preset Control Board J2<br>(Optional) |                               |
| J3          | Bezel Functions    | PTS Buttons                           |                               |
| J4          | Bezel Functions    | Stop Switch                           |                               |
| J5          | Bezel Functions    | Authorize Switch (Optional)           |                               |

## 9.8. 24V POWER SUPPLY ASSY PINOUTS

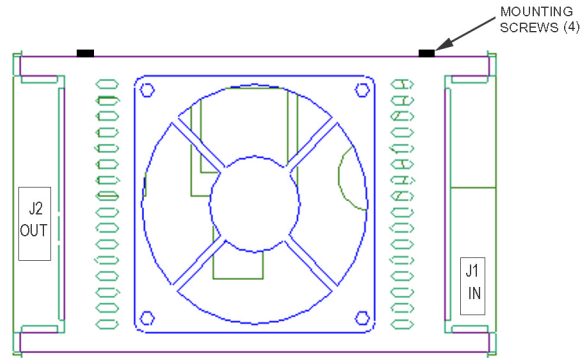

**FIGURE 9-7. POWER SUPPLY ASSEMBLY.**

| Connector and Pin # | Description     | Connects To Conn / Pin#   | Note |
|---------------------|-----------------|---------------------------|------|
| <b>J1</b>           | AC Power Input  | J4 on AC Relay Board      |      |
| 1 BK                |                 | 1                         |      |
| 2                   |                 |                           |      |
| 3 W                 |                 | 2                         |      |
| 4                   |                 |                           |      |
| 5 G                 |                 | 3                         |      |
|                     |                 |                           |      |
| <b>J2</b>           | DC Power Output | 24V DC Distribution Bd J1 |      |
| 1 BK                |                 | 1 BK                      |      |
| 2 BK                |                 | 3 BK                      |      |
| 3 W                 |                 | 2 W                       |      |
| 4 W                 |                 | 4 W                       |      |

## 9.9. DUAL CAT BOARD PINOUTS

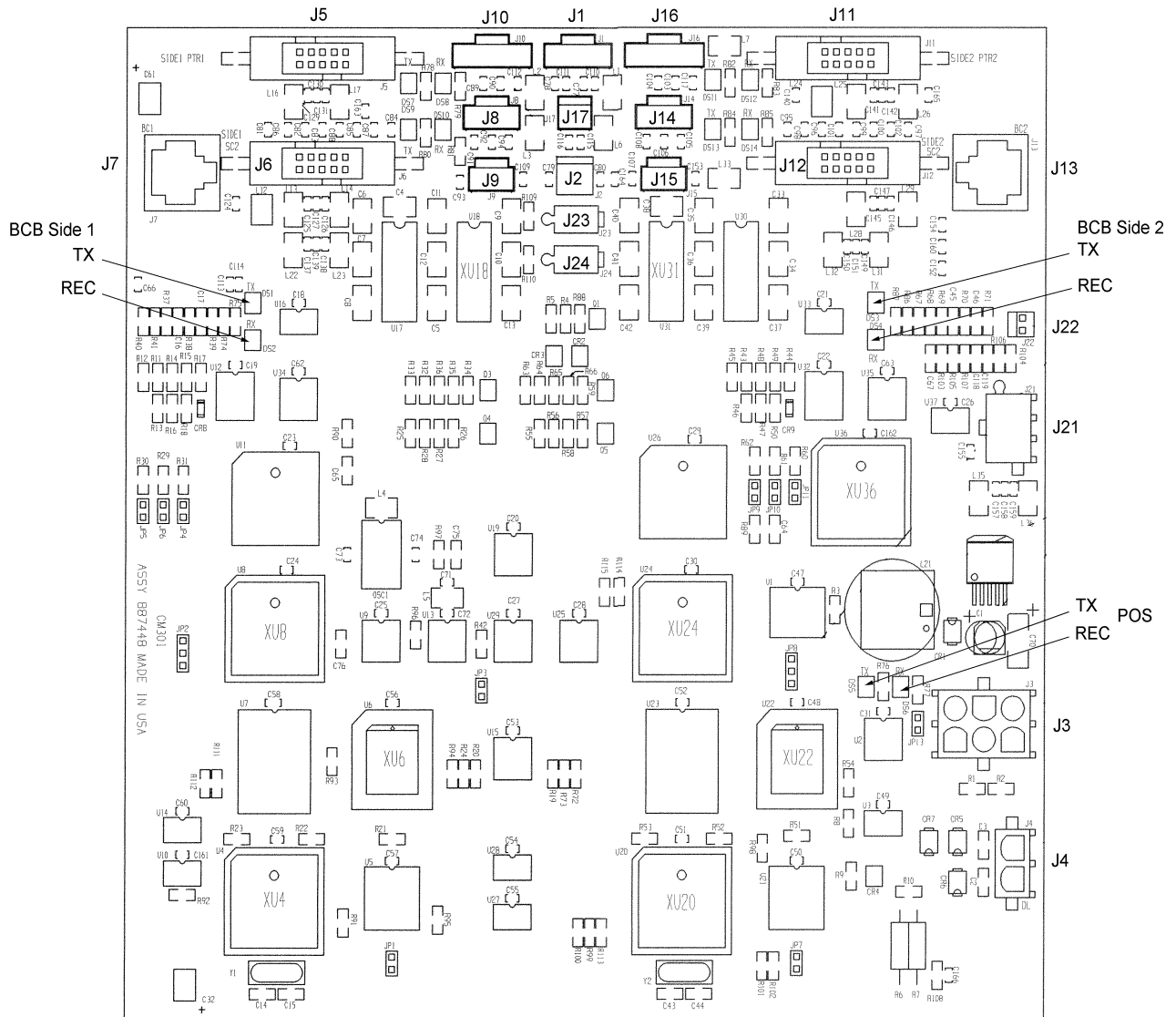

FIGURE 9-8. DUAL CAT BOARD LAYOUT.



## 9.9 DUAL CAT BOARD PINOUTS, continued

| Connector # | Description            | Connects To               | Note |
|-------------|------------------------|---------------------------|------|
| J1          | Annunciator circuit    | Computer                  |      |
| J2          | Annunciator circuit    | Annunciator               |      |
| J3          | 24V Power In           | 24V DC Distribution Board |      |
| J4          | RS485 CAT Data Link    | Pair 2 DL Wiring In J-Box |      |
| J5          | RS232 Port             | Printer Side 1            |      |
| J6          | Spare RS232 Port       | Not used                  |      |
| J7          | CAT Bezel Comm         | BCB J2 Side 1             |      |
| J8          | Sensor 1               | Cash Acceptor Side 1      |      |
| J9          | Sensor 2               | Cash Acceptor Side 1      |      |
| J10         | Cash Acceptor circuits | Cash Acceptor Side 1      |      |
| J11         | RS232 Port             | Printer Side 2            |      |
| J12         | Spare RS232 Port       | Not used                  |      |
| J13         | CAT Bezel Comm         | BCB J2 Side 2             |      |
| J14         | Sensor 1               | Cash Acceptor Side 2      |      |
| J15         | Sensor 2               | Cash Acceptor Side 2      |      |
| J16         | Cash Acceptor circuits | Cash Acceptor Side 2      |      |
| J21         | Spare RS485            | Not used                  |      |
| J22         | Spare for UART         | Not used                  |      |
| J23         | Annunciator circuit    | Annunciator               |      |
| J24         | Annunciator circuit    | Annunciator               |      |



## 10. REPLACEMENT PROCEDURES

This section provides the procedures required for replacing the major components in the dispenser. For board layouts, see Section 9.

Before power is removed from the dispenser, totals should be recorded in case of memory alteration.



### **WARNING**

#### **Electric Shock Hazard!**

**When corrective actions require the electrical power to the equipment be ON, use wiring diagrams, connector drawings and other information in this manual to identify the electrical connections and AVOID contact with the electrical power. Failure to do so may result in severe injury or death.**

As a general rule, when removing and installing electronic boards, take care not to contact the boards with one another. Do not lay spare boards on top one another, since contact between components might cause damage to the circuit board coating, circuit board tracks, or circuit components.

Always keep replacement components in their anti-static shipping bags until they are installed. Put replaced suspect components in the anti-static bags for return to the factory in original packaging and fill out a return parts tag.

Before replacing any components, servicing personnel should wear a static guard wrist strap (part number 916962 or equivalent) securely attached to an earth grounding point in order to prevent damage to electronic components due to static electricity.

After replacing a component, make a thorough visual inspection of your work to ensure the following:

All connections are secure

All mounting hardware is secure

There are no loose washers, screws, tools, etc., lying around which might cause a failure



### **WARNING**

**Before removing any components as described in the following sections, electrical power should be removed from the dispenser. More than one disconnect may be required to remove power. Use a voltmeter to ensure AC power has been removed. Failure to remove the power may result in severe injury or death.**

## 10.1 COMPUTER BOARD REPLACEMENT

When replacing the computer, see the procedure used to re-flash the pump code and template as explained in Section 8. While the new computer board may have pump code on-board, it may not be the latest code and, in some cases, new pump code may not be compatible with the version of the dispenser template on your laptop. Therefore, always use the latest version of pump code and the latest version of the dispenser template to ensure compatibility; the latest versions can be downloaded to your laptop from the Wayne ASONet.

1. Lower both bezels.
2. Disconnect J1 24VDC power cable to computer board.

Note: Interchanging the Bit Bus and EM Totalizers cables will apply 24Vdc to the display board and likely result in damage to the display board, therefore,

3. Tag and disconnect the cables to J15 and J16. (Bit Bus A and Bit Bus B). +8Vdc.
4. Tag and disconnect the cables to J6 and J7. (E-M Tots Side A and Side B). +24Vdc.
5. Disconnect all other wiring to the board.
6. Remove (1) Phillips screw from lower right corner of the board.
7. With hands behind the board, lift the board off the plastic retainers located at the other three corners and lower the board down and out of the head.
8. Install new board using reverse procedure and reconnect all cables.
9. Re-flash the pump code and template as explained in Section 8.1.

## **10.2 ISB ASSEMBLY REPLACEMENT**

The Intrinsic Safe Barrier circuit board is mounted inside the black plastic box near the center of the electronic head. The circuit board itself is not separately replaceable; the complete assembly (the black plastic box) must be replaced. Replace as follows:

1. Lower side 1 bezel.
2. Power down the dispenser at J3 on Relay board.
3. Unplug the two connectors at the top of the ISB assembly.
4. Disconnect the ISB ground wire from chassis.
5. Remove the (2) front and rear screws that secure the assembly to the bottom of the head. The rear screw is directly opposite the front screw, lower side 2 bezel if necessary.
6. Tilt the assembly upwards, unplug the bottom connectors and remove assembly.
7. Replace assembly in reverse order.
8. Double check that the ISB ground wire has been securely connected to chassis.

## **10.3 24V DC DISTRIBUTION BOARD REPLACEMENT**

1. Lower side 1 bezel.
2. Power down the dispenser at J3 on Relay board.
3. Disconnect all wiring to the DC distribution board.
4. Remove (1) Phillips screw at bottom left side of board.
5. Lift board off the (3) plastic retainers at the other three corners of board.
6. Replace in reverse order.

#### **10.4 RELAY BOARD REPLACEMENT**

1. Lower side 1 bezel.
2. Disconnect J3 AC power input to board.
3. Disconnect all other wiring to the board.
4. Remove (4) Phillips screws that secure the board.
5. Lift board off the (4) plastic retainers. If the board does not lift off easily, use needle nose pliers to squeeze top of retainers, then lift the board.
6. Replace in reverse order.

#### **10.5 24V POWER SUPPLY REPLACEMENT**

The 24 Vdc Power Supply is replaced as a complete assembly, which includes the fan.

1. Lower side 1 bezel.
2. Disconnect J3 AC power input to Relay board.
3. Disconnect J1 and J2 (input and output cables) to the Power Supply board.
4. Remove (4) Phillips screws that secure the assembly to the top mounting bracket.
5. Lower the assembly down and out of the head.
6. Replace in reverse order.

#### **10.6 ELECTRO-MECHANICAL TOTALIZER REPLACEMENT**

1. Lower bezel.
2. Remove the 2-pin connector from totalizer.
3. Remove (2) Phillips head screws that secure totalizer to bracket and remove totalizer.
4. Replace in reverse order.

## **10.7 DISPLAY BOARD REPLACEMENT**

1. Lower bezel.
2. Disconnect AC power to backlite.
3. Disconnect Bit Bus data cable at J1 and PTS bezel cable at J3.
4. Disconnect any optional wiring to board.
5. Remove (4) 1/4" nuts from studs holding the backlite/ballast assembly.
6. Lift backlite/ballast assembly off the studs and set aside.
7. Lift display board off the studs.
8. Replace in reverse order.

## **10.8 DUAL CAT BOARD REPLACEMENT**

1. Lower Side 1 bezel.
2. Disconnect J3 AC power input to Relay board.
3. Disconnect all wiring to the board.
4. Remove (2) Phillips screws at top left and bottom left side of board.
5. Lift board off the (2) plastic retainers at top right and bottom right side of board.
6. Replace in reverse order.

## **10.9 WAYNE VAC CONTROL BOARD REPLACEMENT**

3/Vista dispensers use a dual Wayne Vac Control board. The board controls the vapor pump/motors on both sides of the dispenser.

1. Lower Side 1 bezel.
2. Disconnect J3 AC power input to Relay board.
3. Disconnect all wiring to the control board.
4. Remove (1) Phillips screw at bottom right side of board.
5. Lift board off the (3) plastic retainers at the other three corners of board.
6. Replace in reverse order.

## 10.10 PULSER REPLACEMENT

Use Intelligent Pulser Replacement Kit p/n 4-921469-KIT. The kit contains a 4-921087 pulser required for 3/Vista model dispensers.

Refer to Figure 10-1 and replace pulser as follows:

1. Cut and remove the seal wires on both calibration doors on the pulser.
2. Remove and discard the calibration seal slats.
3. Remove the pulser by removing (2) screws that secure the pulser to the meter dome.
4. Discard the sealing bracket.
5. Remove and discard the short pulser cable from the new pulser.  
To remove the pulser wire harness from inside the pulser, press the two plastic tabs on end of pulser, lower (or remove) the plastic cover and remove the rubber cap that covers the small 8-pin connector.
6. Connect the pulser wire harness to the new pulser. Align carefully - misaligned connector pins at the pulser will prevent proper mode setting and calibration. Pin 1 on the connector inside the pulser is located at the bottom of the pulser as shown in Figure 10-1, Detail A.
7. Re-install the rubber cap over top of connector and secure the plastic cover back in place over the rubber cap and cable. Both ends of the cover must be snapped in place.
8. Install the new pulser, along with new sealing bracket, and secure with the (2) screws removed above. Do not install new seal wires at this time.
9. Follow the Pulser Operational Mode setting procedure and the iMeter verification accuracy procedure on the following pages, and, if required, continue with the iMeter calibration procedure.
10. Install new seal slats and seal wires after completing the above steps.



### 10.10.1 Pulser Mode Setting and iMeter Calibration

The Intelligent Pulser contains two sets of hall effect (magnetic) sensors - one set for each meter. Inside the meter dome, a rotating magnetic disk generates a changing magnetic field. The sensors detect changes in the magnetic field which the pulser converts to digital pulses. The pulses are adjusted to meter output with a calibration factor that is stored in the pulser memory.

The pulser has three Operational Modes: U.S. mode, Continental mode, and Euro mode. In the U.S. mode, iMeter calibration is done with a 5 gallon test measure. In the Continental Mode, iMeter calibration is done with a 20 liter test measure. Euro Mode is factory default - factory diagnostics.

The pulser's Operational Mode is determined by the dispenser template loaded into the pump computer's memory. The operational mode tells the pulser which calibration factor will be used for the iMeter calibration process. In other words, the mode identifies the size of the test measure you are using when the amount of product dispensed in the test measure is within one of the predetermined ranges defined for the 5 gallon and the 20 liter measurements. However, if the dispenser is set in one mode (liters for example) and you try to calibrate using the 5 gallon test measure, the pulser will not accept the new calibration factor during this process because the product dispensed in the test measure will not be within the predetermined range. Because this calibration factor is essential for calibrating the iMeter to spec, always ensure the correct mode is set after replacing a pulser or when performing meter calibrations.

**To set the operational mode**, communications between the pump computer and the pulser must be established properly. For 3/Vista model dispensers set the operational mode as follows:

1. Power up the dispenser.
2. Open both calibration doors on the pulser.
3. Cycle power to the dispenser.
4. Close the calibration doors.

iMeters are tested, calibrated and sealed at the factory before a dispenser is shipped. Local codes and regulations may require verification of meter accuracy at Start-up and/or after replacing the pulser. If verification or calibration is required, sufficient product must be run through each meter to thoroughly flush out all air and completely fill the system prior to the calibration process.

Each iMeter module contains two meters. The Intelligent pulser contains two sets of sensors, one set for each meter. On the front of the pulser, there are two calibration doors, one for each meter in the iMeter module. The door closest to the front of the dispenser controls calibration of the front meter and the other door controls calibration of the rear meter. It is important to verify the product grade for each module to assure the correct door is opened during the calibration process.

iMeter verification accuracy and calibration procedures are continued on the following page.

### 10.10.1 Pulsar Mode Setting and iMeter Calibration, continued

#### iMeter Verification Accuracy:

1. Dispense Product into test measure and then empty to wet the test measure.
2. Dispense product into test measure until exactly 5 gallons (20 liters for Continental mode) are shown on dispenser display. See Note 1.
3. Compare reading on site glass of test measure to dispenser display. Volume in test measure should be within +/- 3 cu. in. (+/- 50 ml, Continental mode). See Note 2.
4. If values are out of range, calibrate as described below.

#### iMeter Calibration:

1. Identify the pulser calibration door for meter in need of calibration.
2. Remove, if currently present, the seal wire and slat to allow access to door.
3. Dispense product into test measure and empty to wet container.
4. Open calibration door. (Only one door can be opened at a time during the calibration process).
5. Dispense exactly 5 gallons (20 liters Continental mode) into the test measure exactly to the "0" mark on the sight glass.
6. Close the calibration door. (This now redefines the calibration factor in the pulser).
7. Empty test measure (drain for 10 seconds) and verify accuracy as described above.
8. Seal calibration door.

**Note 1:** In the Continental mode, in addition to 20 liters, a 10 liter or 5 liter test measure may be used if required by the application. However, you should check with your jurisdiction on Weights & Measures tolerance requirements.

**Note 2:** For the U.S. and Canada, tolerance of  $\pm 3$  cu.in. for a 5 gallon measurement and  $\pm 50$  ml for a 20 liter measurement is only required for newly installed, newly placed in service and repaired devices for 30 days. After 30 days, the tolerance is increased to  $\pm 6$  cu.in. for 5 gallons and  $\pm 100$  ml for 20 liters.\*

\* Tolerances are used as accuracy criteria for W & M inspectors. When equipment is being adjusted initially or following repair, the objective should be to adjust as close to zero as possible. Equipment owners and repair technicians should not "take advantage" of tolerances. Equipment will be officially rejected if this is determined true, as referenced in Handbook 44, paragraph G-UR.4.1.

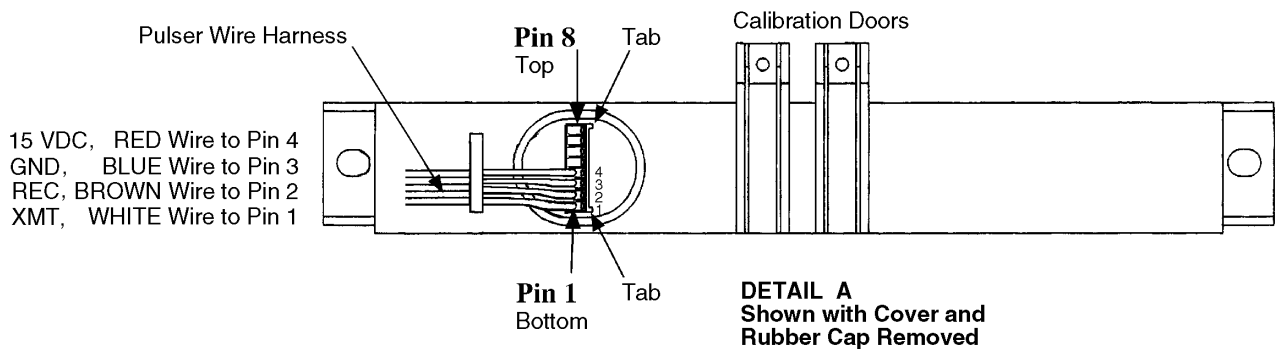
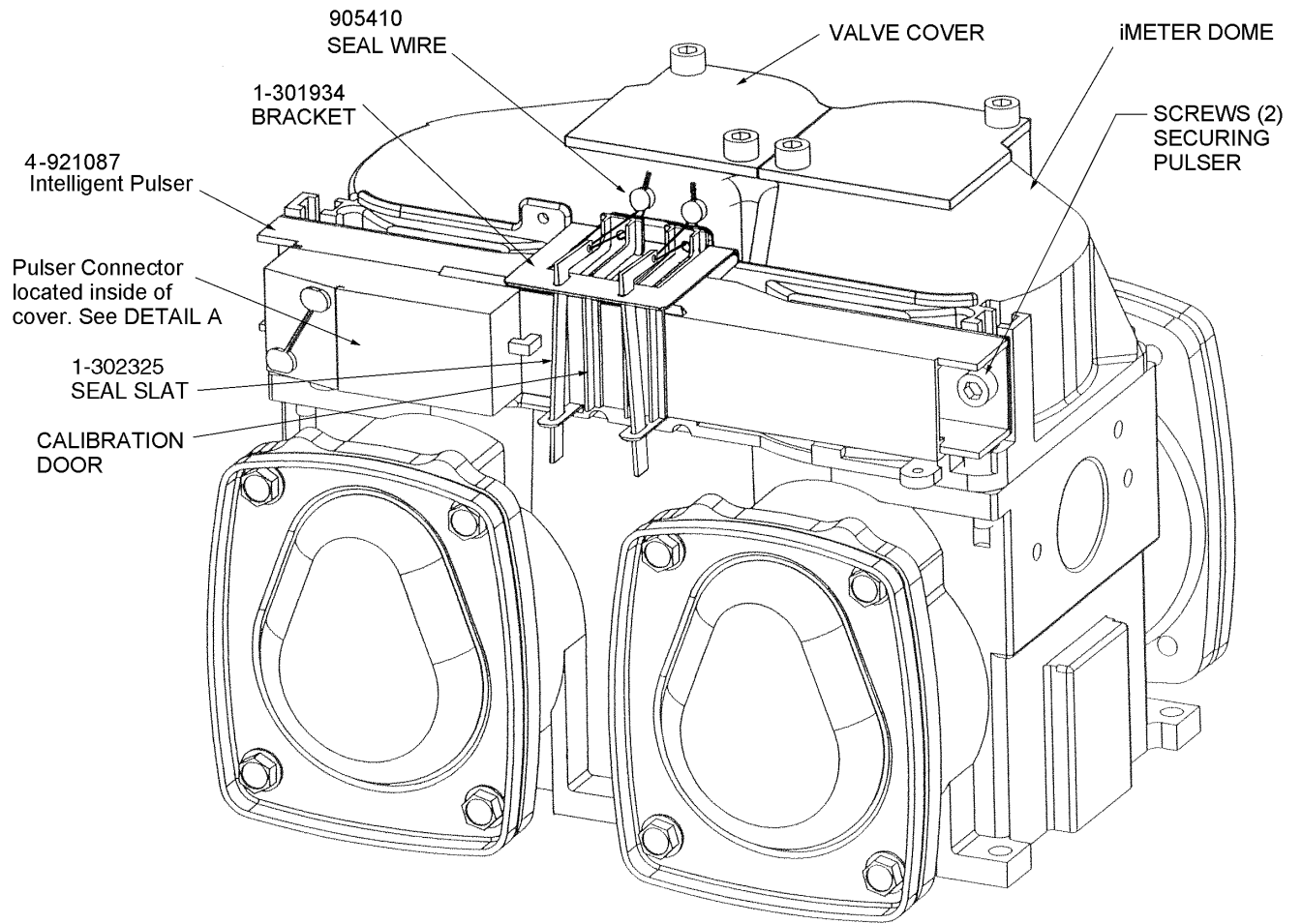

**FIGURE 10-1 IMETER AND INTELLIGENT PULSER.**

 **WARNING**

**Before removing any components, as discussed in the following sections, in the hydraulics cabinet or in the hydraulic system of the dispenser, you should trip the impact valve and remove power to the submersible pump for the product(s) in question to prevent fuel spills. Failure to do so could cause a fire hazard that may result in serious injury or death.**

 **WARNING**

**Drain the fuel into an appropriate container and pour it into an underground tank to prevent fuel drainage under and around the dispenser. Failure to do so could cause a fire hazard that may result in serious injury or death.**

### 10.11 PROPORTIONAL VALVE ASSEMBLY REPLACEMENT

The valve and coil are not separately replaceable. The valve, coil, wiring and potted conduit are replaced as an assembly. See Figures 5-2 through 5-5.

Adhere to the above **Warnings!**, and then:

1. Power down the dispenser at J3 on relay board.
2. Disconnect valve wires at J3 on computer board.
3. Loosen under the head and inside the head, the locknuts on the valve conduit.
4. Remove the (2) screws that secure the retaining plate to the meter outlet and remove retaining plate.
5. Remove the retaining (safety) clip that secures the product tube to the valve.
6. Pull the valve out from the meter and remove the valve and conduit assembly. If necessary to gain clearance, first remove 5/16" nut on coil and remove coil.
7. Replace with new assembly in reverse order.

## 10.12 iMETER REPLACEMENT

After adhering to the **Warnings!** on the previous page, removing power to the dispenser and submersible pump, and tripping the impact valve, perform the following for both sides of the meter:

1. Remove the nozzle boots and brackets as necessary to gain access to the iMeter assembly.  
  
For reference during this procedure, see Figures 10-1, 10-2 and previous figures in Section 5.
2. Cut and remove the seal wires and remove the slats and bracket from the pulser.
3. Loosen (2) screws that secure the pulser to the imeter assembly; remove pulser from meter and set aside on top of adjacent meter; it may not be necessary to disconnect the pulser cable.
4. Disconnect valve wires from J3 on the computer board.
5. Loosen under the head and remove inside the head, the locknut(s) on the valve conduit.
6. Remove (2) screws that secure the retaining plate to meter outlet; raise and then remove plate.
7. Remove the (safety) clip that secures the product tube to the valve and disconnect the product tube from the valve.
8. Pull the valve out from the meter and set the valve and conduit assembly aside.
9. Remove (6) Allen head metric screws that secure the imeter assembly to the strainer casting.
10. Remove the imeter assembly.
11. Install new o-rings in the grooves on strainer casting, applying a white lithium grease or Vaseline in the o-ring grooves. Note: The grease, in addition to a lubricant, acts as an adhesive to help keep the o-rings seated in the grooves when turning the assembly back over.
12. Install new imeter assembly and secure to strainer casting with (6) screws removed in step 9. Note: Do not pinch the o-rings. Do not over tighten screws. If meter leaks, remove and replace o-rings. If screws are tightened to stop leak, threads in the strainer casting will be damaged.
13. Re-install valve assembly and retaining plate. Be sure to seat the retaining plate, easily, into groove on valve to ensure not to pinch the o-ring. Secure retaining plate with (2) screws removed in step 6.
14. Insert product tube into valve and insert the safety clip to secure the product tube to the valve.
15. Re-install pulser and bracket on the new imeter assembly and reconnect cable if disconnected.
16. Re-secure both locknuts on the valve conduit and reconnect valve wires to computer board.
17. Re-install the nozzle boot brackets and nozzle boots.
18. Return dispenser to normal operation and check for leaks.
19. Follow instructions in Section 10.9.1 on pulser mode setting and iMeter calibration.

### 10.13 CHECK VALVE REPLACEMENT

There are two check and pressure relief valves in the imeter module (one for each meter). The valves are located at the top of the meter, in the meter dome, under removable cover plates.

The check and pressure relief valve is a non-serviceable part. Failure symptoms are computer jump and crossflow. If a valve fails, replace it as follows.

1. Remove the (2) screws that secure the valve cover to the meter dome and remove the valve cover.
2. Remove the check valve (and o-ring) from the meter. Discard the o-ring.
3. Install new valve and new o-ring.  
Note: Seat valve fully by hand before re-installing the valve cover.  
Do not pinch the o-ring against the meter.
4. Re-install the valve cover with the (2) screws removed step 1.

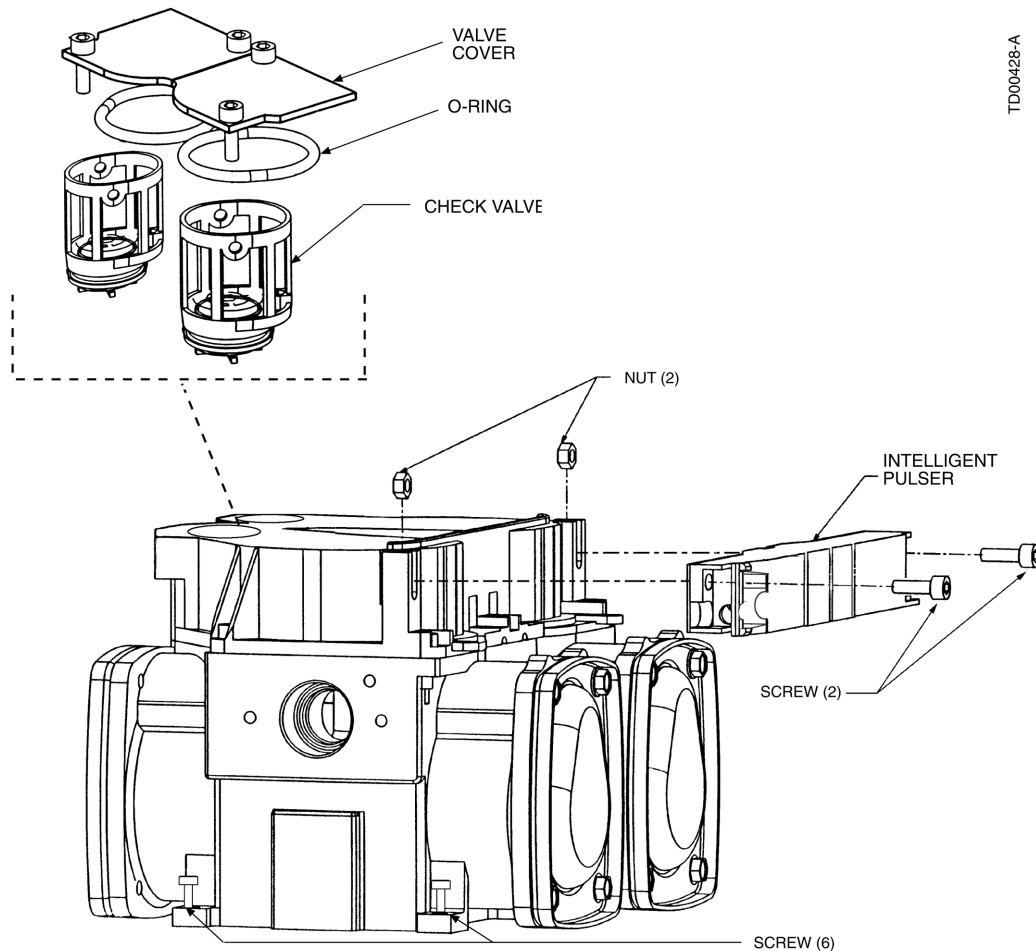

**FIGURE 10-2 iMETER MODULE SERVICEABLE PARTS.** *The replaceable parts on the iMeter module are the pulser, check valves, o-rings and valve covers.*

## **11. PRESET PROGRAMMING**

The 3/Vista dispenser preset option can provide either an accumulating key entry or a scrolling key entry and it can use either the preset display or the sale display simply by changing the programming in function 24. Another feature is every button on the keypad is a softkey. No buttons have a hard coded value or function. All softkeys are programmable via function 25.

Function 24 and 25 are defined as follows:

### 24.00 Preset Operation

- 1 = Money only
- 2 = Volume only
- 3 = Default to money
- 4 = Default to volume

### 24.01 Preset entry required before filling

- 1 = preset required
- 2 = preset not required

### 24.02 Fill mode display

- 1 = display “-----” when fill key pressed
- 2 = display “FILL” when fill key pressed

### 24.03 Preset mode display

- 1 = Display “ ” on sale display during preset
- 2 = Display “-----” on sale display during preset
- 3 = Display “Preset” on sale display during preset

### 24.04 Preset entry timeout

- 0 (disabled) to 60 seconds

### 24.05 Preset entry operation

- 0 = Accumulate preset key entries
- 1 = Scroll preset key entries

### 24.06 First digit entry point for money

- 1 through 6, digit 1 is the left most digit

### 24.07 First digit entry point for volume

- 1 through 6, digit 1 is the left most digit

### 24.08 Sale display option

- 0 = Use preset keypad display
- 1 = Use sale display to indicate preset

## 11. PRESET PROGRAMMING, continued

25.01 through 25.32 Soft Keys

These can contain any of the possible values below:

- 0 = Disabled
- 1 = select softkey value #1
- 2 = select softkey value #2
- 3 = select softkey value #3
- 4 = select softkey value #4
- 5 = select softkey value #5
- 6 = select softkey value #6
- 7 = select softkey value #7
- 8 = select softkey value #8
- 9 = select softkey value #9
- 10 = select softkey value #10
- 11 = select money
- 12 = select volume
- 13 = toggle
- 14 = select FILL
- 15 = clear key
- 16 = enter key

25.33 soft key value #1  
value 0 through 999999

25.34 soft key value #2  
value 0 through 999999

25.35 soft key value #3  
value 0 through 999999

25.36 soft key value #4  
value 0 through 999999

25.37 soft key value #5  
value 0 through 999999

25.38 soft key value #6  
value 0 through 999999

25.39 soft key value #7  
value 0 through 999999

25.40 soft key value #8  
value 0 through 999999

25.41 soft key value #9  
value 0 through 999999

25.42 soft key value #10  
value 0 through 999999



## 11. PRESET PROGRAMMING, continued

*Twelve button keyboard. This is the 3/Vista keypad. The purpose of this keyboard is to enter any preset value.*

### *physical button assignment*

|                  | Row 1<br>J4:1    | Row 2<br>J4:2     |
|------------------|------------------|-------------------|
| Column 1<br>J4:4 | Softkey 1<br>“1” | Softkey 9<br>“2”  |
| Column 2<br>J4:5 | Softkey 2<br>“3” | Softkey 10<br>“4” |
| Column 3<br>J4:6 | Softkey 3<br>“5” | Softkey 11<br>“6” |
| Column 4<br>J4:7 | Softkey 4<br>“7” | Softkey 12<br>“8” |
| Column 5<br>J4:8 | Softkey 5<br>“9” | Softkey 13<br>“0” |
| Column 6<br>J4:9 | Softkey 6<br>“E” | Softkey 14<br>“C” |

### **Preset Operation**

The Preset Mode default *money* or *volume* depends on the option programming

In principle, the operator has to:

- select money or volume preset entry (if this function is assigned),
- enter the preset value
- lift nozzle to start the filling.

### ***Preset Entry Example:***

Pump Display shows last sale

Operator presses a digit key.

The display starts to blink

If this is a numeric key the number will be indicated at the default panel (volume or money panel), the other panel shows the selection made in function 24.03.

If this is the M/V key, the display will switch to the Money/Volume line, in case of money selected, function 24.03 selection is indicated on the volume panel.

Pressing the “C” key cancels the preset operation.

Display will continue to blink showing the entered numbers at one panel and function 24.03 selection at the other until the operator lifts the nozzle or a timeout occurs.

The display starts the reset cycle and stop blinking.

The normal filling information will be indicated at the display.

At the end of the sale the display shows the sale.

## **11. PRESET PROGRAMMING, continued**

### ***Preset functionality:***

Function 24 could be programmed as follows for this keypad.

- 24.00 Preset Operation = 1 (Money only)
- 24.01 Preset entry required before filling = 2 (preset not required)
- 24.02 Fill mode display = 2 display "FILL" when fill key pressed
- 24.03 Preset mode display = 3 (Display "Preset" on sale display during preset)
- 24.04 Preset entry timeout = 50 seconds
- 24.05 Preset entry operation = 1 (Scroll preset key entries)
- 24.06 First digit entry point for money = 3
- 24.07 First digit entry point for volume = 4
- 24.08 Sale display option = 1 (Use sale display to indicate preset)

### ***Functionality of the buttons:***

Function 25 could be programmed as follows for this keypad

#### Softkeys

- 25.01 = 1 (softkey value #1)
- 25.02 = 3 (softkey value #3)
- 25.03 = 5 (softkey value #5)
- 25.04 = 7 (softkey value #7)
- 25.05 = 9 (softkey value #9)
- 25.06 = 16 (enter key)
- 25.07 = 0 (disabled)
- 25.08 = 0 (disabled)
- 25.09 = 2 (softkey value #2)
- 25.10 = 4 (softkey value #4)
- 25.11 = 6 (softkey value #6)
- 25.12 = 8 (softkey value #8)
- 25.13 = 10 (softkey value #10)
- 25.14 = 15 (clear key)
- 25.15 through 25.32 = 0

#### Softkey values

- 25.33 = 1
- 25.34 = 2
- 25.35 = 3
- 25.36 = 4
- 25.37 = 5
- 25.38 = 6
- 25.39 = 7
- 25.40 = 8
- 25.41 = 9
- 25.42 = 0

## 11. PRESET PROGRAMMING, continued

### *Five button keyboard*

The preset options can also be configured to support the five button preset.

### *physical button assignment*

|       |           |
|-------|-----------|
|       |           |
| Col 1 | Softkey 1 |
| Col 2 | Softkey 2 |
| Col 3 | Softkey 3 |
| Col 4 | Softkey 4 |
| Col 5 | Softkey 5 |

It is possible to assign three different preset values (softkey value #1, #2, #3) to softkeys 1-3. Softkey 4 could be used as a fourth value or to toggle between Money and Volume preset. Button 5, could be used for the Clear function.

### **Preset Operation**

Pressing a button indicates the assigned preset value on the amount or volume panel.

If the function "Toggle between Money or volume" is assigned to one softkey, it is possible to switch between money or volume preset.

Each press of the buttons increments (accumulates) the preset value.

Example of operation:

You have 4 fixed values of 1, 5, 10, and 25.

Multiple press of any of the fixed preset value buttons will be added to the preset value.

For example, if you press the button 10, 10 will be indicated,

next you press 10, then 20 (10+10) will be indicated,

next you press 1, then 21 will be indicated as preset value at the display.

Pressing CLEAR will reset the Preset entry.

Any press (before nozzle lift) will be added to the previous value.

The function programming for this example would be as follows:

24.00 Preset Operation = 1 (Money only)

24.01 Preset entry required before filling = 2 (preset not required)

24.02 Fill mode display = 2 (display "FILL" when fill key pressed)

24.03 Preset mode display = 3 (Display "Preset" on sale display during preset)

24.04 Preset entry timeout = 50 seconds

24.05 Preset entry operation = 0 (Accumulate preset key entries)

24.06 First digit entry point for money = 3

24.07 First digit entry point for volume = 4

24.08 Sale display option = 1 (Use sale display to indicate preset)

## **11. PRESET PROGRAMMING, continued**

Function 25 could be programmed as follows for this keypad

Softkeys

25.01 = 1 (softkey value #1)

25.02 = 2 (softkey value #2)

25.03 = 3 (softkey value #3)

25.04 = 4 (softkey value #4)

25.05 = 15 (clear key)

25.06 through 25.32 = 0 (disabled)

25.33 soft key value #1 = 1

25.34 soft key value #2 = 5

25.35 soft key value #3 = 10

25.36 soft key value #4 = 25

25.37 through 25.42 = 0

## 12. WIRING DIAGRAMS

Dispenser wiring diagrams are contained in this section in the following order:

| <u>Model Number</u>      | <u>Drawing Number</u> |
|--------------------------|-----------------------|
| 3/V390D                  | 1-6632-D              |
| 3/V390D/U                | 2-6632-D              |
| 3/V387D                  | 3-6632-D              |
| 3/V490D                  | 4-6632-D              |
| 3/V580D, 3/V585D         | 5-6632-D              |
| 3/V590D/U, 3/V595D/U     | 5-6632-D              |
| 3/V389D, 3/V399D         | 6-6632-D              |
| 3/V590D                  | 7-6632-D              |
| 3/V591D                  | 8-6632-D              |
| 3/V595D, 3/V595D// A     | 9-6632-D              |
| 3/V490D/U                | 10-6632-D             |
| 3/V388D                  | 11-6632-D             |
| 3/V390P/U                | 12-6632-D             |
| 3/V580P, 3/V585P         | 13-6632-D             |
| 3/V590P/U, 3/V595P/U     | 13-6632-D             |
| 3/V390P                  | 14-6632-D             |
| 3/V389P, 3/V399P         | 15-6632-D             |
| 3/V387P                  | 16-6632-D             |
| 3/V595P                  | 19-6632-D             |
| 3/V390P/U/G              | (3Ph) 20-6632-D       |
| 3/V580P// G, 3/V585P// G | (3Ph) 21-6632-D       |
| 3/V590P/U/G, 3/V595P/U/G | (3Ph) 21-6632-D       |
| 3/V390P//G               | (3Ph) 22-6632-D       |
| 3/V389P//G, 3/V399P//G   | (3Ph) 23-6632-D       |
| 3/V387P//G               | (3Ph) 24-6632-D       |
| 3/V595P//G               | (3Ph) 27-6632-D       |
| 3/V388P//G               | (3Ph) 28-6632-D       |
| 3/V388P                  | (3Ph) 29-6632-D       |

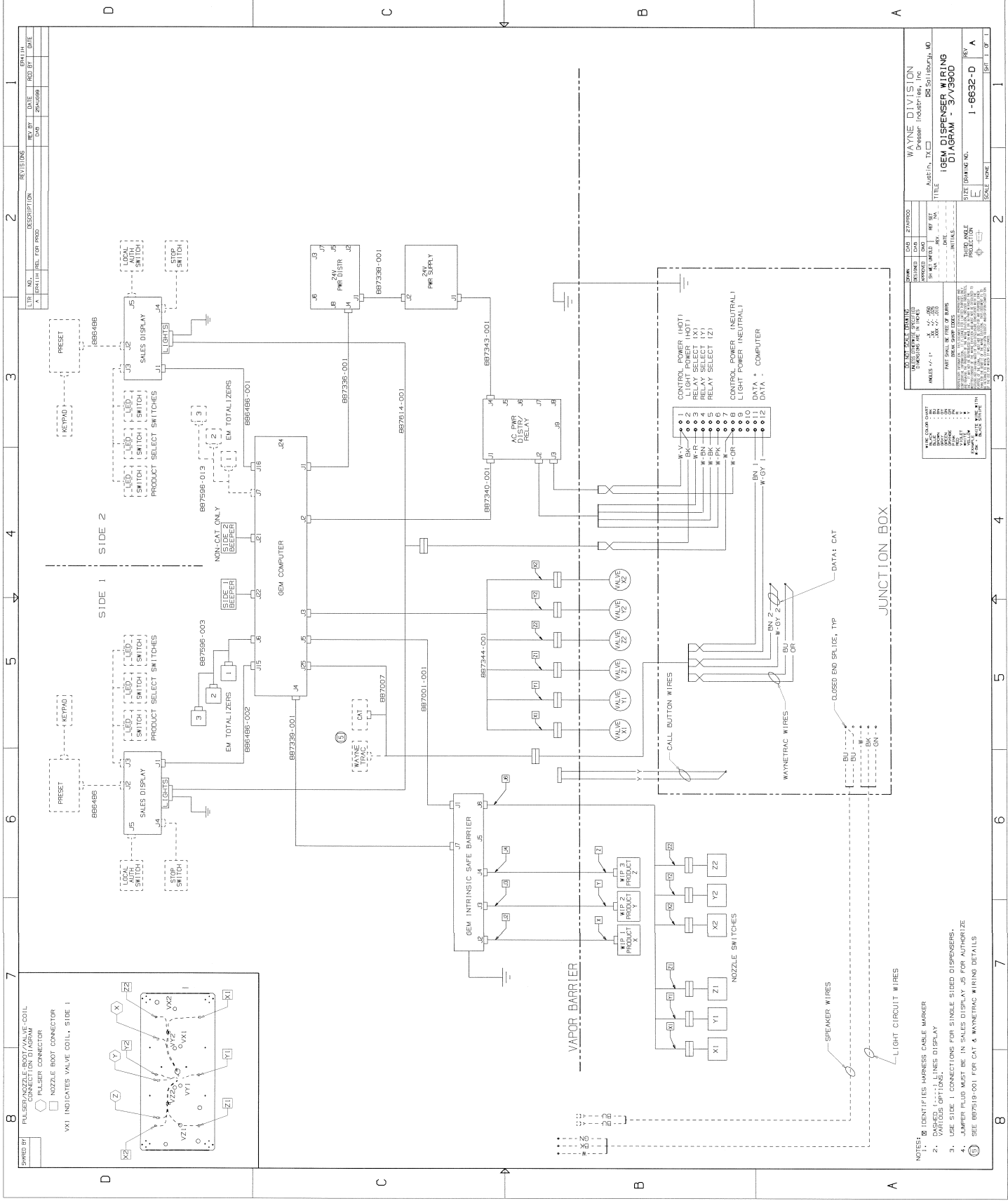

REVISED BY: [ ] DATE: [ ]

DESCRIPTION: [ ]

REVISED BY: [ ] DATE: [ ]

DESCRIPTION: [ ]

DATE: [ ] TIME: [ ]

BY: [ ]

FOR: [ ]

FROM: [ ]

DATE: [ ] TIME: [ ]

BY: [ ]

FOR: [ ]

FROM: [ ]

DATE: [ ] TIME: [ ]

BY: [ ]

FOR: [ ]

FROM: [ ]

DATE: [ ] TIME: [ ]

BY: [ ]

FOR: [ ]

FROM: [ ]

DATE: [ ] TIME: [ ]

BY: [ ]

FOR: [ ]

FROM: [ ]

DATE: [ ] TIME: [ ]

BY: [ ]

FOR: [ ]

FROM: [ ]

WAYNE DIVISION  
Dresser Industries, Inc.  
AUSTIN, TX

TITLE: 16EM DISPENSER WIRING DIAGRAM - 3/19/90

SCALE: NONE

REV: A

1-6632-D

WAVELENGTH MARKER  
DASHED (---) LINES DISPLAY  
WIRING OPTIONS.

3. USE SIDE 1 CONNECTIONS FOR SINGLE SIDED DISPENSERS.

4. JUMPER PLUG MUST BE IN SALES DISPLAY J5 FOR AUTHORIZED SEE BB751B-001 FOR CAT & WAYMETRIC WIRING DETAILS

NOTES:  
 1. IDENTIFIERS: HARNESS CABLE MARKER  
 2. WIRING OPTIONS.  
 3. USE SIDE 1 CONNECTIONS FOR SINGLE SIDED DISPENSERS.  
 4. JUMPER PLUG MUST BE IN SALES DISPLAY J5 FOR AUTHORIZED SEE BB751B-001 FOR CAT & WAYMETRIC WIRING DETAILS

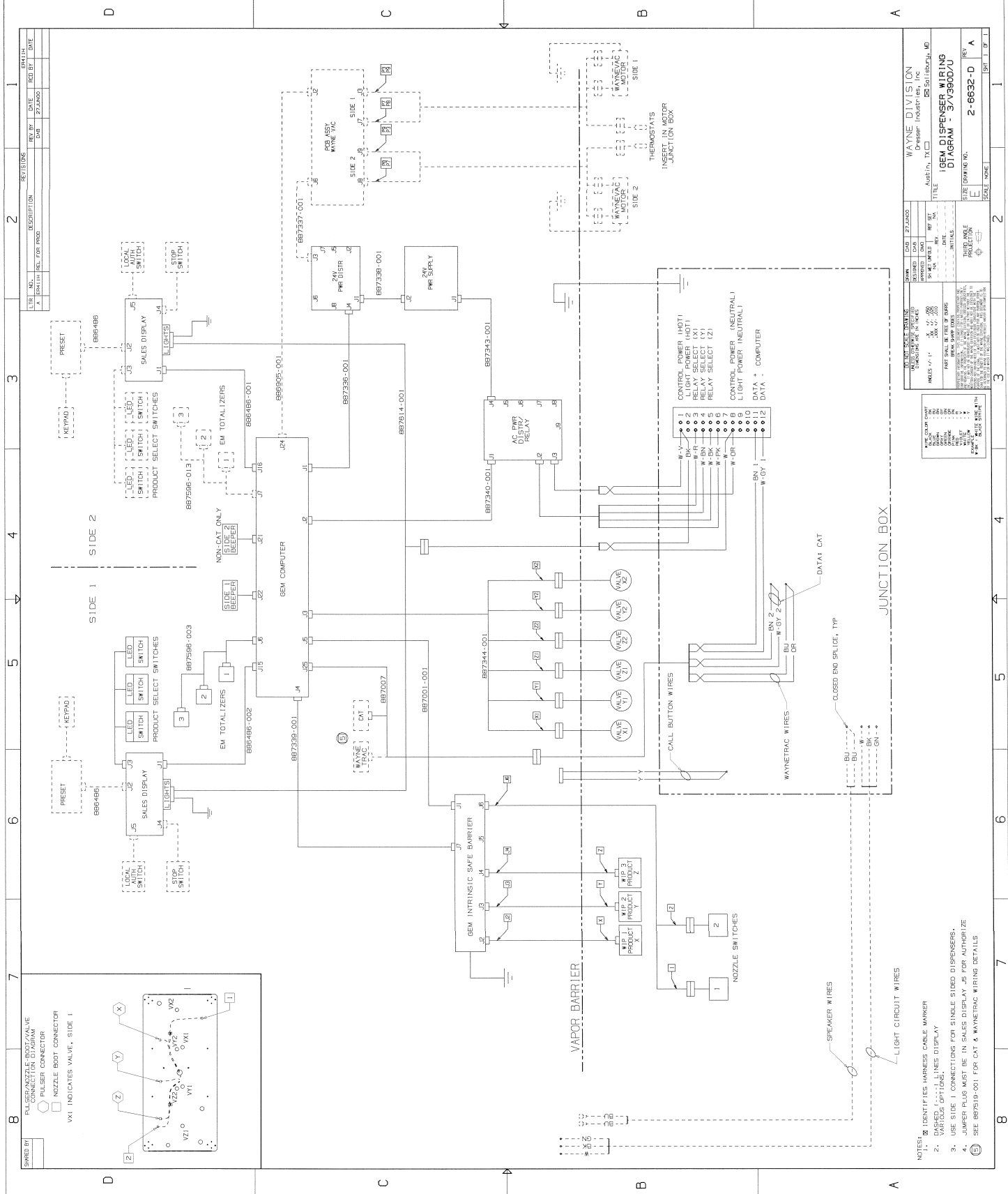

| REVISIONS |                       | DATE |      | BY |    |
|-----------|-----------------------|------|------|----|----|
| NO.       | DESCRIPTION           | DATE | DATE | BY | BY |
| 1         | ISSUED FOR PRODUCTION |      |      |    |    |

|         |    |                       |
|---------|----|-----------------------|
| DATE    | BY | DESCRIPTION           |
| 10/1/88 | JM | ISSUED FOR PRODUCTION |

|         |    |                       |
|---------|----|-----------------------|
| DATE    | BY | DESCRIPTION           |
| 10/1/88 | JM | ISSUED FOR PRODUCTION |

|         |    |                       |
|---------|----|-----------------------|
| DATE    | BY | DESCRIPTION           |
| 10/1/88 | JM | ISSUED FOR PRODUCTION |

|         |    |                       |
|---------|----|-----------------------|
| DATE    | BY | DESCRIPTION           |
| 10/1/88 | JM | ISSUED FOR PRODUCTION |

|         |    |                       |
|---------|----|-----------------------|
| DATE    | BY | DESCRIPTION           |
| 10/1/88 | JM | ISSUED FOR PRODUCTION |

|         |    |                       |
|---------|----|-----------------------|
| DATE    | BY | DESCRIPTION           |
| 10/1/88 | JM | ISSUED FOR PRODUCTION |

|         |    |                       |
|---------|----|-----------------------|
| DATE    | BY | DESCRIPTION           |
| 10/1/88 | JM | ISSUED FOR PRODUCTION |

|         |    |                       |
|---------|----|-----------------------|
| DATE    | BY | DESCRIPTION           |
| 10/1/88 | JM | ISSUED FOR PRODUCTION |

NOTES:  
 1. \* IDENTIFIES HARNESS CABLE MARKER  
 2. DASHED POTENTIALS DISPLAY  
 3. USE SIDE 1 CONNECTIONS FOR SINGLE STROKED DISPENSERS.  
 4. JUMPER PLUG MUST BE IN SALES DISPLAY AS FOR AUTHORIZED  
 SEE 887519-001 FOR CAT & WYMETRIC WIRING DETAILS

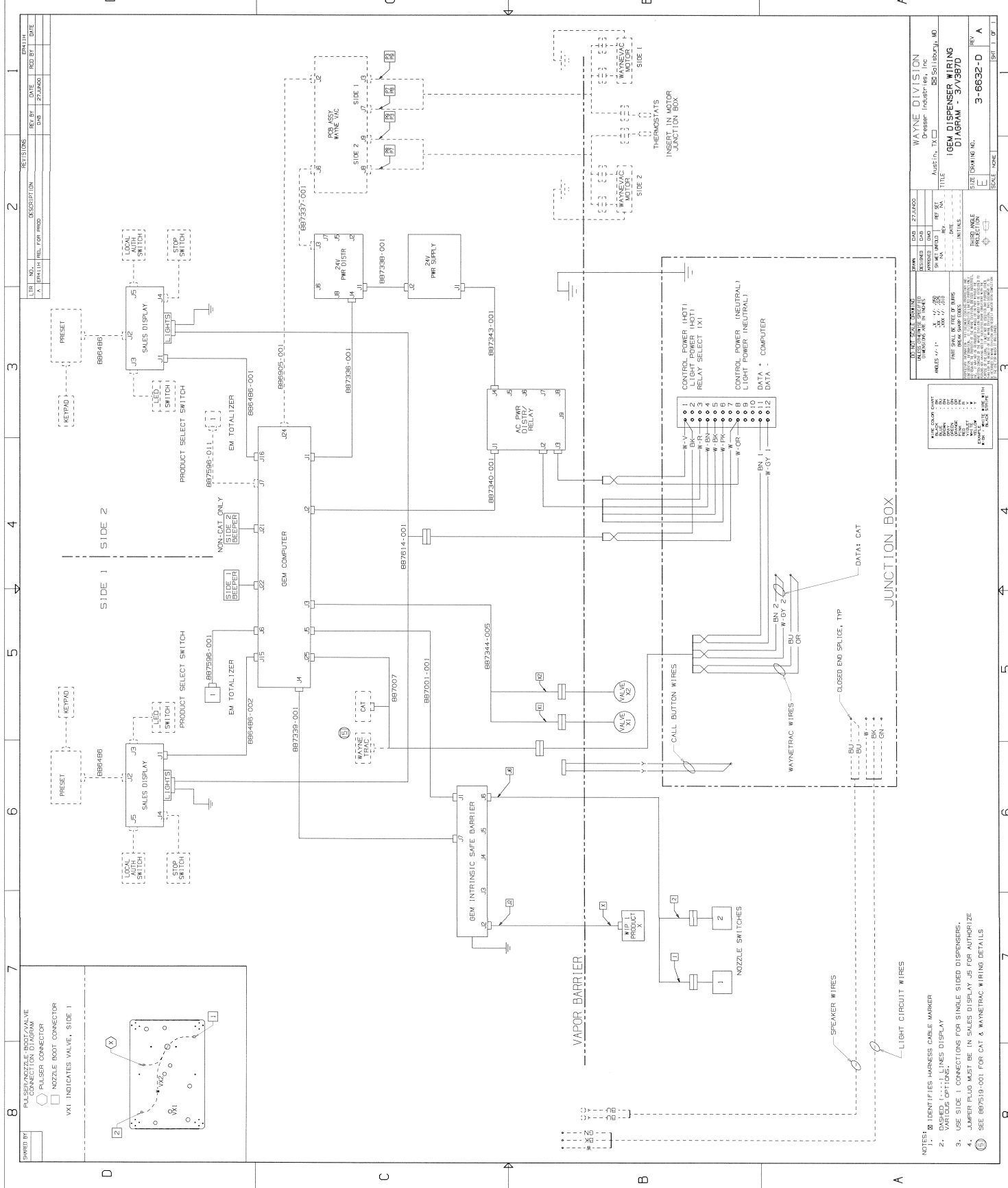

| LIB. NO. | REV. NO. | DESCRIPTION | REV. BY | DATE    | REV. DATE | REV. DATE |
|----------|----------|-------------|---------|---------|-----------|-----------|
| A        | 1        | REVISION    | DAB     | 27JAN00 |           |           |

|   |  |  |
|---|--|--|
| <b>WAYNE DIVISION</b><br>Dresser Industries, Inc.<br>Houston, TX<br>85 SHELTON RD<br>TITLE: I8EM DISPENSER WIRING DIAGRAM - 3/3/87D<br>SIZE: 8 1/2" X 11" |  | DOW 27JAN00<br>APPROVED: [Signature]<br>SH. NO. 1<br>REF. NO. 1<br>DATE: 27JAN00<br>INITIALS: [Initials] |
| SCALE: NONE<br>SHEET: 1 OF 1  |  | THIRD WIRE<br>CONNECTION<br>SEE 887519-001 FOR DAT & WAYMETRIC WIRING DETAILS                            |

- NOTES:
- IDENTIFIES HARNESS CABLE MARKER
  - DASHED (---) LINES DISPLAY VARIOUS OPTIONS.
  - USE SIDE 1 CONNECTIONS FOR SINGLE SIDED DISPENSERS.
  - JUMPER PLUG MUST BE IN SALES DISPLAY J5 FOR AUTHORITY
  - SEE 887519-001 FOR DAT & WAYMETRIC WIRING DETAILS



|                       |  |          |    |          |       |              |      |
|-----------------------|--|----------|----|----------|-------|--------------|------|
| WAYNE DIVISION        |  | DATE     | BY | REV.     | DATE  | BY           | REV. |
| AUBREY, TX            |  | 01/80    | SS | 1        | 01/80 | SS           | 1    |
| TITLE                 |  | PART NO. |    | REV. SET |       | REV. SET     |      |
| IGEM DISPENSER WIRING |  | 4-6632-D |    | E        |       | A            |      |
| DIAGRAM - S/M4800     |  | SCALE    |    | NONE     |       | SHEET 1 OF 1 |      |

|       |    |      |       |    |      |
|-------|----|------|-------|----|------|
| DATE  | BY | REV. | DATE  | BY | REV. |
| 01/80 | SS | 1    | 01/80 | SS | 1    |

WIRING DIAGRAMS  
 DRAWING NO. 4-6632-D  
 PART NO. S/M4800  
 TITLE IGEM DISPENSER WIRING  
 SCALE NONE  
 SHEET 1 OF 1

NOTES:  
 1. IDENTIFIES HARNESS CABLE MARKER  
 2. DASHED LINES DISPLAY  
 3. USE SIDE 1 CONNECTIONS FOR SINGLE SIDED DISPENSERS.  
 4. JUMPER PLUG MUST BE IN SALES DISPLAY JS FOR AUTHORIZED  
 SEE BB7518-001 FOR CAT & WAYNETRAC WIRING DETAILS

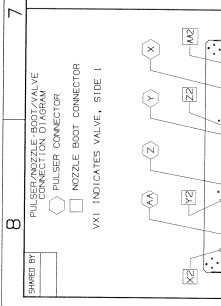
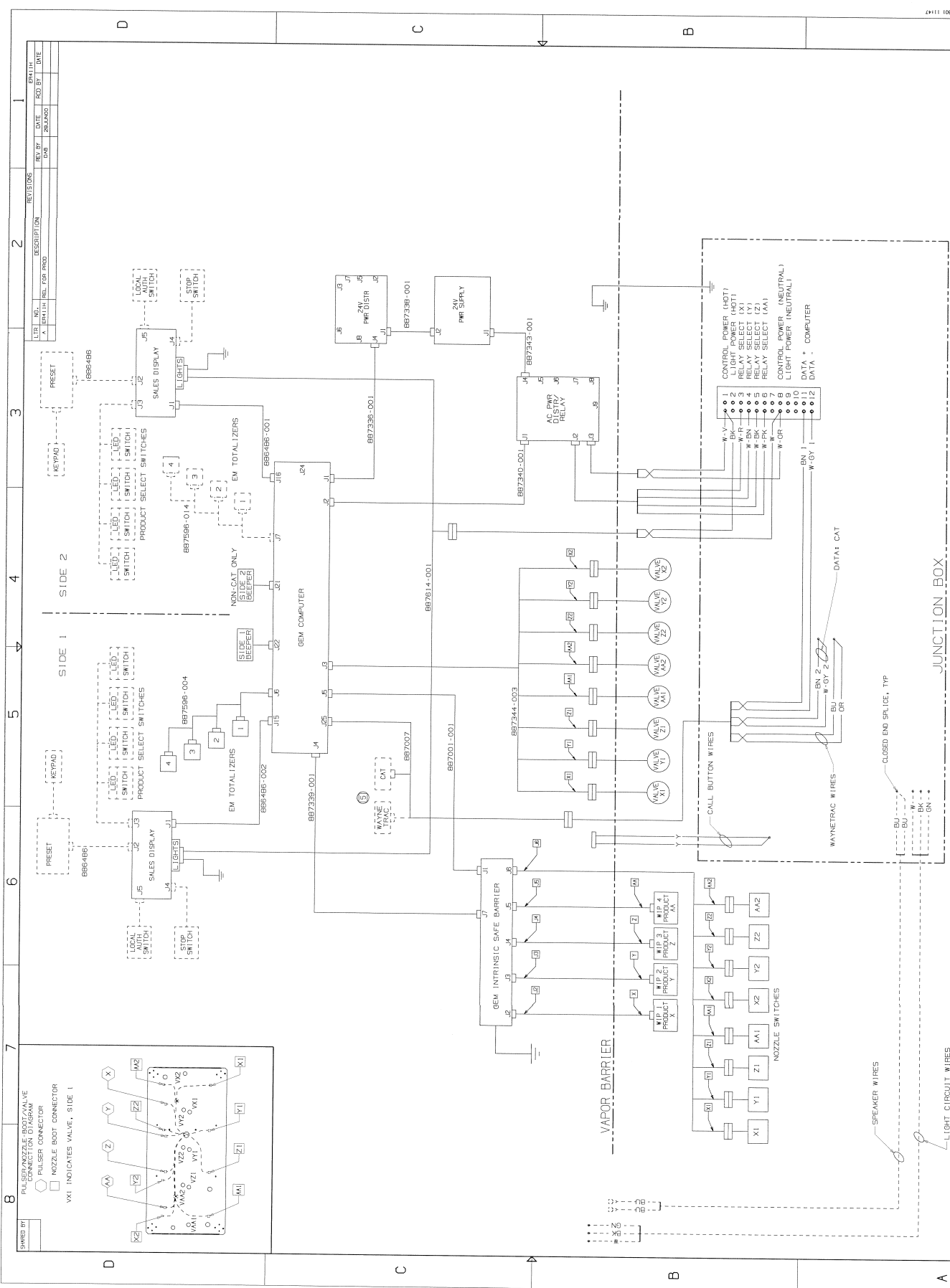

WIRING DIAGRAMS  
 DRAWING NO. 4-6632-D  
 PART NO. S/M4800  
 TITLE IGEM DISPENSER WIRING  
 SCALE NONE  
 SHEET 1 OF 1

NOTES:  
 1. IDENTIFIES HARNESS CABLE MARKER  
 2. DASHED LINES DISPLAY  
 3. USE SIDE 1 CONNECTIONS FOR SINGLE SIDED DISPENSERS.  
 4. JUMPER PLUG MUST BE IN SALES DISPLAY JS FOR AUTHORIZED  
 SEE BB7518-001 FOR CAT & WAYNETRAC WIRING DETAILS



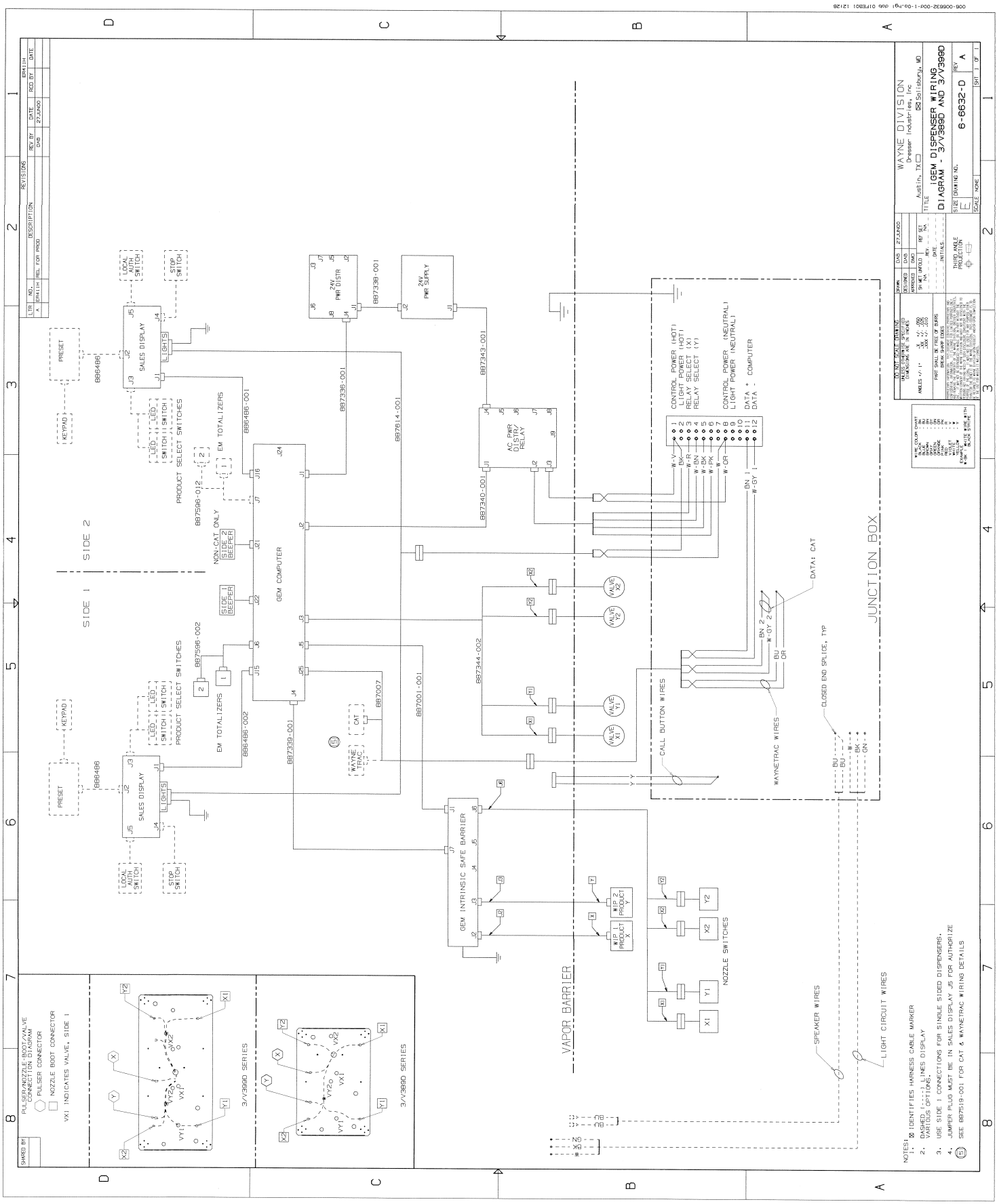

| REV | NO. | DATE      | BY  | CHKD BY | DATE | DESCRIPTION | REVISIONS | DATE | BY  |
|-----|-----|-----------|-----|---------|------|-------------|-----------|------|-----|
| A   | 1   | 27 JUN 60 | ... | ...     | ...  | ...         | ...       | ...  | ... |

| REV | NO. | DATE      | BY  | CHKD BY | DATE | DESCRIPTION | REVISIONS | DATE | BY  |
|-----|-----|-----------|-----|---------|------|-------------|-----------|------|-----|
| A   | 1   | 27 JUN 60 | ... | ...     | ...  | ...         | ...       | ...  | ... |

| REV | NO. | DATE      | BY  | CHKD BY | DATE | DESCRIPTION | REVISIONS | DATE | BY  |
|-----|-----|-----------|-----|---------|------|-------------|-----------|------|-----|
| A   | 1   | 27 JUN 60 | ... | ...     | ...  | ...         | ...       | ...  | ... |

| REV | NO. | DATE      | BY  | CHKD BY | DATE | DESCRIPTION | REVISIONS | DATE | BY  |
|-----|-----|-----------|-----|---------|------|-------------|-----------|------|-----|
| A   | 1   | 27 JUN 60 | ... | ...     | ...  | ...         | ...       | ...  | ... |

| REV | NO. | DATE      | BY  | CHKD BY | DATE | DESCRIPTION | REVISIONS | DATE | BY  |
|-----|-----|-----------|-----|---------|------|-------------|-----------|------|-----|
| A   | 1   | 27 JUN 60 | ... | ...     | ...  | ...         | ...       | ...  | ... |

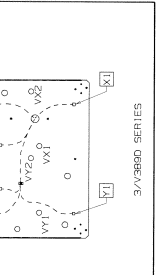
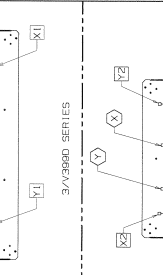
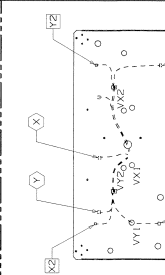
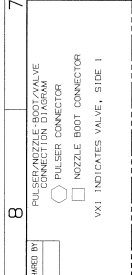

| REV | NO. | DATE      | BY  | CHKD BY | DATE | DESCRIPTION | REVISIONS | DATE | BY  |
|-----|-----|-----------|-----|---------|------|-------------|-----------|------|-----|
| A   | 1   | 27 JUN 60 | ... | ...     | ...  | ...         | ...       | ...  | ... |

| REV | NO. | DATE      | BY  | CHKD BY | DATE | DESCRIPTION | REVISIONS | DATE | BY  |
|-----|-----|-----------|-----|---------|------|-------------|-----------|------|-----|
| A   | 1   | 27 JUN 60 | ... | ...     | ...  | ...         | ...       | ...  | ... |

| REV | NO. | DATE      | BY  | CHKD BY | DATE | DESCRIPTION | REVISIONS | DATE | BY  |
|-----|-----|-----------|-----|---------|------|-------------|-----------|------|-----|
| A   | 1   | 27 JUN 60 | ... | ...     | ...  | ...         | ...       | ...  | ... |

SHOWN BY:  
 PULSED CONNECTION BY VAPOR VALVE  
 ○ PULSER CONNECTOR  
 □ NOZZLE BOOT CONNECTOR  
 Vx1 INDICATES VALVE, SIDE 1

NOTES:  
 1. X1 IDENTIFIES HARNESS CABLE MARKER  
 2. VARIOUS OPTIONS  
 3. USE SIDE 1 CONNECTIONS FOR SINGLE SIDED DISPENSERS.  
 4. JUMPER PLUS MUST BE IN SALES DISPLAY J5 FOR AUTHORIZED  
 5. SEE BB7319-001 FOR CAT & WAYNETRAC WIRING DETAILS

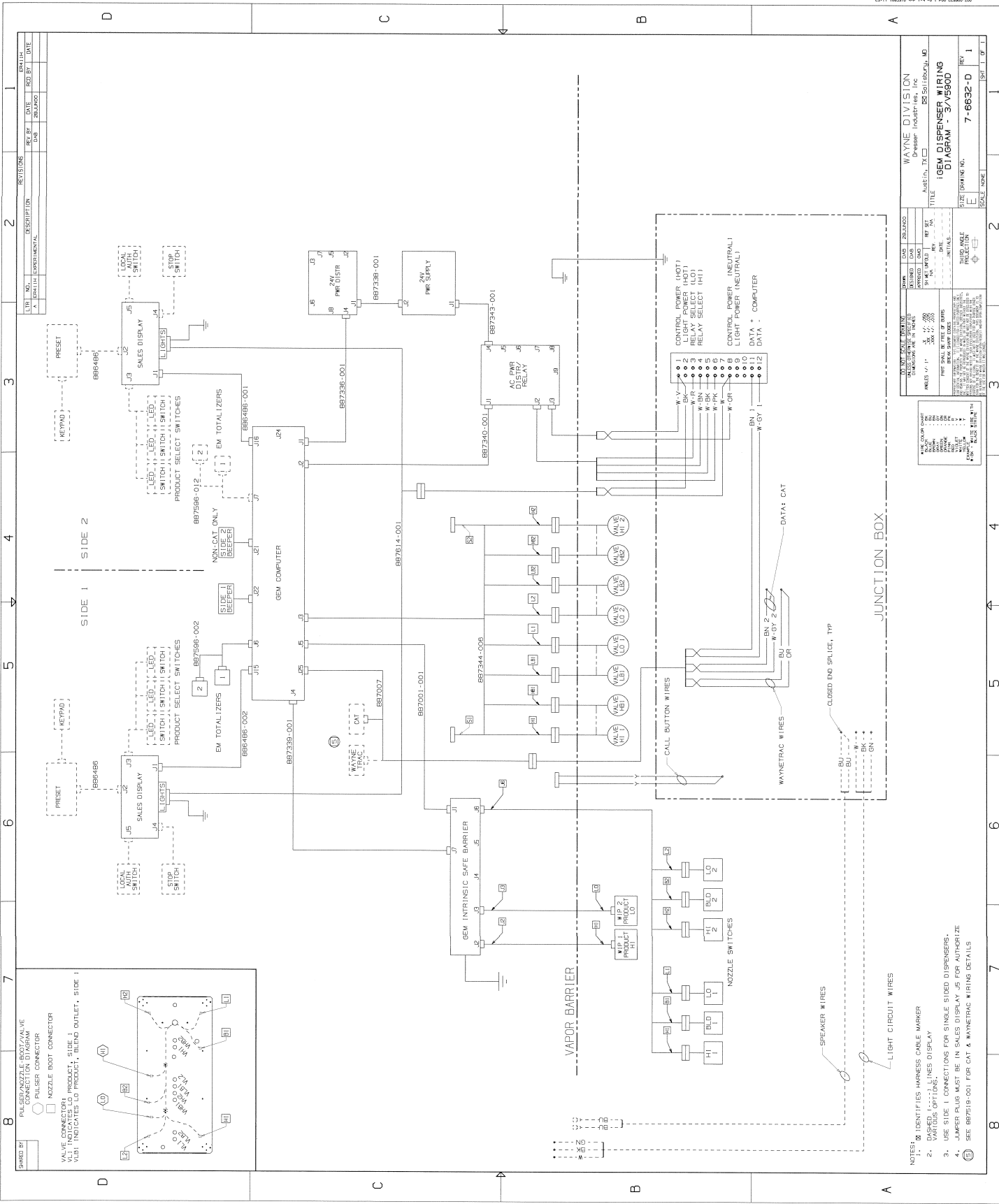

| REV | DATE     | BY | CHK |
|-----|----------|----|-----|
| 1   | 08/20/07 | WJ | WJ  |

| REV | DATE     | BY | CHK |
|-----|----------|----|-----|
| 1   | 08/20/07 | WJ | WJ  |

| REV | DATE     | BY | CHK |
|-----|----------|----|-----|
| 1   | 08/20/07 | WJ | WJ  |

| REV | DATE     | BY | CHK |
|-----|----------|----|-----|
| 1   | 08/20/07 | WJ | WJ  |

| REV | DATE     | BY | CHK |
|-----|----------|----|-----|
| 1   | 08/20/07 | WJ | WJ  |

| REV | DATE     | BY | CHK |
|-----|----------|----|-----|
| 1   | 08/20/07 | WJ | WJ  |

| REV | DATE     | BY | CHK |
|-----|----------|----|-----|
| 1   | 08/20/07 | WJ | WJ  |

| REV | DATE     | BY | CHK |
|-----|----------|----|-----|
| 1   | 08/20/07 | WJ | WJ  |

NOTES:  
 1. IDENTIFIES HARNESS CABLE MARKER  
 2. VARIOUS OPTIONS  
 3. USE SIDE 1 CONNECTIONS FOR SINGLE SIDED DISPENSERS.  
 4. JUMPER PLUG MUST BE IN SALES DISPLAY J5 FOR AUTHORIZED  
 SEE BB7519-001 FOR CAT & WAYMETRAC WIRING DETAILS





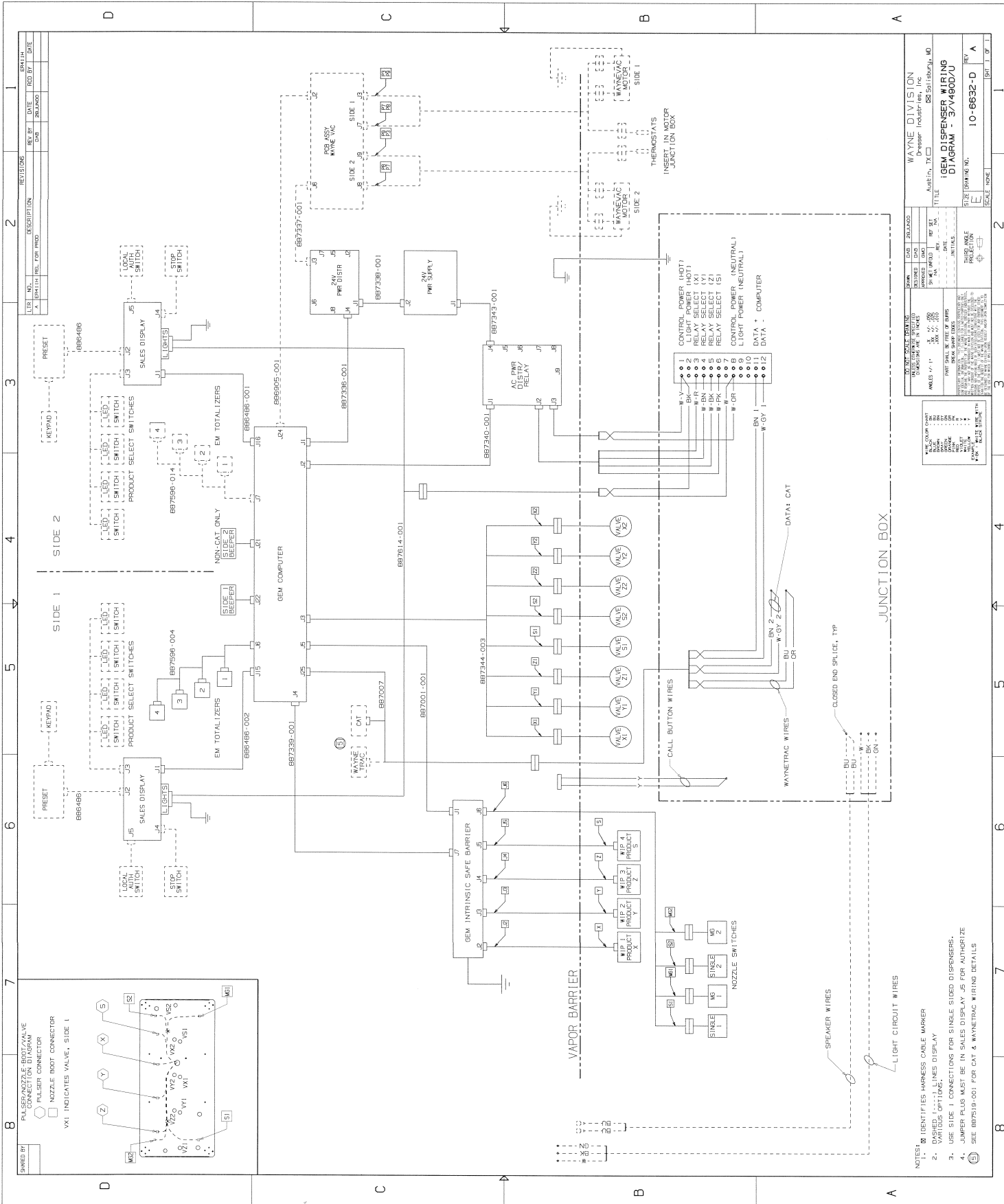

- NOTES:
1. W IDENTIFIES HARNESS CABLE MARKER
  2. VARIOUS OPTIONS
  3. USE SIDE 1 CONNECTIONS FOR SINGLE SIDED DISPENSERS.
  4. JUMPER PLUS MUST BE IN SALES DISPLAY J5 FOR AUTHORIZED
  5. SEE BB7519-001 FOR CAT & WAYNETRAC WIRING DETAILS

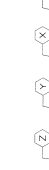

|  |                 |                  |               |
|--|-----------------|------------------|---------------|
| WAYNE DIVISION<br>Dresser Industries, Inc.<br>August, TX<br>August, TX | DOB<br>ZBLAND   | REV<br>REV 1     | DATE<br>11-59 |
| TITLE<br>GEM DISPENSER WIRING<br>DIAGRAM - 374800/U                    | DESIGNED<br>DND | REVISED<br>REV 1 | DATE<br>11-59 |
| SCALE<br>1:1   | SCALE<br>1:1    | SCALE<br>1:1     | SCALE<br>1:1  |

|       |     |             |
|-------|-----|-------------|
| DATE  | BY  | DESCRIPTION |
| 11-59 | DND | REVISED     |
| 11-59 | DND | REVISED     |

|        |        |        |        |
|--------|--------|--------|--------|
| WIRING | WIRING | WIRING | WIRING |
| WIRING | WIRING | WIRING | WIRING |
| WIRING | WIRING | WIRING | WIRING |

|        |        |        |        |
|--------|--------|--------|--------|
| WIRING | WIRING | WIRING | WIRING |
| WIRING | WIRING | WIRING | WIRING |
| WIRING | WIRING | WIRING | WIRING |

|        |        |        |        |
|--------|--------|--------|--------|
| WIRING | WIRING | WIRING | WIRING |
| WIRING | WIRING | WIRING | WIRING |
| WIRING | WIRING | WIRING | WIRING |

|        |        |        |        |
|--------|--------|--------|--------|
| WIRING | WIRING | WIRING | WIRING |
| WIRING | WIRING | WIRING | WIRING |
| WIRING | WIRING | WIRING | WIRING |

|        |        |        |        |
|--------|--------|--------|--------|
| WIRING | WIRING | WIRING | WIRING |
| WIRING | WIRING | WIRING | WIRING |
| WIRING | WIRING | WIRING | WIRING |

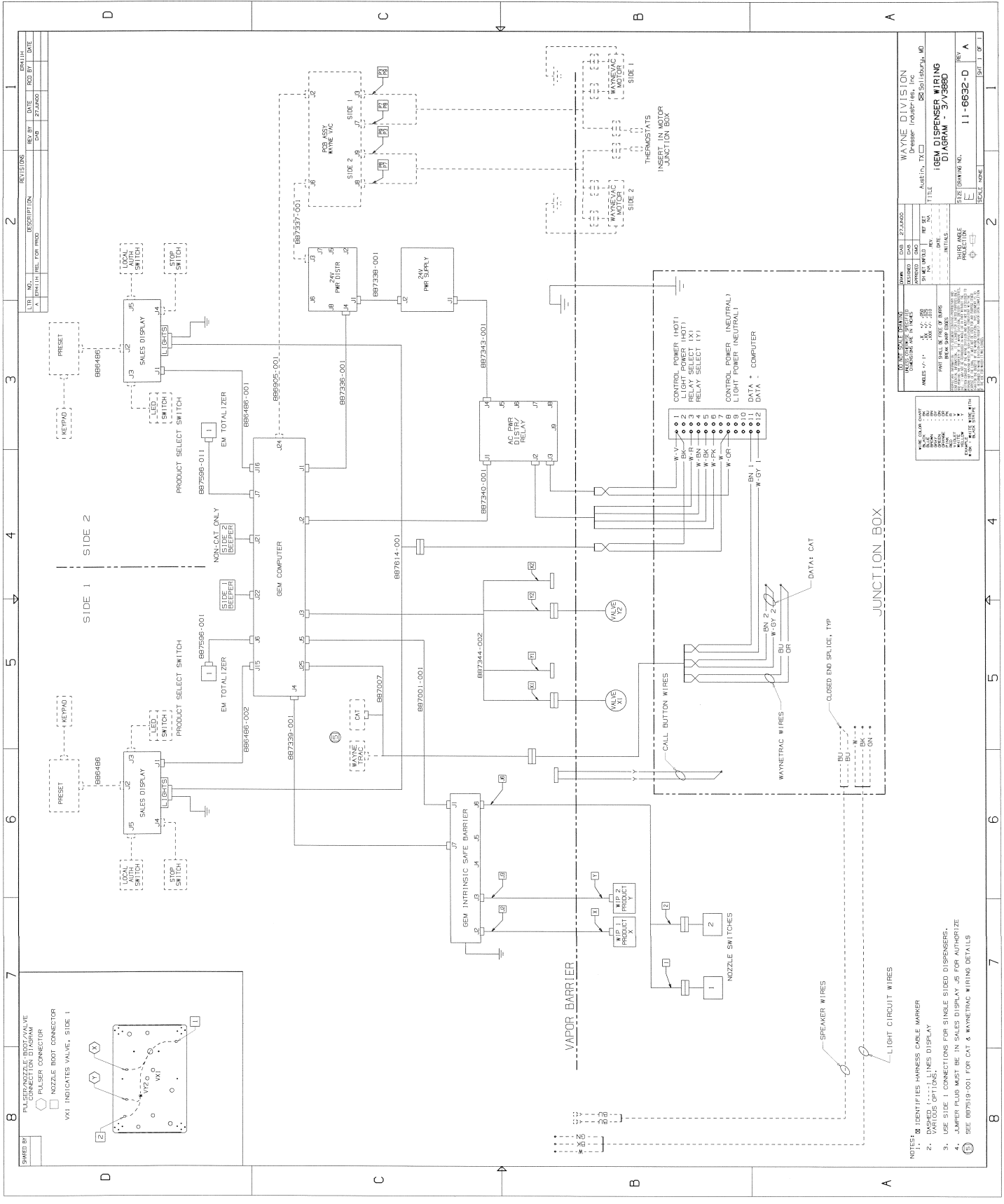

| REV. BY | DATE      | DESCRIPTION | EXT. NO. | QUANTITY |
|---------|-----------|-------------|----------|----------|
| 1       | 11-6632-D | 11-6632-D   |          |          |

| REV. BY | DATE      | DESCRIPTION | EXT. NO. | QUANTITY |
|---------|-----------|-------------|----------|----------|
| 1       | 11-6632-D | 11-6632-D   |          |          |

| DATE      | BY | APP'D. | CHK'D. | REV. | DESCRIPTION |
|-----------|----|--------|--------|------|-------------|
| 11-6632-D |    |        |        |      | 11-6632-D   |

| DATE      | BY | APP'D. | CHK'D. | REV. | DESCRIPTION |
|-----------|----|--------|--------|------|-------------|
| 11-6632-D |    |        |        |      | 11-6632-D   |

| DATE      | BY | APP'D. | CHK'D. | REV. | DESCRIPTION |
|-----------|----|--------|--------|------|-------------|
| 11-6632-D |    |        |        |      | 11-6632-D   |

| DATE      | BY | APP'D. | CHK'D. | REV. | DESCRIPTION |
|-----------|----|--------|--------|------|-------------|
| 11-6632-D |    |        |        |      | 11-6632-D   |

| DATE      | BY | APP'D. | CHK'D. | REV. | DESCRIPTION |
|-----------|----|--------|--------|------|-------------|
| 11-6632-D |    |        |        |      | 11-6632-D   |

NOTES:  
 1. IDENTIFIES HARNESS CABLE MARKER  
 2. DASHED LINES DISPLAY  
 3. VARIOUS OPTIONS  
 4. USE SIDE 1 CONNECTIONS FOR SINGLE SIDED DISPENSERS.  
 5. JUMPER PLUG MUST BE IN SALES DISPLAY JS FOR AUTHORIZED  
 6. SEE 897519-001 FOR CAT & WAYNETRAC WIRING DETAILS



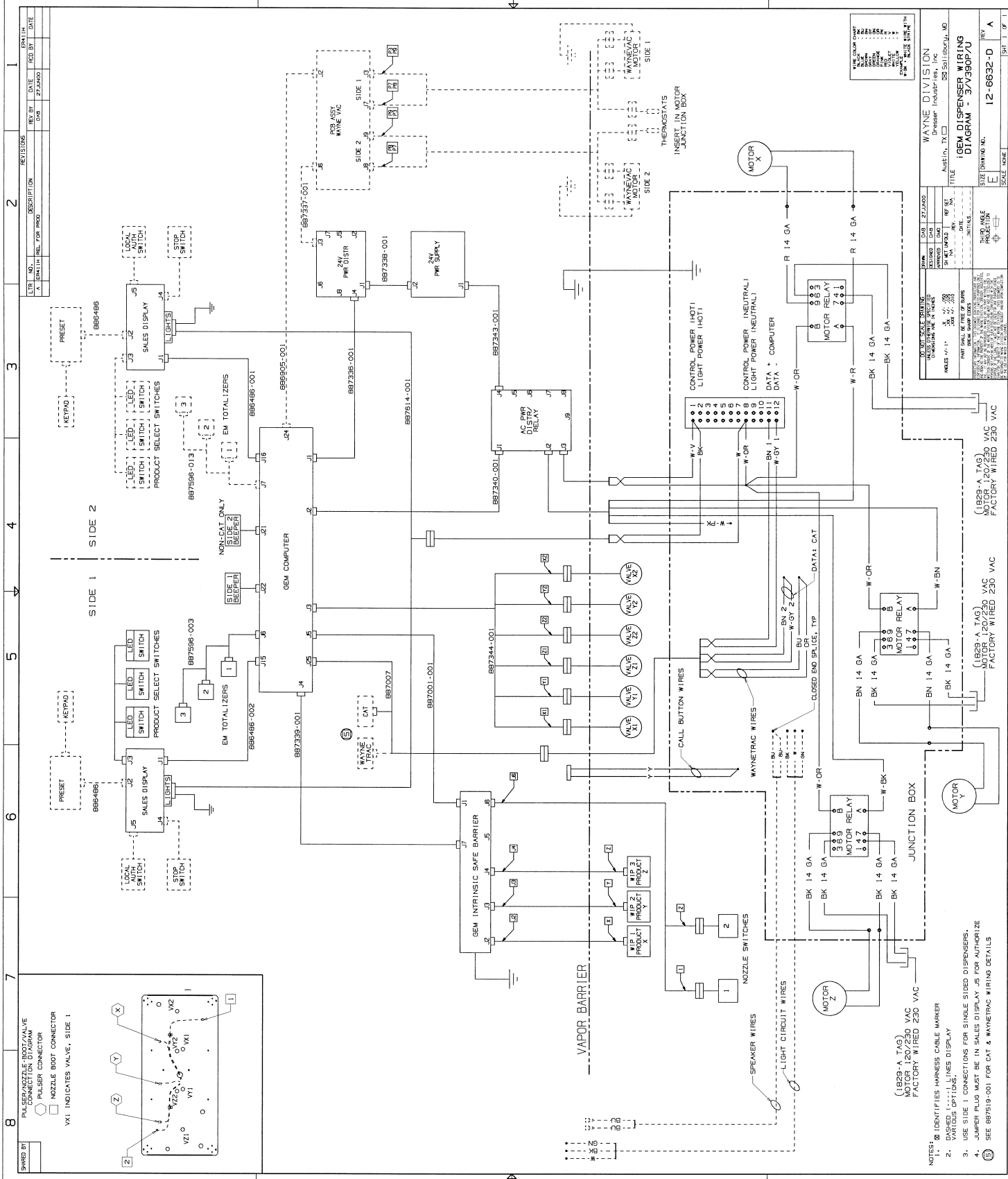

| DATE      | BY | DESCRIPTION |
|-----------|----|-------------|
| 12-6632-D |    |             |

|           |    |             |
|-----------|----|-------------|
| DATE      | BY | DESCRIPTION |
| 12-6632-D |    |             |

|           |    |             |
|-----------|----|-------------|
| DATE      | BY | DESCRIPTION |
| 12-6632-D |    |             |

WAYNE DIVISION  
 Dallas, TX 75240  
 TITLE: GEM DISPENSER WIRING DIAGRAM - 37438P/U  
 DRAWING NO. 12-6632-D  
 SCALE: NONE  
 SHEET 1 OF 1

DO NOT SCALE DRAWING  
 UNLESS INDICATED OTHERWISE  
 MAKE 1/4" = 1" (SEE 887519-001)  
 PWT SHALL BE FILED IN SUPP  
 DATE: 12-6632-D  
 12-6632-D

(1829-A TAG)  
 MOTOR 120/230 VAC  
 FACTORY WIRED 230 VAC

(1829-A TAG)  
 MOTOR 120/230 VAC  
 FACTORY WIRED 230 VAC

NOTES:  
 1. 8 IDENTIFIES HARNESS CABLE MARKER  
 2. VARIOUS OPTIONS  
 3. USE SIDE 1 CONNECTIONS FOR SINGLE SIDED DISPENSERS.  
 4. JUMPER PLUG MUST BE IN SALES DISPLAY J5 FOR AUTHORIZED



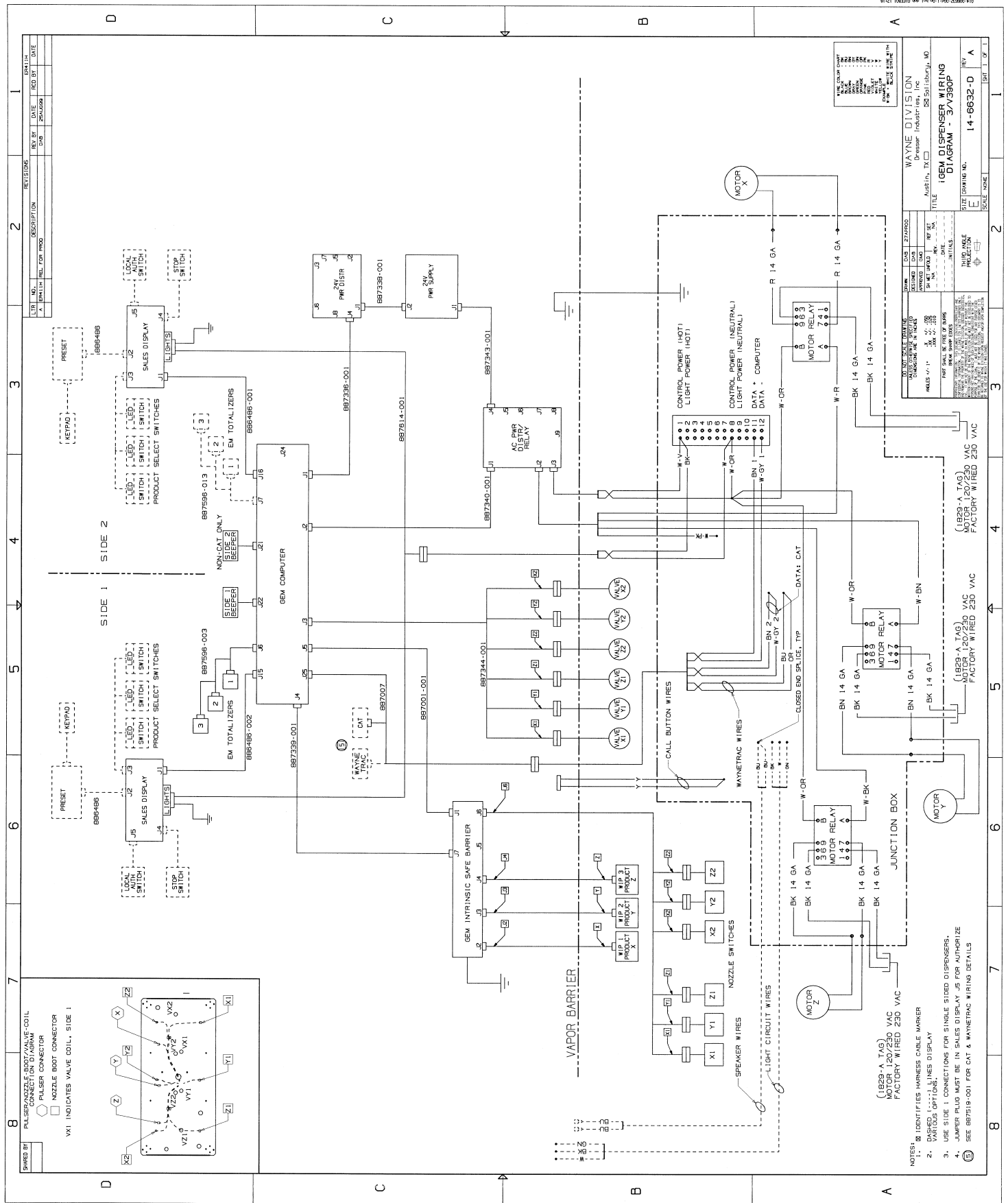

8 PULSER/NOZZLE BOOT/VALVE COIL CONNECTION DIAGRAM  
 ○ PULSER CONNECTOR  
 □ NOZZLE BOOT CONNECTOR  
 VX1 INDICATES VALVE COIL, SIDE 1

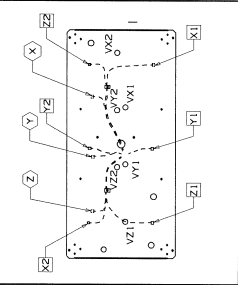

- NOTES:
- IDENTIFIES IMPRESS DISPLAY
  - IDENTIFIES WIRE DISPLAY
  - USE SIDE 1 CONNECTIONS FOR SINGLE SIDED DISPENSERS.
  - JAMPER PLUG MUST BE IN SALES DISPLAY J5 FOR AUTHORITY
  - SEE 887519-001 FOR CAT & WAYNETRAC WIRING DETAILS

| REV. | DATE | DESCRIPTION | BY | CHKD. |
|------|------|-------------|----|-------|
| 1    |      |             |    |       |
| 2    |      |             |    |       |
| 3    |      |             |    |       |
| 4    |      |             |    |       |
| 5    |      |             |    |       |
| 6    |      |             |    |       |
| 7    |      |             |    |       |
| 8    |      |             |    |       |

| NO. | DATE | DESCRIPTION | BY | CHKD. |
|-----|------|-------------|----|-------|
| 1   |      |             |    |       |
| 2   |      |             |    |       |
| 3   |      |             |    |       |
| 4   |      |             |    |       |
| 5   |      |             |    |       |
| 6   |      |             |    |       |
| 7   |      |             |    |       |
| 8   |      |             |    |       |

| REV. | DATE | DESCRIPTION | BY | CHKD. |
|------|------|-------------|----|-------|
| 1    |      |             |    |       |
| 2    |      |             |    |       |
| 3    |      |             |    |       |
| 4    |      |             |    |       |
| 5    |      |             |    |       |
| 6    |      |             |    |       |
| 7    |      |             |    |       |
| 8    |      |             |    |       |

| REV. | DATE | DESCRIPTION | BY | CHKD. |
|------|------|-------------|----|-------|
| 1    |      |             |    |       |
| 2    |      |             |    |       |
| 3    |      |             |    |       |
| 4    |      |             |    |       |
| 5    |      |             |    |       |
| 6    |      |             |    |       |
| 7    |      |             |    |       |
| 8    |      |             |    |       |

| REV. | DATE | DESCRIPTION | BY | CHKD. |
|------|------|-------------|----|-------|
| 1    |      |             |    |       |
| 2    |      |             |    |       |
| 3    |      |             |    |       |
| 4    |      |             |    |       |
| 5    |      |             |    |       |
| 6    |      |             |    |       |
| 7    |      |             |    |       |
| 8    |      |             |    |       |

| REV. | DATE | DESCRIPTION | BY | CHKD. |
|------|------|-------------|----|-------|
| 1    |      |             |    |       |
| 2    |      |             |    |       |
| 3    |      |             |    |       |
| 4    |      |             |    |       |
| 5    |      |             |    |       |
| 6    |      |             |    |       |
| 7    |      |             |    |       |
| 8    |      |             |    |       |

| REV. | DATE | DESCRIPTION | BY | CHKD. |
|------|------|-------------|----|-------|
| 1    |      |             |    |       |
| 2    |      |             |    |       |
| 3    |      |             |    |       |
| 4    |      |             |    |       |
| 5    |      |             |    |       |
| 6    |      |             |    |       |
| 7    |      |             |    |       |
| 8    |      |             |    |       |

WAYNE DIVISION  
 Dresser Industries, Inc.  
 Houston, TX  
 I6EM DISPENSER WIRING  
 DIAGRAM - 3V380P  
 DRAWING NO. 14-6632-D  
 SCALE NONE



| REV. NO. | DATE     | REV. BY | DATE | REV. BY | DATE |
|----------|----------|---------|------|---------|------|
| 1        | 12/20/60 |         |      |         |      |
| 2        | 1/27/60  |         |      |         |      |
| 3        | 2/1/60   |         |      |         |      |
| 4        | 2/1/60   |         |      |         |      |
| 5        | 2/1/60   |         |      |         |      |
| 6        | 2/1/60   |         |      |         |      |
| 7        | 2/1/60   |         |      |         |      |
| 8        | 2/1/60   |         |      |         |      |

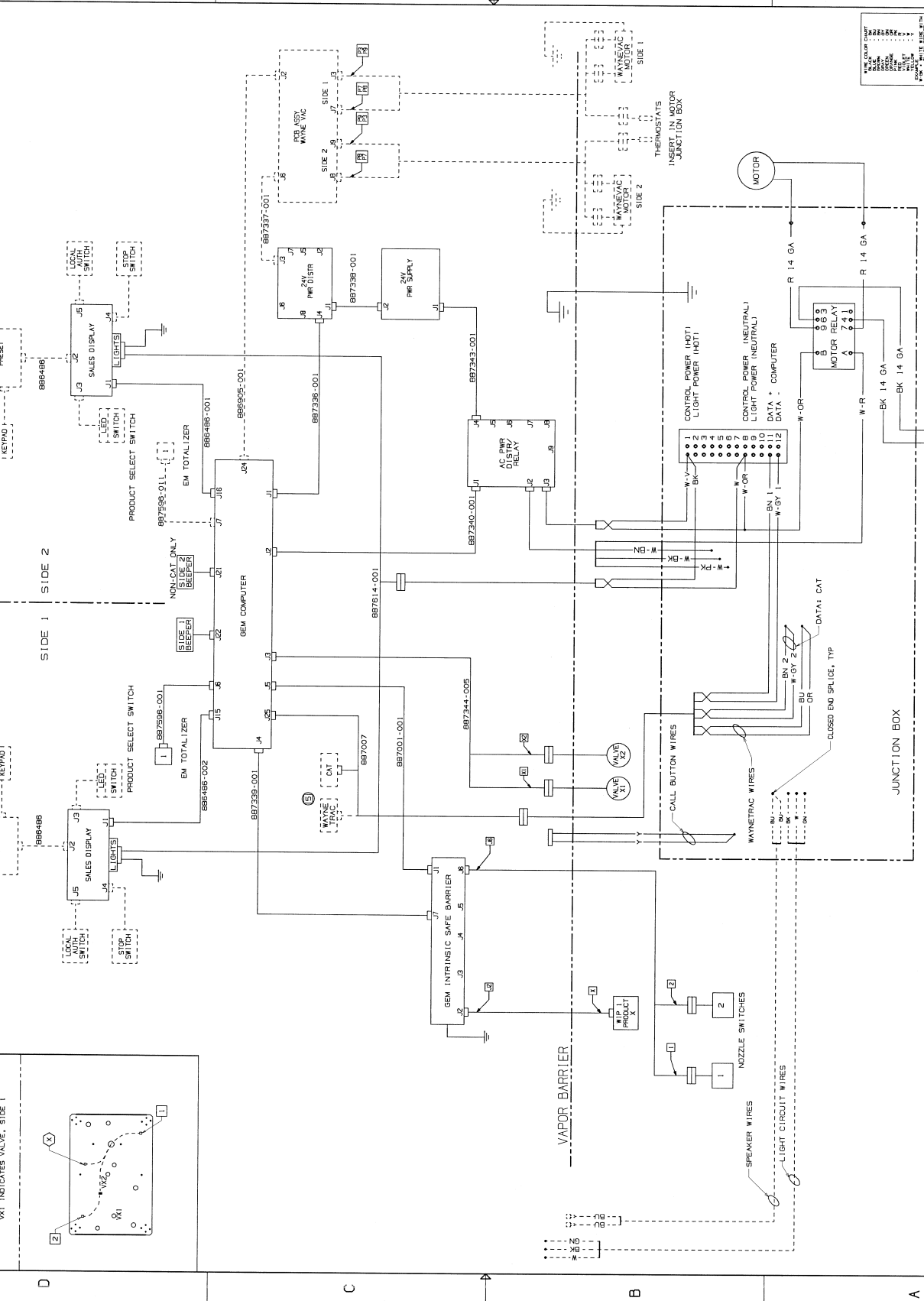

| NO. | DATE     | REV. | BY | DATE | REV. | BY | DATE |
|-----|----------|------|----|------|------|----|------|
| 1   | 12/20/60 |      |    |      |      |    |      |
| 2   | 1/27/60  |      |    |      |      |    |      |
| 3   | 2/1/60   |      |    |      |      |    |      |
| 4   | 2/1/60   |      |    |      |      |    |      |
| 5   | 2/1/60   |      |    |      |      |    |      |
| 6   | 2/1/60   |      |    |      |      |    |      |
| 7   | 2/1/60   |      |    |      |      |    |      |
| 8   | 2/1/60   |      |    |      |      |    |      |

WAYNE DIVISION  
 Wayne Industries, Inc.  
 Austin, TX  
 TITLE: GEM DISPENSER WIRING DIAGRAM - 3/1587P  
 SIZE: DRAWING NO. 18-8632-D  
 SHEET NO. 1 OF 1

NOTES:  
 1. IDENTIFIES WIRE/CABLE MARKER  
 2. DASHED (---) LINES DISPLAY  
 3. USE SIDE 1 CONNECTIONS FOR SINGLE SIDED DISPENSERS.  
 4. JUMPER PLUG MUST BE IN SALES DISPLAY J5 FOR AUTHORIZED  
 5. SEE 8B7519-001 FOR CAT & WAYNETRAC WIRING DETAILS

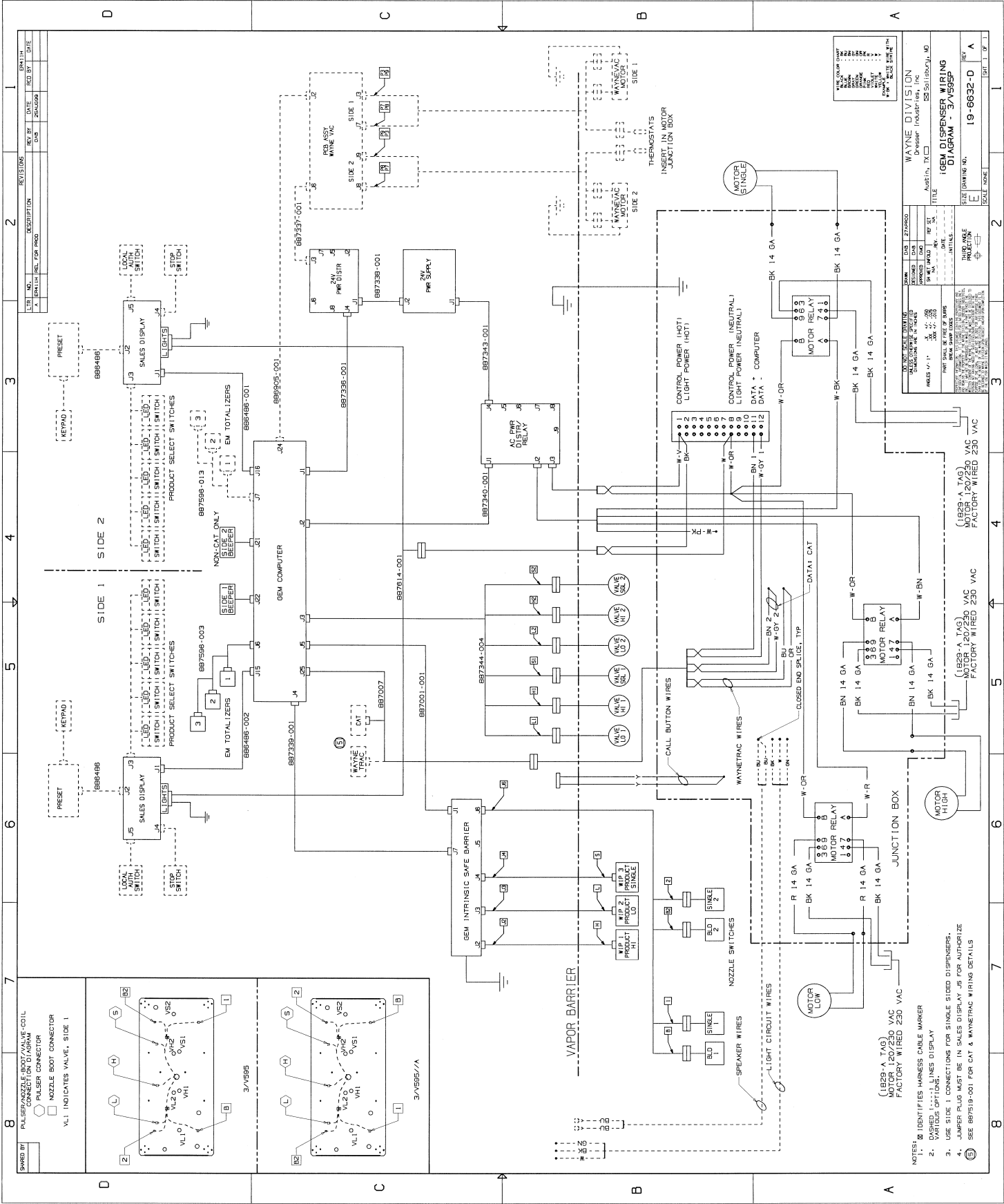

| REV. NO. | DESCRIPTION | REV. BY | REV. DATE | ENH/INT | ENH/INT FOR PROD | ENH/INT DATE |
|----------|-------------|---------|-----------|---------|------------------|--------------|
| 1        |             |         |           |         |                  |              |
| 2        |             |         |           |         |                  |              |
| 3        |             |         |           |         |                  |              |
| 4        |             |         |           |         |                  |              |
| 5        |             |         |           |         |                  |              |
| 6        |             |         |           |         |                  |              |
| 7        |             |         |           |         |                  |              |

WAYNE DIVISION  
Dresser Industries, Inc.  
Austin, TX  
19-6632-D (REV. 12-78)  
iGEM DISPENSER WIRING  
DIAGRAM - 3/V955F

|          |             |         |           |
|----------|-------------|---------|-----------|
| REV. NO. | DESCRIPTION | REV. BY | REV. DATE |
| 1        |             |         |           |
| 2        |             |         |           |
| 3        |             |         |           |
| 4        |             |         |           |
| 5        |             |         |           |
| 6        |             |         |           |
| 7        |             |         |           |

SCALE: NONE

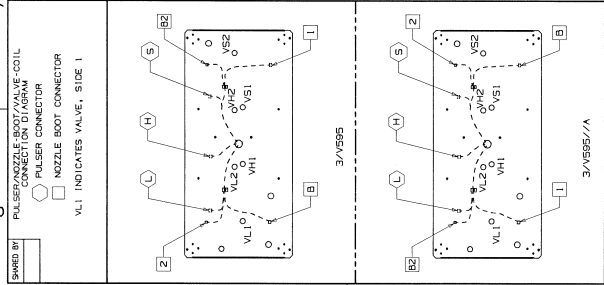

- NOTES:
1. IDENTIFIES HARNESS CABLE MARKER
  2. DASHED (---) LINES DISPLAY VARIOUS OPTIONS.
  3. USE SIDE 1 CONNECTIONS FOR SINGLE SIZED DISPENSERS.
  4. JUMPER PLUG MUST BE IN SALES DISPLAY J5 FOR AUTHORIZED VARIOUS OPTIONS.
- SEE 8B7519-001 FOR CAT & WAYNETRAC WIRING DETAILS



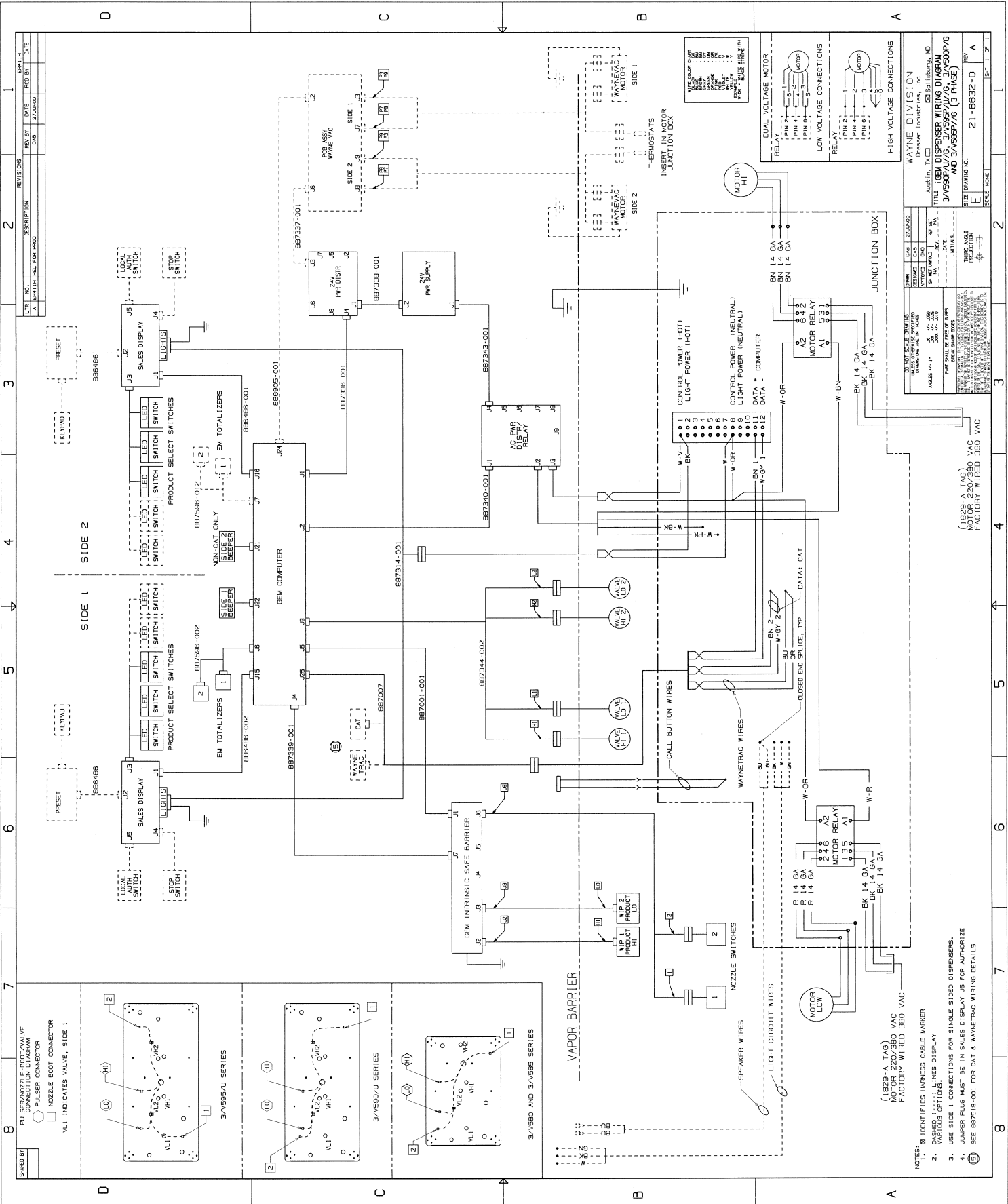

NOTES:  
 1. IDENTIFIES HARNESS CABLE MARKER  
 2. DASHED LINES DISPLAY VARIOUS OPTIONS.  
 3. USE SIDE 1 CONNECTIONS FOR SINGLE SIDED DISPENSERS.  
 4. JUMPER PLUG MUST BE IN SALES DISPLAY J5 FOR AUTHORIZED SEE BB7515-001 FOR CAT & WAYNETRAC WIRING DETAILS

(1959 A T & G)  
 MOTOR 220/350 VAC  
 FACTORY WIRED 350 VAC

|        |            |                |             |
|--------|------------|----------------|-------------|
| REV. A | DATE 11/66 | BY J. H. MOORE | DESCRIPTION |
| REV. B | DATE 12/66 | BY J. H. MOORE | REVISIONS   |
| REV. C | DATE 1/67  | BY J. H. MOORE | REVISIONS   |
| REV. D | DATE 2/67  | BY J. H. MOORE | REVISIONS   |
| REV. E | DATE 3/67  | BY J. H. MOORE | REVISIONS   |

TITLE: GEM DISPENSER WIRING DIAGRAM  
 PART NO.: 21-6632-D  
 SCALE: NONE  
 SIZE: 11" x 17"



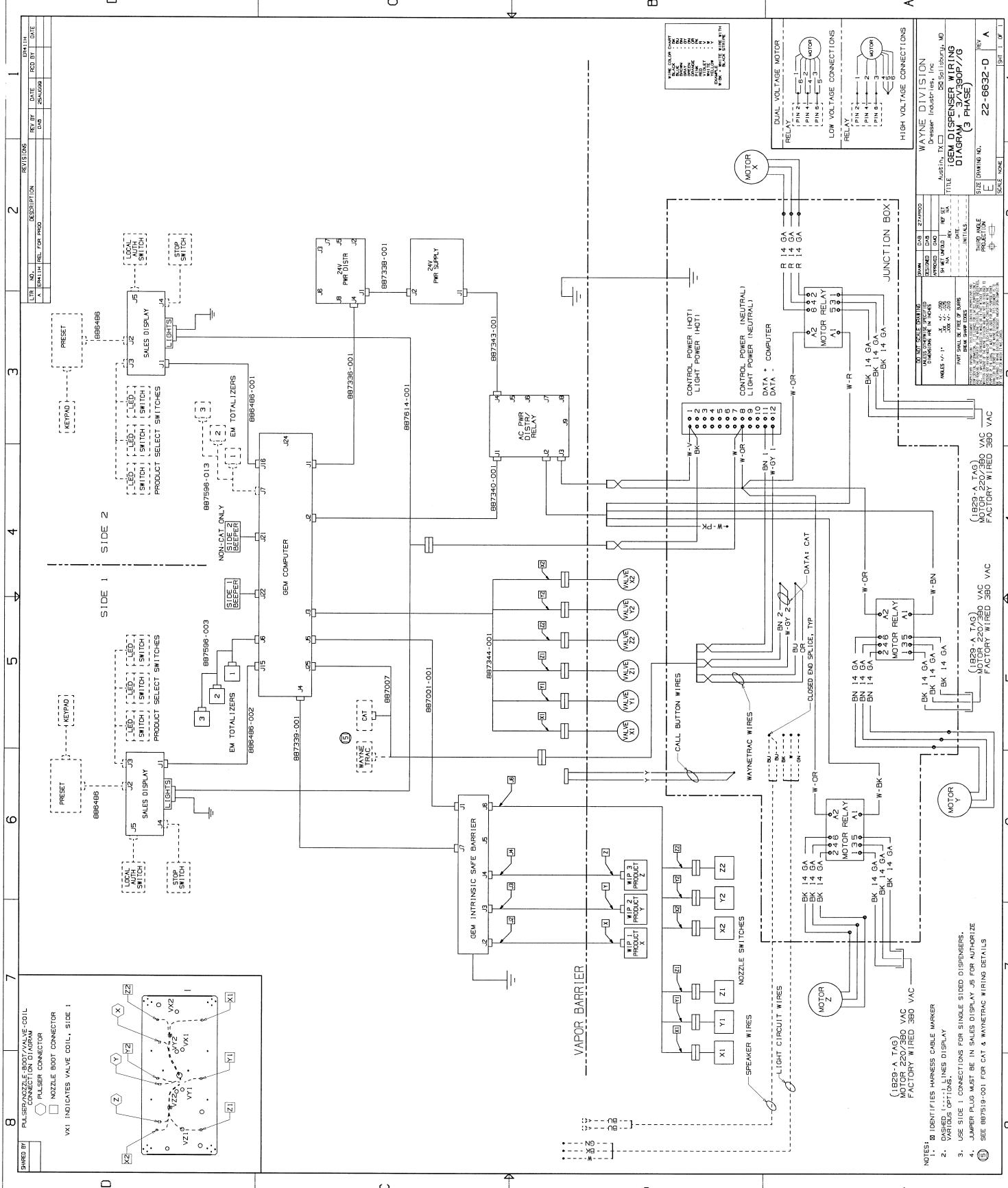

| REV. NO. | DATE     | DESCRIPTION           | REV. BY  | DATE |
|----------|----------|-----------------------|----------|------|
| 1        | 10/19/78 | ISSUED FOR PRODUCTION | PKAL/SJG |      |

| REV. NO. | DATE     | DESCRIPTION           | REV. BY  | DATE |
|----------|----------|-----------------------|----------|------|
| 2        | 10/19/78 | ISSUED FOR PRODUCTION | PKAL/SJG |      |

| REV. NO. | DATE     | DESCRIPTION           | REV. BY  | DATE |
|----------|----------|-----------------------|----------|------|
| 3        | 10/19/78 | ISSUED FOR PRODUCTION | PKAL/SJG |      |

| REV. NO. | DATE     | DESCRIPTION           | REV. BY  | DATE |
|----------|----------|-----------------------|----------|------|
| 4        | 10/19/78 | ISSUED FOR PRODUCTION | PKAL/SJG |      |

| REV. NO. | DATE     | DESCRIPTION           | REV. BY  | DATE |
|----------|----------|-----------------------|----------|------|
| 5        | 10/19/78 | ISSUED FOR PRODUCTION | PKAL/SJG |      |

| REV. NO. | DATE     | DESCRIPTION           | REV. BY  | DATE |
|----------|----------|-----------------------|----------|------|
| 6        | 10/19/78 | ISSUED FOR PRODUCTION | PKAL/SJG |      |

| REV. NO. | DATE     | DESCRIPTION           | REV. BY  | DATE |
|----------|----------|-----------------------|----------|------|
| 7        | 10/19/78 | ISSUED FOR PRODUCTION | PKAL/SJG |      |

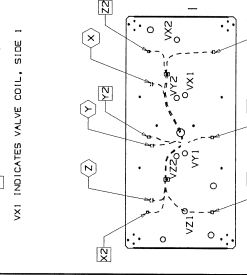

1. B IDENTIFIES HARNESS CABLE NUMBER  
 2. IDENTIFIES HARNESS CABLE NUMBER  
 3. IDENTIFIES HARNESS CABLE NUMBER  
 4. IDENTIFIES HARNESS CABLE NUMBER  
 5. IDENTIFIES HARNESS CABLE NUMBER

WAYNE DIVISION  
 AUGUST, TX  
 TITLE: GEM DISPENSER WIRING DIAGRAM (3 PHASE)  
 SIZE: DRAWING NO. 22-6632-D  
 SCALE: NONE  
 SHEET 1 OF 1

DUAL VOLTAGE MOTOR RELAY  
 LOW VOLTAGE CONNECTIONS  
 HIGH VOLTAGE CONNECTIONS

CONTROL POWER (HOT)  
 CONTROL POWER (NEUTRAL)  
 LIGHT POWER (NEUTRAL)  
 DATA \* COMPUTER

MOTOR Z  
 MOTOR Y  
 MOTOR X

(1B29-A TAG)  
 MOTOR 220/380 VAC  
 FACTORY WIRED 380 VAC

NOTES:  
 1. B IDENTIFIES HARNESS CABLE NUMBER  
 2. IDENTIFIES HARNESS CABLE NUMBER  
 3. IDENTIFIES HARNESS CABLE NUMBER  
 4. IDENTIFIES HARNESS CABLE NUMBER  
 5. IDENTIFIES HARNESS CABLE NUMBER



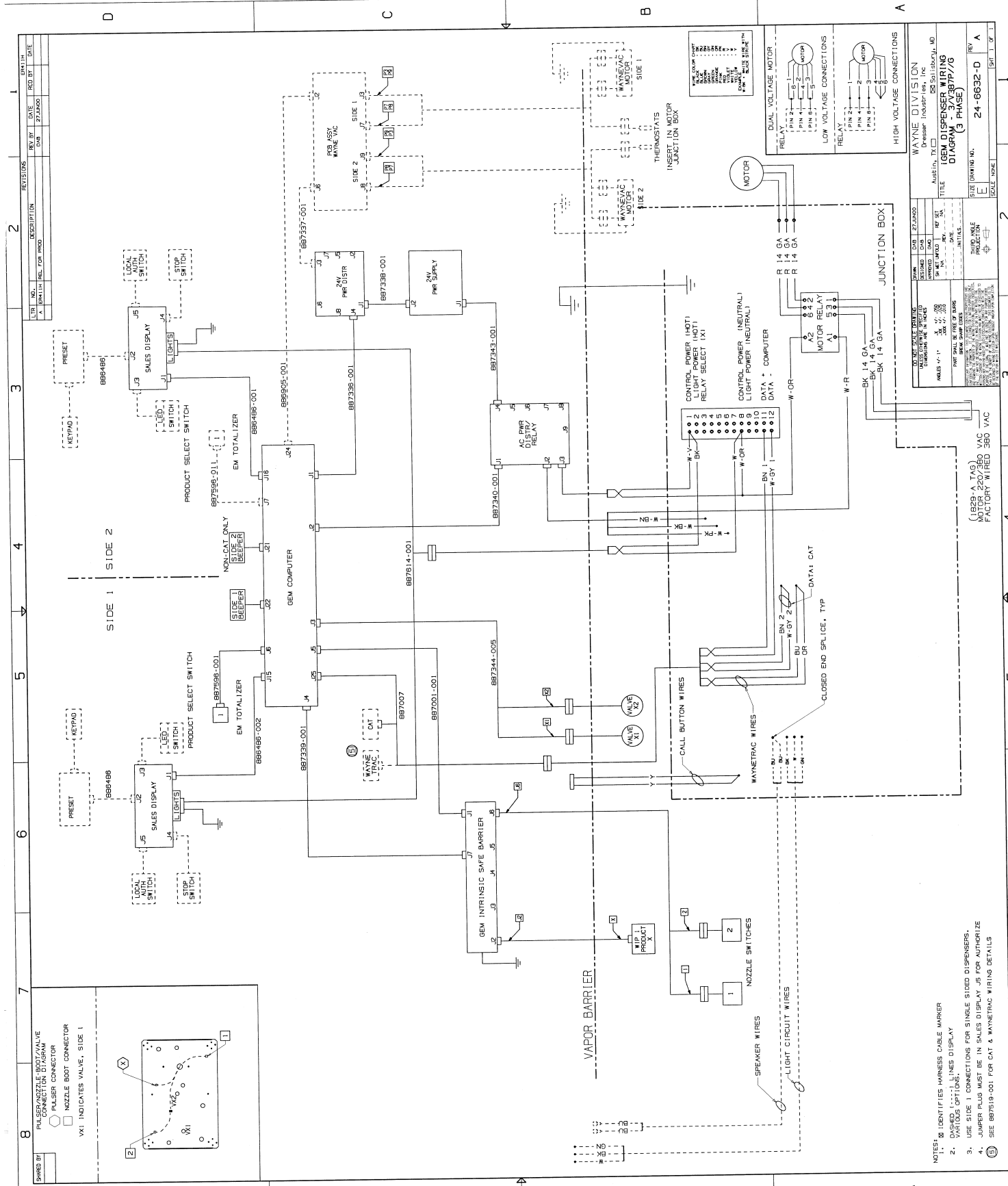

| REV. NO. | DESCRIPTION    | REV. BY | DATE      | REV. BY | DATE |
|----------|----------------|---------|-----------|---------|------|
| 1        | ISSUED FOR MFG | DAW     | 27 JAN 68 |         |      |

| REV. NO. | DESCRIPTION    | REV. BY | DATE      | REV. BY | DATE |
|----------|----------------|---------|-----------|---------|------|
| 1        | ISSUED FOR MFG | DAW     | 27 JAN 68 |         |      |

**WAYNE DIVISION**  
 Dresser Industries, Inc.  
 1000 W. 10th Street  
 Tulsa, Oklahoma 74103, U.S.A.

**TITLE**  
 GEM DISPENSER WIRING  
 DIAGRAM - 3/4/367//G  
 (3 PHASE)

**SIZE**  
 DRAWING NO. 24-6632-D  
 REV. A

**SCALE**  
 NONE

**INDUSTRY PRACTICES**  
 1. ALL WIRING SHALL BE IN ACCORDANCE WITH THE NATIONAL ELECTRICAL CODE (NEC) AND THE NATIONAL FIRE ALARMS ASSOCIATION (NFPA) WIRING BULLETIN (Wiring Practices).

**NOTES**  
 1. IDENTIFY WIRING CABLE MARKER  
 2. DASHED (---) LINES DISPLAY VARIOUS OPTIONS.  
 3. USE SIDE 1 CONNECTIONS FOR SINGLE SIDED DISPENSERS.  
 4. JUMPER PLUG MUST BE IN SALES DISPLAY J5 FOR AUTHORIZED  
 5. SEE BB7519-001 FOR DAT & WAYNETRAC WIRING DETAILS

- NOTES:**
1. IDENTIFIES WIRING CABLE MARKER
  2. DASHED (---) LINES DISPLAY VARIOUS OPTIONS.
  3. USE SIDE 1 CONNECTIONS FOR SINGLE SIDED DISPENSERS.
  4. JUMPER PLUG MUST BE IN SALES DISPLAY J5 FOR AUTHORIZED
  5. SEE BB7519-001 FOR DAT & WAYNETRAC WIRING DETAILS



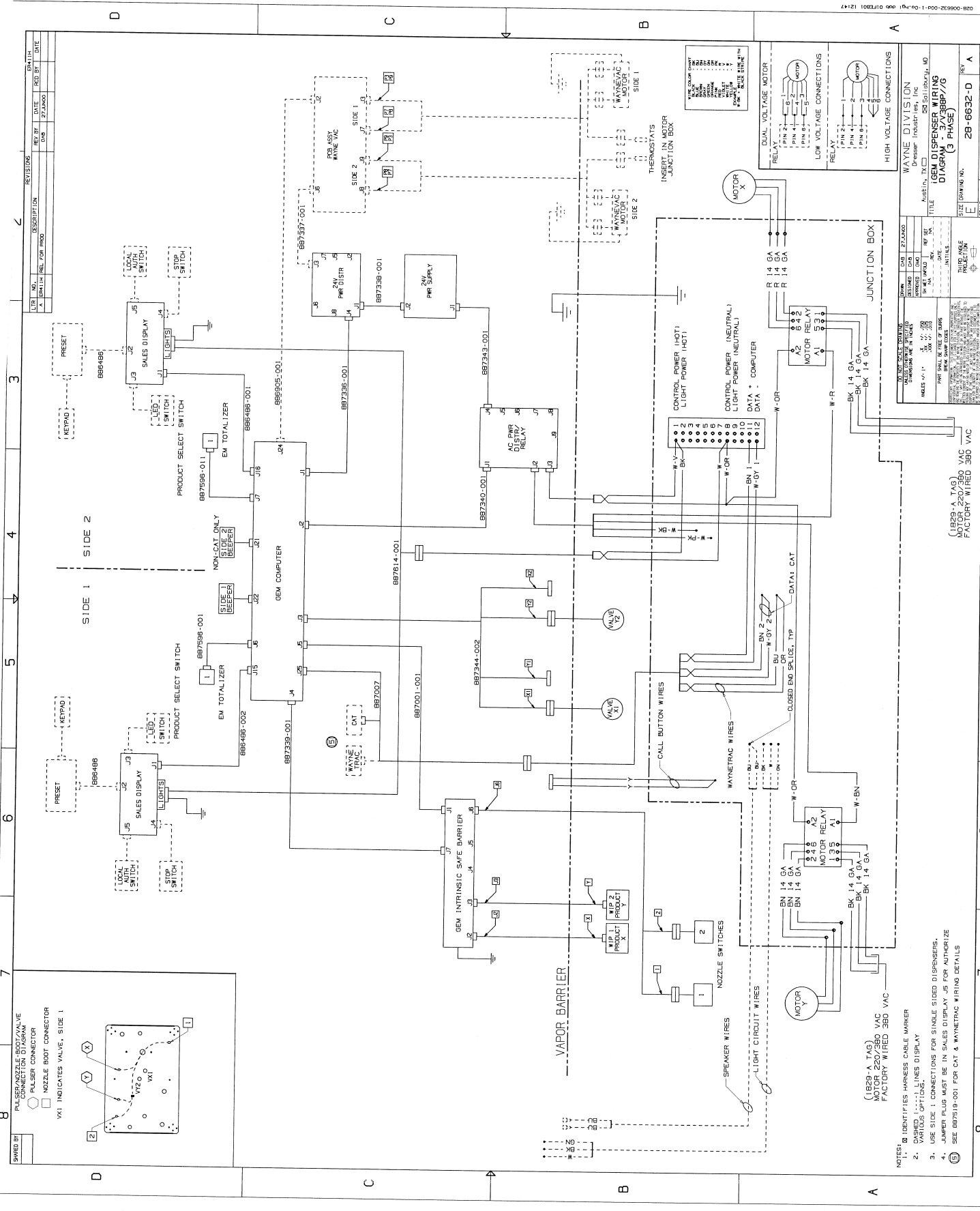

| REV | DATE     | BY | CHKD BY |
|-----|----------|----|---------|
| 1   | 02/20/00 |    |         |
| 2   | 02/20/00 |    |         |

|          |          |
|----------|----------|
| DATE     | 02/20/00 |
| DESIGNED | 02/20/00 |
| DATE     | 02/20/00 |
| BY       | 02/20/00 |
| DATE     | 02/20/00 |
| BY       | 02/20/00 |
| DATE     | 02/20/00 |
| BY       | 02/20/00 |

WAYNE DIVISION  
 1629-A TAG  
 GEM DISPENSER WIRING  
 DIAGRAM - 3/2/88P//G  
 (3 PHASE)

28-6632-D

(1629-A TAG)  
 MOTOR 220/380 VAC  
 FACTORY WIRED 380 VAC

NOTES:

- ① IDENTIFIES HARNESS CABLE NUMBER
- ② VARIOUS OPTICAL LINES DISPLAY
- ③ USE SIDE 1 CONNECTIONS FOR SINGLE SIDED DISPENSERS.
- ④ JUMPER PLUG MUST BE IN SALES DISPLAY JS FOR AUTHORIZED
- ⑤ SEE 807519-001 FOR CAT & WAYNETRAC WIRING DETAILS

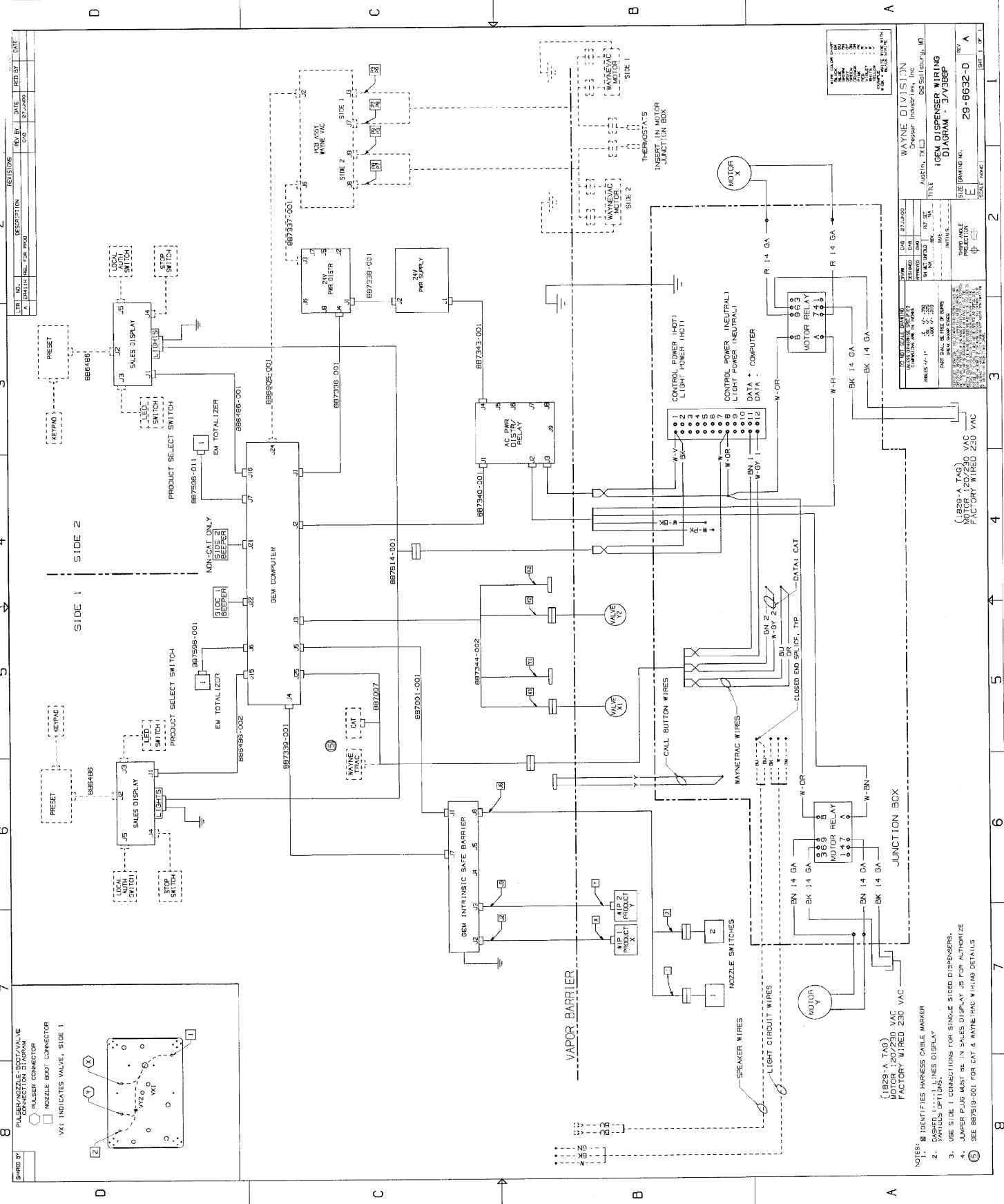

| REV. NO. | DATE     | REV. BY             | DATE     |
|----------|----------|---------------------|----------|
| 1        | 01/11/81 | W. J. P. / P. J. P. | 07/23/80 |
| 2        | 01/11/81 | W. J. P. / P. J. P. | 07/23/80 |

| REV. NO. | DATE     | REV. BY             | DATE     |
|----------|----------|---------------------|----------|
| 1        | 01/11/81 | W. J. P. / P. J. P. | 07/23/80 |
| 2        | 01/11/81 | W. J. P. / P. J. P. | 07/23/80 |

|  |  |
|--|--|
| WAYNE DIVISION<br>CHESTER, PENNSYLVANIA 19380<br>TITLE: ISEM DISPENSER WIRING DIAGRAM - 3V388P<br>DRAWING NO.: 29-6632-D<br>REV: A |  |
| PART NO. 297343-001<br>QUANTITY 1<br>UNIT PRICE \$10.00<br>TOTAL \$10.00   | PART NO. 297343-002<br>QUANTITY 1<br>UNIT PRICE \$10.00<br>TOTAL \$10.00 |
| PART NO. 297343-003<br>QUANTITY 1<br>UNIT PRICE \$10.00<br>TOTAL \$10.00   | PART NO. 297343-004<br>QUANTITY 1<br>UNIT PRICE \$10.00<br>TOTAL \$10.00 |
| PART NO. 297343-005<br>QUANTITY 1<br>UNIT PRICE \$10.00<br>TOTAL \$10.00   | PART NO. 297343-006<br>QUANTITY 1<br>UNIT PRICE \$10.00<br>TOTAL \$10.00 |

(1829-A TAG)  
 MOTOR 120/230 VAC  
 FACTORY WIRED 230 VAC

NOTES:  
 1. B IDENTIFIES HARNESS CABLE MARKER  
 2. VARIOUS OPTIONS.  
 3. USE SIDE 1 CONNECTIONS FOR SINGLE SIDED DISPENSERS.  
 4. JUMPER P-LUG MUST BE IN SALES DISPLAY AS FOR AUTHORIZED  
 SEE 887519-001 FOR CAT & WAYNETAC WIRING DETAILS

# SERVICE

## 3/Vista Series Blending and Non-Blending Dispensers

Written by S. G. Martin

This manual was produced using Adobe® FrameMaker® and Adobe® PhotoShop®

Page design uses Times New Roman and Arial Fonts

Manuals were electronically produced on a Xerox Docutech 135 Publishing System at 600 dpi

© Copyright 2001 Dresser, Inc.

All rights reserved.

Printed in the United States of America.

Adobe® FrameMaker® and Adobe® PhotoShop® are trademarks of Adobe Systems, Inc.

This manual and the software described within are furnished under license and may be used or copied only in accordance with the terms of such license.

No part of this publication may be electronically or mechanically reproduced, stored in a retrieval system, or transmitted, in any form or by any means, except as permitted by such license. Translation of this material to another language without express written permission of Dresser, Inc. is prohibited.

The information in this publication is for informational use only and is subject to change without notice. The contents should not be construed as a commitment by Dresser, Inc. who assumes no responsibility or liability for inaccuracies that may appear in this publication.

**Dresser Wayne, Dresser, Inc., is located at 3814 Jarrett Way, Austin TX 78728.  
Wayne's general telephone number is (512)-388-8311.**

**NOTE:** “This equipment has been tested and found to comply with the limits for a Class A digital device, pursuant to Part 15 of the FCC Rules. These limits are designed to provide reasonable protection against harmful interference when the equipment is operated in a commercial environment. This equipment generates, uses, and can radiate radio frequency energy and, if not installed and used in accordance with the instruction manual, may cause harmful interference to radio communications. Operation of this equipment in a residential area is likely to cause harmful interference in which case the user will be required to correct the interference at his own expense.”



**Wayne**

Wayne Division, Dresser, Inc.

3814 Jarrett Way, Austin, TX 78728

(512) 388-8311

Part No. 920525 Rev A

©2001 Dresser, Inc.

100/7/01