

INSTALLATION OPERATION

Wayne Century
Suction Pumps
& Remote Dispensers
3/G2200 Series





DANGER

READ THIS MANUAL BEFORE YOU BEGIN

Dispensers have both electricity and a hazardous, flammable, and potentially explosive liquid. Failure to follow the below precautions and the Warning and Caution instructions in this manual may result in serious injury or death. Read every tag attached to the dispenser before commencing installation. Follow all rules, codes, and laws that apply to your area and installation.

SAFETY PRECAUTIONS - INSTALLATION AND MAINTENANCE

Always make sure ALL power to the dispenser (motors and electronic head) is turned OFF before you open the dispenser cabinet for maintenance. Physically lock, restrict access to, or tag the circuit breakers you turn off when servicing the dispenser. If applicable, be sure to trip (close) the emergency valve(s) under the dispenser BEFORE beginning maintenance.

Make sure that you know how to turn OFF power to the dispenser and submersible pumps in an emergency. Have all leaks or defects repaired immediately.

EQUIPMENT PRECAUTIONS

Be sure to bleed all air from the product lines of remote dispensers and prime suction pumps before dispensing product, otherwise, damage to the equipment may occur. Always use the approved method for lifting the dispenser. Never lift by the nozzle boot, sheet metal, etc., otherwise equipment damage or personal injury may occur.

USE ONLY GENUINE PARTS

For product liability to be valid, no changes may be made to the equipment without the written consent of Dresser Wayne.

HOW TO CONTACT DRESSER WAYNE

Trouble with the installation and operation of the pump should be referred to your authorized Wayne[®] service personnel or Wayne Technical Support (1-800-926-3737).

INDICATORS AND NOTATIONS



DANGER

Danger indicates a hazard or unsafe practice which, if not avoided, will result in severe injury or possibly death.



WARNING

Warning indicates a hazard or unsafe practice which, if not avoided, may result in severe injury or possibly death.



CAUTION

Caution indicates a hazard or unsafe practice which, if not avoided, may result in minor injury.

NOTE:

Important information to consider, otherwise, improper installation and/or damage to components may occur.

Table of Contents

Title	Page
1 INTRODUCTION	1
1.1 Dispensers Covered	1
1.2 Model Description	2
1.2.1 Standard/Enhanced Capacity Models	2
1.2.2 Super High Capacity Models	3
1.2.3 Super High Capacity Satellite Models	3
1.2.4 Ultra High Capacity Dispenser Models	4
1.2.5 Ultra High Capacity Satellite Dispenser Models	5
1.3 Model Designation Format	6
1.4 Technical Information	8
2 SITE DESIGN & PREPARATION	11
2.1 Local, State, and Federal Codes	11
2.2 Safety Precautions	12
2.3 Existing Installations	13
2.4 Island Construction, Dispenser Anchoring, and Piping	14
2.5 Suction Pump Installations	14
2.5.1 Suction Pumps – General	14
2.5.2 Suction Pumps with Aboveground Tanks	14
2.5.3 Suction Pump Check Valves	15
2.5.4 Connecting More Than One Suction Pump to a Tank	15
2.6 Remote Dispenser Applications	16
3 INSTALLATION	17
3.1 Equipment Inspection	17
3.2 Lifting and Installing the Dispenser	17
3.3 Electrical Wiring	18
3.3.1 General	18
3.3.2 Electrical Termination Descriptions – All Dispensers	18
3.3.3 Electrical Termination Descriptions – Master Dispenser Models	20
3.3.4 Circuit Breakers & Emergency Electrical Disconnect	22
3.3.5 Pump Motor Voltage Setting	22
3.3.6 Grounding	23
3.3.7 Wiring	23
3.3.8 Conduit	24
3.4 Hose and Accessories Installation	25
3.4.1 General	25
3.4.2 Vapor Recovery Nozzles	25

Table of Contents (continued)

Title	Page
4 START-UP	27
4.1 Initial Checkout	27
4.2 Configuring the Dispenser Software	28
4.2.1 General	28
4.2.2 Making Configuration Changes	28
4.2.3 Configuration Start-Up	29
4.3 Priming Suction Pumps	32
4.4 Bleeding Product Lines (Remote Dispensers)	33
4.5 Initial Delivery	33
4.6 Meter Check (Calibration) – Standard/Enhanced Capacity & Super High Capacity	34
4.6.1 General	34
4.6.2 Accuracy Verification – Standard/Enhanced Capacity & Super High Capacity	34
4.6.3 Calibration Procedure – Standard/Enhanced Capacity & Super High Capacity	35
4.7 Meter Check (Calibration) – Ultra High Capacity Models	37
4.7.1 General	37
4.7.2 Accuracy Verification – Ultra High Capacity	37
4.7.3 Calibration Procedure – Ultra High Capacity	38
4.8 Pulley Alignment (Suction Pumps)	39
4.9 Belt Adjustment (Suction Pumps)	39
4.10 Compact Pumping Unit Adjustment	41
4.11 Fluorescent Lights	41
4.12 Voltage Test	42
4.13 Complete Installation	42
5 OPERATION	43
5.1 Safety Items You Should Know	43
5.1.1 Portable Tanks and Containers	44
5.1.2 Health Note	44
5.2 Dispenser Operation	44
5.3 Electromechanical Totalizers	45
5.4 Dispenser Statistics & Diagnostics	45
5.4.1 General	45
5.4.2 Password Protection	46
5.4.3 Viewing the Electronic Totalizers	47

Table of Contents (continued)

Title	Page
6 MAINTENANCE	51
6.1 Preventive Maintenance	51
6.2 Strainer/Filter – Standard/Enhanced Capacity and Super High Capacity	51
6.3 Filters – Ultra High Capacity Models	52
6.4 Cleaning and Corrosion Protection Instructions	52
6.5 Meter Maintenance Issues	53
6.6 Fluorescent Light Bulb Replacement	53
6.7 How to Get Service on Your Pump	53
 APPENDIX A - DIMENSIONS & BASE LAYOUTS	 55
3/G2201P/JK/W Single Suction Pump - Island	56
3/G2202P/JK Twin I Suction Pump - Island	57
3/G2207P/JK Twin I Suction Pump - Lane	58
3/G2203P/JK/W Twin II Suction Pump – Island	58
3/G2201D/GJK Single Remote Dispenser – Island	59
3/G2202D/GJK Twin I Remote Dispenser – Island	60
3/G2207D/GJK Twin I Remote Dispenser – Lane	60
3/G2203D/GJK Twin II Remote Dispenser – Island	61
3/G2221D/GJK Super High Capacity Single Remote Dispenser – Island	62
3/G2227D/GJKR Super High Capacity Single Remote Dispenser – Lane	62
3/G2227D/GJKMR Super High Capacity Single Master Remote Dispenser – Lane	63
3/G2228D/GJKLM Super High Capacity Single Master Remote Dispenser & Satellite Combination– Lane	64
3/G2227D/GJK Super High Capacity Twin I Remote Dispenser – Lane	65
3/G2227D/GJKM Super High Capacity Twin I Master Remote Dispenser – Lane	66
3/G2231D/GJK Ultra High Capacity Single Remote Dispenser – Island	67
3/G2237D/GJKMR Ultra High Capacity Single Master Remote Dispenser – Island	67
3/G2232D/GJK Ultra High Capacity Twin I Remote Dispenser – Island	68
3/G2237D/GJKM Ultra High Capacity Twin I Master Remote Dispenser – Lane	68
3/G2233D/GJK Ultra High Capacity Twin II Remote Dispenser – Island	69
3/G2238D/GJKM Ultra High Capacity Twin II Master Remote Dispenser – Lane	69
3/G2239D/GJKMR Ultra High Capacity Twin II Master Remote Dispenser Single-Sided – Lane	69
3/G2238D/GJKLM Ultra High Capacity Single Master Remote Dispenser & Satellite Combination – Lane	70
Side View (Nozzle Side) – All Century Models (except Satellites)	71
3/G2007/JKLR Single Satellite Dispenser - Lane	72
3/G2008/JKL Twin Satellite Dispenser - Lane	73
3/G2037/JKLR Ultra High Capacity Single Satellite Dispenser – Lane	74
3/G2038/JKL Ultra High Capacity Twin Satellite Dispenser - Lane	75
3/G2039/JKL Ultra High Capacity Twin Satellite Dispenser Single-Sided - Lane	75

Table of Contents (continued)

Title	Page
APPENDIX B – ELECTRICAL RATINGS & WIRING DIAGRAMS	77
Electrical Ratings	77
3/G2201P/JK/W Single Suction Pump - Island	78
3/G2207P/JKR/W Single Suction Pump - Lane	78
3/G2202P/JK Twin I Suction Pump - Island	78
3/G2207P/JK Twin I Suction Pump - Lane	78
3/G2203P/JK/W Twin II Suction Pump – Island	79
3/G2201D/GJK Single Remote Dispenser – Island	80
3/G2202D/GJK Twin I Remote Dispenser – Island	80
3/G2207D/GJK Twin I Remote Dispenser – Lane	80
3/G2221D/GJK Super High Capacity Single Remote Dispenser – Island	80
3/G2227D/GJKR Super High Capacity Single Remote Dispenser – Lane	80
3/G2227D/GJK Super High Capacity Twin I Remote Dispenser – Lane	80
3/G2203D/2GJK Twin II Remote Dispenser – Island	81
3/G2227D/GJKMR Super High Capacity Single Master Remote Dispenser – Lane	82
3/G2227D/GJKM Super High Capacity Twin I Master Remote Dispenser – Lane	83
3/G2228D/GJKLM Super High Capacity Single Master Remote Dispenser & Satellite Combination– Lane	84
3/G2231D/GJK Ultra High Capacity Single Remote Dispenser – Island	85
3/G2237D/GJKMR Ultra High Capacity Single Master Remote Dispenser – Lane	85
3/G2232D/GJK Ultra High Capacity Twin I Remote Dispenser – Island	86
3/G2237D/GJKM Ultra High Capacity Twin I Master Remote Dispenser – Lane	86
3/G2233D/GJK Ultra High Capacity Twin II Remote Dispenser – Island	86
3/G2238D/GJKM Ultra High Capacity Twin II Master Remote Dispenser – Lane	86
3/G2239D/GJKM Ultra High Capacity Twin II Master Remote Dispenser - Lane, Single-Sided	87
3/G2238D/GJKLM Ultra High Capacity Single Master Remote Dispenser & Satellite Combination– Lane	88

Table of Contents (continued)

Title	Page
APPENDIX C – DISPENSER SOFTWARE CONFIGURATION, STATISTICS, & DIAGNOSTICS. 89	
C.1 General	89
C.2 Entering Functions and Statistics	89
C.3 IRC Commands	90
C.4 Changing Sub-function Values	91
C.5 Resetting Totals	92
C.6 Exiting Functions	92
C.7 Exiting Statistics	92
C.8 Quick Exit from Functions and Statistics	93
C.9 Dispenser Side & Nozzle Identification	93
C.10 List of Statistics	95
C.11 Meter Number Assignments	98
C.12 Generic Configuration Functions	98
C.13 Configuration Sub-Function Detail Settings for Non-UHC Models	109
C.14 Configuration Sub-Function Detail Settings for UHC Models	110
C.15 Configuration Sub-Function Detail Settings for Non-UHC Models	111
APPENDIX D – LOCAL AUTHORIZE / STANDALONE OPERATION 115	
D.1 General	115
D.2 Placing the Dispenser into Standalone Operation	116
APPENDIX E – WEIGHTS & MEASURES MODE & TEMPERATURE COMPENSATION 119	
E.1 Weights & Measures Mode	119
E.2 Weights & Measures Mode – Temp Comp Data	123
E.3 Temp Comp Fueling Mode	124
APPENDIX F – ERROR CODES 125	
Error Code List	125
APPENDIX G – Internal Wiring & Connectors 129	
G.1 Internal wiring – CPU (Non UHC models).....	129
G.2 Internal wiring – CPU (UHC models)	130
G.3 Internal wiring – Displays	131
G.4 Internal wiring – Power for Remote Dispensers	132
G.5 Internal wiring – Power for Suction Pumps	133
G.6 Internal wiring – Connectors	134

1 INTRODUCTION

1.1 Dispensers Covered

This manual describes the installation and operation of the Wayne Century Series Electronic Registration Fleet Dispensers. Wayne Century dispensers are designated by the 3/G2200 model number series. Model descriptions are shown in Section 1.2. The model number suffix designations are defined in Section 1.3.

Century dispensers may be installed and operated as a stand-alone unit, or as component part of a Wayne Management control system, or they may be controlled by a third party fuel control system. This manual provides installation and operation information for Century dispensers operating as stand-alone units. Information concerning Wayne control systems has been included where appropriate in this manual, however, for complete installation and operation of the control system, refer to the manuals provided with the control system. It is also necessary to consult the applicable third party fuel control system documentation for installation and operation information and any necessary safeguards and warnings, for interfacing to a third party system.

Any questions concerning the installation and operation of the dispensers that are not covered in this manual should be referred to your authorized Wayne service personnel or Wayne Technical Support (1-800-926-3737).









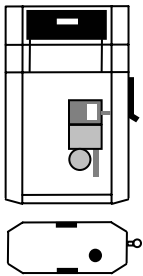
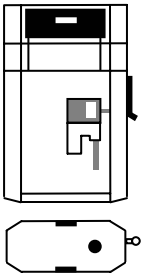
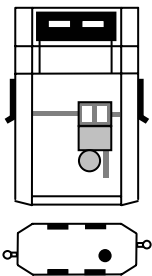
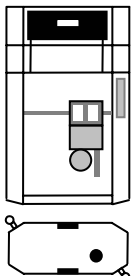
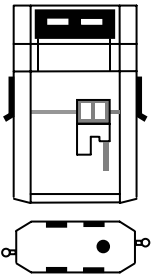
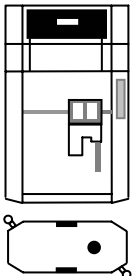
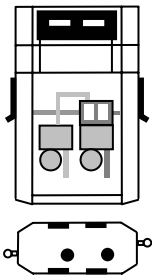
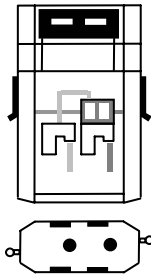





NOTE: Terminology Used in This Manual

Dispenser(s):	Generic term used to refer to <u>any</u> model in the Wayne Century Series.
Suction Pump(s):	Models with self-contained pumping units installed in the dispenser hydraulic cabinet.
Remote Dispenser(s):	Models utilizing a submersible pump in the tank to provide fuel to the dispenser.
Satellite Dispensers:	Models that do not have their own meter, pumping units, or displays. Satellite hoses are supplied product from a "master" remote dispenser and provide an additional fueling point for that dispenser. Any fuel dispensed from the satellite hose is registered on the master dispenser to which it is connected. Satellite dispensers are typically mounted on the opposite side of the fueling lane from the related master dispenser to simplify filling vehicles with saddle tanks.
Standard/Enhanced Capacity:	Suction pump and remote dispenser models with one Wayne iMeter measuring chamber per hose. Standard Capacity units have a 3/4" outlet. Enhanced Capacity units have a 1" outlet.
Super High Capacity (SHC):	Remote dispenser models with two Wayne iMeter measuring chambers per hose for increased flow performance.
Ultra High Capacity (UHC):	Remote dispenser models using a Liquid Controls® meter per hose for maximum flow performance.

1.2 Model Description

1.2.1 Standard/Enhanced Capacity Models (/2 for Enhanced Capacity)

TYPE	SUCTION PUMPS		REMOTE DISPENSERS	
	Island-Oriented	Lane-Oriented	Island-Oriented	Lane-Oriented
Single One Hose, One Product	3/G2201P/JK/W 		3/G2201D/GJK 	
Twin I Two Hoses, One Product	3/G2202P/JK 	3/G2207P/JK 	3/G2202D/GJK 	3/G2207D/GJK 
Twin II Two Hoses, Two Products	3/G2203P/JK/W 		3/G2203D/GJK 	

KEY – Front View	KEY – Base Layout View
 Display	 Display
 Duplex Meter (1 meter used)	 Nozzle Boot
 Duplex Meter (both meters used)	 Dispenser Inlet
 Suction Pump and Motor	 Satellite Inlet
 Strainer/Filter Assembly	 Satellite Outlet
 Piping (inlet or discharge)	
 Satellite Solenoid Valve	
 Nozzle Boot (island)	
 Nozzle Boot (lane)	

On front view, AC junction box is on the opposite side than the view shown.

1.2.2 Super High Capacity Models

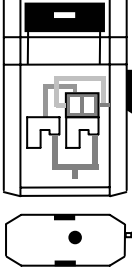
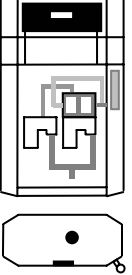
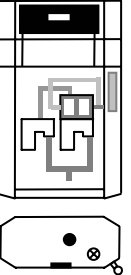
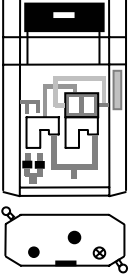
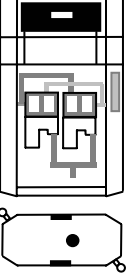
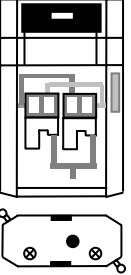
TYPE	STANDALONE		MASTER	MASTER/ SATELLITE*
	Island-Oriented	Lane-Oriented	Lane-Oriented	Lane-Oriented
Single One Hose*, One Product	3/G2221D/GJK 	3/G2227D/GJKR 	3/G2227D/GJKMR 	3/G2228D/GJKLM 
	Twin I Two Hoses, One Product		3/G2227D/GJK 	3/G2227D/GJKM 

*Note: The Master/Satellite has a single master dispenser and a single satellite dispenser housed in the same cabinet. There is a lane-oriented nozzle on one side for the master and a lane-oriented nozzle on the other side for the satellite dispenser.

1.2.3 Super High Capacity Satellite Dispenser Models

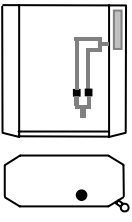
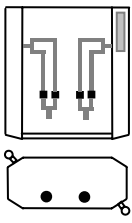
TYPE	Lane-Oriented
Single One Hose, One Product	3/G2007/JKLR 
Twin Two Hoses, Two Products	3/G2008/JKL 

KEY – Front View	KEY – Base Layout View
Display	Display
Duplex Meter (1 meter used)	Nozzle Boot
Duplex Meter (both meters used)	Dispenser Inlet
Suction Pump and Motor	Satellite Inlet
Strainer/Filter Assembly	Satellite Outlet
Piping (inlet or discharge)	
Satellite Solenoid Valve	
Nozzle Boot (island)	
Nozzle Boot (lane)	

On front view, the AC junction box is the opposite side than the view shown.

1.2.4 Ultra High Capacity Dispenser Models

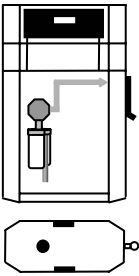
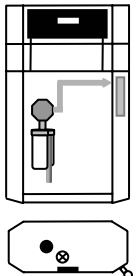
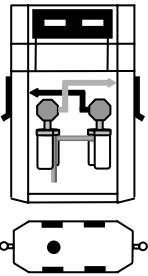
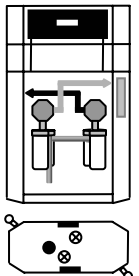
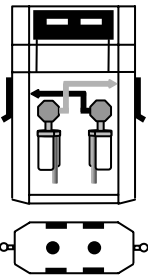
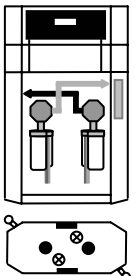
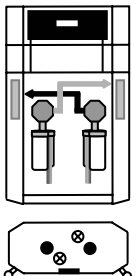
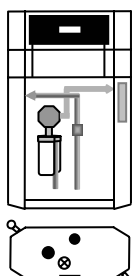
TYPE	UHC REMOTE DISPENSERS		
	Island-Oriented	Lane-Oriented	Lane-Oriented, 2 Nozzles Same Side (single-sided)
Single One Hose, One Product	3/G2231D/GJK 	3/G2237D/GJKMR 	N/A
Twin I Two Hoses, One Product	3/G2232D/GJK 	3/G2237D/GJKM 	N/A
Twin II Two Hoses, Two Products	3/G2233D/GJK 	3/G2238D/GJKM 	3/G2239D/GJKMR 
Combo Single & Satellite Two Hoses, Two Products	N/A	3/G2238D/GJKLM 	N/A

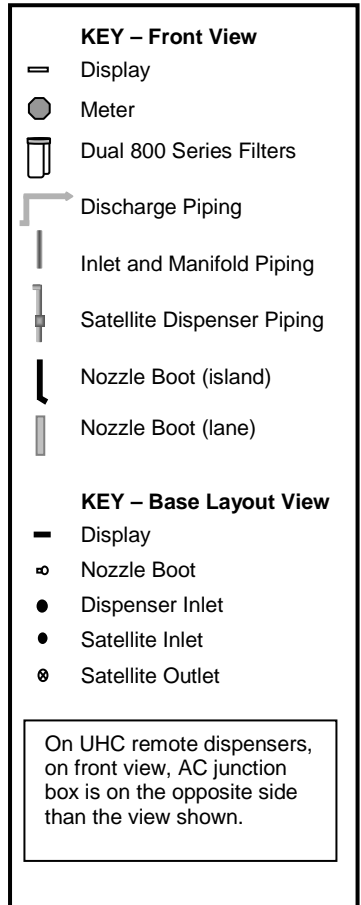



Note: All UHC models may be piped and wired as master dispensers with satellites; however, only lane-oriented models are recommended for use as masters so there is a clear correlation between which master and satellite nozzles go together.

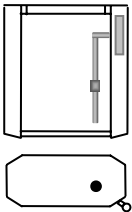
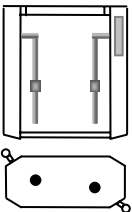
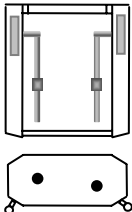

1.2.5 Ultra High Capacity Satellite Dispenser Models

TYPE	UHC SATELLITES	
	Lane-Oriented	Lane-Oriented, 2 Nozzles Same Side (single-sided)
Single One Hose, One Product	3/G2037/JKLR 	N/A
Twin I Two Hoses, Two Products	3/G2038/JKL 	3/G2039/JKLR 

KEY – Front View

-  Satellite Dispenser Piping
-  Nozzle Boot (lane)

KEY – Base Layout View

-  Nozzle Boot
-  Satellite Inlet

On satellite dispensers, on front view, AC junction box is on the same side as the view shown.

1.3 Model Designation Format

Prefix / Main Body / First Suffix / Second Suffix
 X / ABCDEF / ZZZZZZZZ / YYYYYYYYYY

Prefix	X	Electronic & Hydraulic Configuration	3	iGEM
	/			
Main Body	A	Model Series	G	Global
			B	Century
	C	Model Style	0	Satellite Cabinet
			2	Column Style
	D	Flow Rate Capacity	0	Standard & High Capacity
			2	Super High Capacity
			3	Ultra High Capacity
	E	Hoses, Products, & Nozzle Configuration	1	One Hose, One Product, Island-Oriented Nozzle
			2	Two Hoses, One Product, Island-Oriented Nozzles
			3	Two Hoses, Two Products, Island-Oriented Nozzles
			7	Two Hoses (One Hose w/ "R" suffix), One Product, Lane-Oriented Nozzle(s)
			8	Two Hoses, Two Products, Lane-Oriented Nozzles
	F	Hydraulic System	D	Remote Dispenser
			P	Suction Pump
	/			
First Suffix		Additional Model Designators	L	Satellite – Super & Ultra High Capacity Models
			M	Master – Super & Ultra High Capacity Models
			R	Single-Sided Lane-Oriented Model
	Z	Standard	2	Enhanced Capacity (1" discharge. This suffix is not used on Super or Ultra High High Capacity models.)
			G	Internal Filter (Remote disps. only – n/a on suction models)
			J	Explosion-Proof AC Junction Box
			K	Hose Hanger (eliminated w/ hose retractor & mast options)
			C	Automatic Temperature Compensation-Non UL
	Z	Options	D3	HealyVac, Single or Twin-One Side
			D4	HealyVac, Twin with Both Sides
			H	Pulser Output Board (Canada only)
			I	Satellite "In Use" Indicator
			O	No EMT's-Electronic Totals Only
			S1	Preset-12 Button-Shared Functions w/ Sales Display
			S2	Preset-5 Button-Shared Functions w/ Sales Display
			S3	Preset-ADA 12 Button-Shared functions w/ Sales Display
			Z	240VAC Operation of Electronic Register and Light

	/		
			H Internal Hose Retractor
			I ISM-DART-Default is US Current Loop
			I2 ISM-DART/IFSF-Default is US Current Loop
			J Hose Mast
			K Electromechanical Totalizer Per Hose (Only applicable on Standard/Enhanced Capacity Twin I models. EMT per hose is std. on all other models.)
			W No Solenoids-Suction Only, No Preset

1.4 Technical Information

Application:	For dispensing low viscosity petroleum fuels - diesel, including biodiesel blends up to 20%; kerosene; gasoline, including standard oxygenated blends - from aboveground or underground storage tanks in applications where only volume measurement is required.
Performance:	<p>Standard Capacity: Up to 15 GPM (57 LPM) maximum test rate at discharge outlet. Twin I suction pump model is 15 GPM (57 LPM) per one hose operating, or 10 GPM (38 LPM) per hose with both operating.</p> <p>Enhanced Capacity: Up to 22 GPM (83 LPM) maximum test rate at discharge outlet. Twin I suction pump model is 22 GPM (83 LPM) per one hose operating, or 12 GPM (45 LPM) per hose with both operating.</p> <p>Super High Capacity (SHC): Up to 36 GPM (136 LPM) maximum test rate at discharge outlet. For Twin I SHC model, maximum test rate is with one hose operating at a time.</p> <p>Ultra High Capacity (UHC): Up to 60 GPM (227 LPM) maximum test rate at discharge outlet (based on total of both Master & Satellite hoses in use at same time).</p> <p>Important: Actual flow rates will depend upon the installation conditions, product dispensed, dispenser accessories, and for remote dispensers, the size of the submersible pump.</p>
Electronic Head:	Wayne iGEM electronics platform. Controls dispenser operation. Provides user operating messages, transaction limit controls, error monitoring, enhanced diagnostics. Allows software uploads/downloads via a PC. Infrared remote control allows configuring settings, reading totalizers, and accessing diagnostic tools. 120/240VAC 50/60 Hz operation. (Note: Light is only 120 VAC std. - 240VAC option required for 240VAC operation.)
Liquid Crystal Displays:	Backlit 1" (2.5 cm) six-digit Volume and Total \$ displays and ½" (1.3 cm) four-character Unit Price display per hose. Displays each side of cabinet, except models with lane-oriented nozzle boots only display on corresponding nozzle boot side. Configurable 0-4 digits to right of decimal. Programmable gallons or liters. In event of power loss, remain visible for approximately 15 minutes.
Totalizers:	7-digit electromechanical non-resettable totalizer per product. One non-resettable and one resettable electronic 6-digit totalizer per hose. Electronic totalizers display on volume display by using infrared remote control.
Light:	Light in electronic head provides backlighting for liquid crystal displays and illuminates product identification panels. 120VAC 60 HZ operation. Optional 240VAC 50/60 Hz operation.
Fuel Control System Interfaces:	Wayne dispenser protocol.
Meter:	Standard/Enhanced Capacity and Super High Capacity Models: Wayne 2-piston, positive displacement iMeter with integral intelligent pulser. Electronic calibration. Ultra High Capacity Models: Liquid Controls M-5 positive displacement rotary meter with Wayne optical pulser. Electronic calibration.
Pumping Unit:	Suction pump models. Wayne Compact Pumping Unit (CPU). Belt-driven, positive displacement rotary gear pump with integral centrifugal air separator. Not available on SHC and UHC Models.
Motor:	Suction pump models. 1 HP, continuous duty motor. 120/240VAC, 50/60 Hz, with thermal overload. Adjustable V-link belt connects to the pump pulley.

Junction Boxes:	Explosion-proof AC junction box standard for electronic head, light, suction pump, and submersible connections.
Strainer:	Standard/Enhanced Capacity and Super High Capacity Models: 120-mesh; removable for cleaning. Ultra High Capacity Models: No strainer is provided. See filter section. Disposable strainer canisters are available as an option to replace the internal filters.
Filter:	Standard/Enhanced Capacity and Super High Capacity Models: Internal filter adapter with 30-micron particulate filter element (remote dispenser models only). Ultra High Capacity Models: Two internal Cimtek Series 800 filters (40 GPM each) per hose with 30-micron particulate filter elements. (Note: User should make sure the filter element meets the application and replace with the appropriate element as necessary.)
Flow Control Valve:	Standard/Enhanced Capacity and Super High Capacity Models: Proportional 7/8" (2.2cm) 24V valve. Standard on remote dispensers and Twin I suction model. Optional on other suction models. Ultra High Capacity Models: Proportional 1-1/2" (3.81cm) 24V valve.
Inlet:	Standard/Enhanced Capacity Models: 1 1/2" (3.8cm) male NPT. Super High Capacity Models: 1 1/2" (3.8cm) male or 2" female (5.1cm) NPT. Ultra High Capacity Models: 2" (5.1cm) male NPT.
Outlet:	Standard Capacity Models: 3/4" (1.9cm) female NPT. Enhanced Capacity and Super High Capacity Models: 1" (2.5cm) female NPT. 3/4" (1.9cm) reducing bushing supplied for 3/4" hose assemblies on non-SHC models. Outlet for satellite on Master configurations is 1-1/2" NPT. Ultra High Capacity Models: 1-1/4" (3.2cm) female NPT. 1" (2.5cm) reducing bushing supplied for 1" hose assemblies. Outlet for satellite on Master configurations is 1-1/2" NPT.
Cabinet:	Galvannealed metal. Hinged front and rear doors.
Finish:	Light Gray powder coat finish. Doors can be ordered as blue, black, green, red, yellow, silver, or white powder coated. Special paint and Stainless Steel doors available as an option.
Nozzle Boot and Hook:	Fits standard U.L. interchangeable automatic nozzles. Balanced vapor recovery nozzles: Emco Wheaton A4015 short spout and Husky V short spout. ORVR & EVR nozzles: Healy 600G, 800 & 900 series.
Options:	External filter kit (suction models), hose mast, internal hose retractor, and 240VAC 50/60 HZ operation of the electronic head.
Hose and Nozzle Accessories:	Not included.
Approvals:	Underwriter's Laboratories UL Listed. FCC certified. Sealable by U.S. Weights & Measures for the resale of fuel with contracted periodic billing of fuel dispensed.

2 SITE DESIGN & PREPARATION

2.1 Local, State, and Federal Codes

The Wayne Century Series models are only part of a fuel dispensing system. A fuel dispensing system typically comprises equipment and safety devices from a variety of manufacturers. It is the responsibility of the dispenser owner to have a qualified installer ensure that all of the necessary equipment and accessories are included to meet the requirements of the application and all tanks (both underground and aboveground), piping and fittings, check valves, leak detection and corrosion protection devices, wiring, venting systems, filtration devices, safety valves, submersible pumps, etc., are installed in accordance with the manufacturer's instructions and in compliance with local and regional building codes and requirements pertaining to private fueling facilities (or other locations where the dispenser may be installed).

These requirements may include references to the National Electrical Code (NFPA 70); Automotive and Marine Service Station Code (NFPA 30A); Flammable and Combustible Liquids Code (NFPA 30); Code of Federal Regulations, Title 40, Section 280 (40 CFR 280); United States Environmental Protection Agency (U.S. EPA) Technical Regulations of 9-23-88 and U.S. EPA Financial Responsibility Regulations of 10-26-1988.

Where local requirements do not specify applicable codes, Wayne recommends using the codes listed above. These codes are comprehensive and detailed, often requiring interpretation to cover unusual situations, and, therefore, the associated handbooks (where applicable) should also be consulted. (The handbooks are also available from the same sources.)

Due to the variety of locations encountered, further information on installation cannot be dealt with in this document except as the codes relate directly to the installation of the dispenser. Therefore, it is strongly recommended that a qualified engineer or contractor familiar with local regulations and practices be consulted before starting installation.

Pertinent information and codes are available from the following sources:

Association for Composite Tanks (ACT)

North State Street
Suite 720
Chicago, IL 60602
(301) 355-1307 (for information requests)

American Petroleum Institute (API)

1220 L Street, N.W.
Washington, DC 20005
(202) 682-8000

Fiberglass Petroleum Tank and Pipe Institute

One SeaGate, Suite 1001
Toledo, OH 43604
(419) 247-5412

National Assoc. Corrosion Engineers

(NACE)
Box 218340
Houston, TX 77218
(713) 492-0535

National Fire Protection Association (NFPA)

One Batterymarch Park
Quincy, MA 02269-9101
(617) 770-3000

National Leak Prevention Association

(NLPA)
685 Fields Ertel Road
Cincinnati, OH 45241
(513) 489-9844 or 1-(800) 543-1838

Petroleum Equipment Institute (PEI)

Box 2380
Tulsa, OK 74101
(918) 494-9696

Steel Tank Institute

P. O. Box 4020
Northbrook, IL 60065
(312) 498-1980

(continued on next page)

Underwriters Laboratories Inc.

333 Pfingsten Road
Northbrook, IL 60062
(312) 272-8800

Underwriters Laboratories of Canada

7 Crouse Road
Scarsborough, Ontario, Canada N1R3A9
(416) 757-3611

United States Environmental Protection Agency

Office of Underground Storage Tanks
401 M St., SW (05-400WF)
Washington, DC 20640
(703) 308-8850 (Underground Storage Tanks)

U. S. Department of Labor,

Occupational Safety and Health Administration (OSHA) Washington, DC 20402
• Call OSHA at (202) 523-8148 to determine specific needs; OSHA rules are covered by Title 29 of the Code of Federal Regulations (29 CFR.)
• Order OSHA publications from:
Government Printing Office (GPO)
Washington, DC 22304
(202) 783-3238

Western Fire Chiefs Association

5360 South Workman Mill Road
Whittier, CA 90601
(213) 699-0541

NOTE: Other regulatory codes may apply. Consult your local and regional code requirements to determine which codes are applicable for your location.

2.2 Safety Precautions

NFPA 30A states that:

“When maintenance to Class I dispensing devices becomes necessary and such maintenance is capable of causing the accidental release or ignition of liquid, the following precautions shall be taken before such maintenance is begun:

- Only persons knowledgeable in performing the required maintenance shall perform the work.
- All electrical power to the dispensing devices, to the pump serving the dispensing devices, and to all of associated control circuits shall be shut off at the main electrical disconnect panel.
- The emergency shutoff valve at the dispenser, if installed, shall be closed.
- All vehicular traffic and unauthorized persons shall be prevented from coming within 20 ft. (6 m) of the dispensing device.”¹



WARNING

Electric shock hazard! More than one disconnect switch may be required to de-energize the pump for maintenance and servicing. Use a voltmeter to make sure ALL circuits in the pump are de-energized. Failure to do so may result in serious injury.

Lockout/Tagout requirements of the U. S. Dept. of Labor, Occupational Safety and Health Administration (OSHA) may also apply. Refer to Title 29, Part 1910 of the Code of Federal Regulations (29CFR1910), *Control of Hazardous Energy Source (Lockout/Tagout)*.

1. Reprinted with permission from NFPA 30A, *Code for Motor Fuel Dispensing Facilities and Repair Garages 2000 Edition*, Copyright ©2000, National Fire Protection Association, Quincy MA 02269. This reprinted material is not the complete and official position of the National Fire Protection Association on the referenced subject, which is represented only by the standard in its entirety.

2.3 Existing Installations

- If the dispenser is to be installed on an existing installation, it is still the responsibility of the installer to read and follow this installation manual in its entirety and make sure the existing installation meets the requirements and satisfies local, state, and federal codes.

2.4 Island Construction, Dispenser Anchoring, and Piping

- A concrete foundation must be provided for the dispenser. Do not pour concrete around product lines or electrical conduit risers. Allow for the proper dispenser containment box if required by local, state, or federal regulations. Reference Appendix A, Dimensions & Base Layouts, for dispenser dimensions.
- Anchor bolts pre-set in the concrete, or concrete anchors driven into the concrete, must be used to securely bolt the dispenser to the island in accordance with NFPA requirements. The base of the dispenser contains two bolt holes for anchoring the dispenser to the island. If anchor bolts are used, position the anchor bolts in accordance with the dimensions given on the appropriate Dimensions & Base Layout drawing in Appendix A.
- Vertical supply risers and electrical conduits must be located per the Installation Drawing for the appropriate model. Proper height must be maintained to avoid undue stress on the dispenser. See Section 3.3 for wiring and conduit requirements. Reference Appendix B for Wiring Diagrams.
- Supply piping should be selected and installed based on the product dispensed and in accordance with local, state, and federal regulations. The piping manufacturer's instructions should be followed for the proper trenching, connection, sealing, corrosion prevention, pressure relief, leak detection, containment, and testing.
- Supply lines should extend a minimum of 18" (46cm) straight down from the dispenser (more in hot climates and high altitudes to prevent product vaporization) and then slope downwards to the tank at approximately 1/4" per foot (1cm drop per 48cm run). Be sure there are no traps and minimize the number of bends and elbows.
- Standard/Enhanced Capacity models: If the distance from the dispenser to the tank is 60 feet (18.2m) or less, 1½-inch (3.8cm) schedule 40 pipe may be used. For distances greater than 60 feet (18.2m), 2-inch (5.1cm) schedule 40 pipe is recommended to lessen friction.
- Super High Capacity and Ultra High Capacity models: minimum 2-inch (5.1cm) schedule 40 pipe is recommended to provide the maximum flow rate.

2.5 Suction Pump Installations

2.5.1 Suction Pumps - General

- To maximize flow and minimize product vaporization (gasoline), position the suction pump dispenser and the tank as close together as possible, minimize the number of turns in the supply piping, and minimize the vertical lift. The vertical lift is limited by the properties of the product being dispensed [dynamic lift: gasoline – approx. 12 feet (3.6m); diesel – approx. 13 feet (4m)]. The maximum lift will vary depending upon product temperature and installation conditions.
- It is recommended that the vent line from the air separator be piped back to the storage tank. The return line should be at least ½” (1.3cm).

2.5.2 Suction Pumps With Aboveground Storage Tanks (ASTs)

- If the suction pump is used with an AST (mounted below the product level in the tank), the installer must provide the necessary safety valves according to the local, state, and federal codes. These valves include, but may not be limited to, an emergency block valve in the piping immediately after it exits the tank followed by an electrically operated solenoid valve for anti-siphon. A vacuum-actuated valve (pressure regulator valve) with shear section, or equivalent valve, must be installed beneath the pump. All valves must be equipped with a pressure relief mechanism. Pressure in the pump cannot exceed 50 psi.
- Suction pumps used with an AST must use a 2.5mm pipe plug orifice (PN 129881) in the Compact Pumping Unit (CPU) to reduce the possibility of fluid coming out through the vent pipe under certain extreme conditions. Directions for inserting the pipe plug orifice into the CPU are shown below:
 - Remove the two bolts from the air separator tube end cap
 - Place the pipe plug orifice on the end of a 3/16” T-handle allen wrench with 7” minimum length shaft (a 3/16” hex head on the end of a socket extension may also be used)
 - Thread the pipe plug orifice into the far end of the air separator tube
 - Replace the end cap and secure with the two bolts



WARNING

For suction pumps installed with aboveground tanks, or with a booster pump, a Listed¹, vacuum-actuated shutoff valve with a shear section or equivalent-type valve shall be installed directly under the dispensing device. Failure to install the proper shutoff valve will present a hazardous condition that could result in serious injury and/or environmental damage.

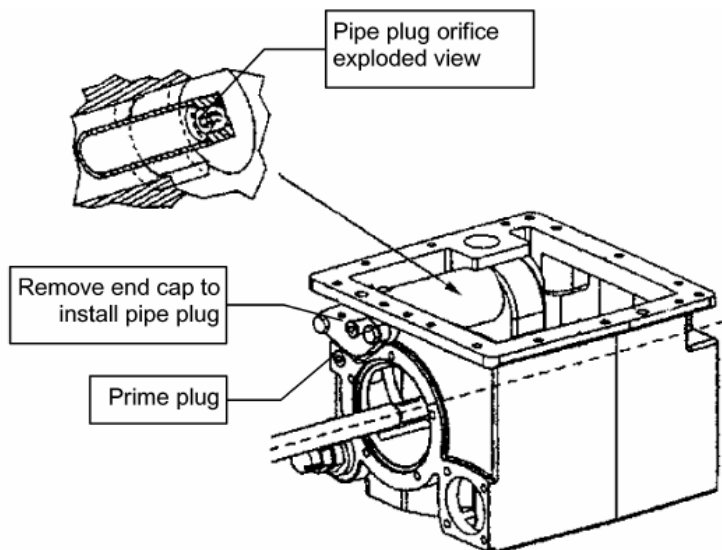

¹ “Listed” means published on a list by a nationally recognized testing laboratory (NRTL) which is responsible for product evaluation and is acceptable to the authority having jurisdiction. Underwriters Laboratories, Inc. is one example of a Nationally Recognized Testing Laboratory. For more information on NRTL’s, see Title 29, Parts 1907 and 1910 of the Code of Federal Regulations, Safety Testing or Certification of Certain Workplace Equipment and Materials.

2.5.3 Suction Pump Check Valves

- Suction pumps require a check valve in the product lines to stop the product from draining back into the tank. Only one check valve should be used per supply line and it should be installed directly below, and as close as practical, to the suction pump.

NOTE: All check valves must be equipped with pressure relief valves that ensure thermal expansion pressures in excess of 50 psi (345 kPA) are relieved back to the tank. A listed valve should be used.

- Spring-loaded valves and union check valves are not recommended as they are too restrictive and may cause erratic dispenser operations.
- Install the check valve according to the check valve manufacturer's directions.

2.5.4 Connecting More Than One Suction Pump to a Tank

- Wayne recommends only one suction pump be connected to a single suction line. If connecting multiple pumps to the same suction line is unavoidable, it is very important that a swing check valve be used in each suction line branch and that each valve be placed in the line as close as possible to the connection leading to the main suction line coming from the tank. This is necessary to prevent a pump from emptying the line leading to another pump instead of pulling the product out of the tank.

2.6 Remote Dispenser Applications

- To maximize flow, position the remote dispenser and tank as close together as possible and minimize the number of turns in the piping. Consult the submersible pump manufacturer for the proper sizing of the submersible pump, any necessary leak detection equipment, and installation details.
- Product piping must avoid the creation of vapor in the lines and deliver a minimum pressure of 25 psi at the remote dispenser inlet when all dispensers connected to the same submersible pump are operating. The dispenser's maximum operating pressure is 50 psi.



WARNING

For remote dispensers, a listed, rigidly anchored emergency shutoff valve must be installed, in accordance with the manufacturer's instructions, in each supply line at the base of each dispenser. For a typical emergency valve installation, see Figure 2-1. Failure to install the proper emergency shutoff valve will present a hazardous condition that could result in serious injury and/or environmental damage.

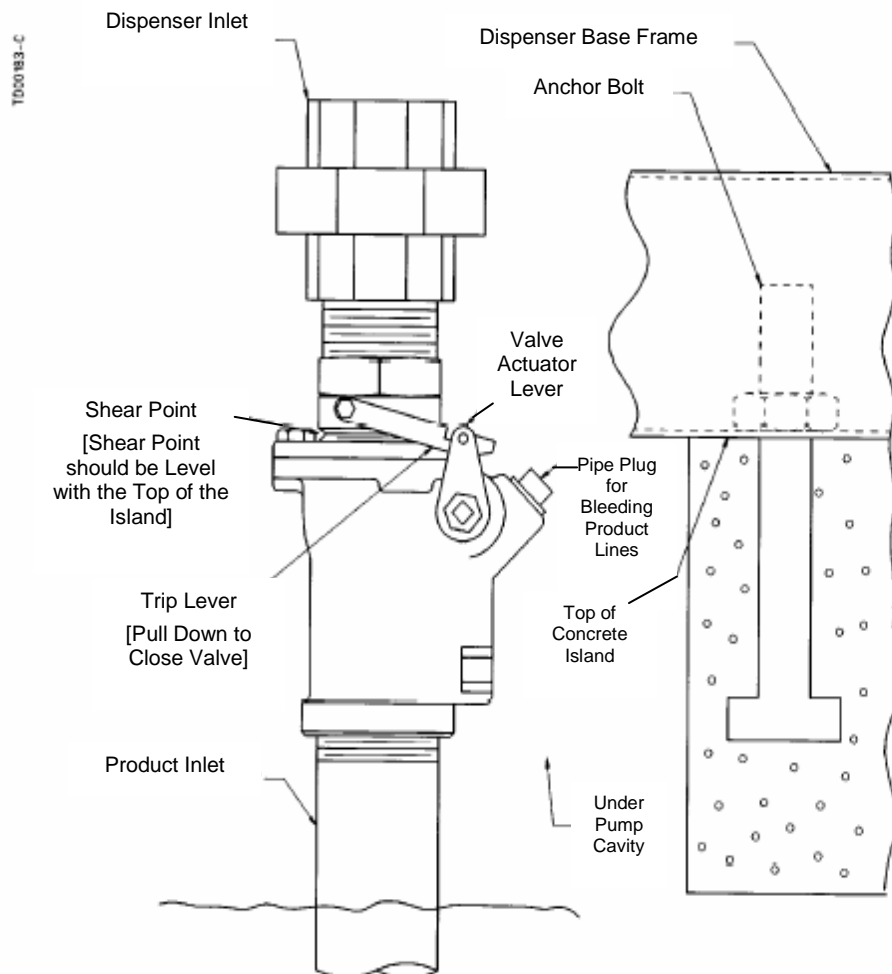

Figure 2-1 Typical Emergency Shutoff Valve Installation. *The emergency valve is designed to close the product line due to shock or fire. The shear section, shown above, functions if the dispenser is knocked out of position. Use the appropriate emergency valve to match the inlet piping.*

3 INSTALLATION

3.1 Equipment Inspection

- Examine the shipment immediately upon arrival to make certain there has been no damage or loss in transit. Make sure that all the component parts are accounted for, including keys and any optional equipment.
- Check and save the Packing Slip, Bill of Lading, Invoice, and all other documents included in the shipment.
- Damaged or lost equipment must be reported to the carrier. Any damage or loss that may occur in transit is not covered under the Dresser Wayne Warranty.

3.2 Lifting and Installing the Dispenser

- Step 1** The dispenser should have already been unpacked when the equipment was received and inspected in accordance with Section 3.1.
- Step 2** Unlock and remove the dispenser doors by removing screws on the bottom of the hinged doors, lift the doors straight up to clear the base, and then pull them forward.
- Step 3** Raise the dispenser up even with the island and slide the dispenser onto the island, or lower the dispenser over the anchor bolts. Position and securely bolt the dispenser to the island using the anchor bolts or use concrete anchors with minimum 3/8" thread and minimum 2½" depth (9.5mm x 64mm).



CAUTION

When handling the dispenser, lift only by the base or main chassis. Lifting by the nozzle boot, hose outlet, on/off lever, or any external panels, may result in dispenser damage and/or personal injury.

- Step 4** Remove the shipping plug from the dispenser inlet. Connect the product piping. To ensure tight, leak-proof piping connections, wash all cutting oils off the threads and use a UL-classified pipe joint sealing compound, rated for use with petroleum-based products.



WARNING

Explosive or flammable vapors may accumulate within the dispenser housing. All piping connections in the final installation must be accurately fitted and all threaded joints tightly made up with a Listed gasoline-resistant pipe joint compound. Put the compound on male threads only, being careful not to get excess inside the pipe or fittings. Failure to perform the above will present a hazardous condition that could result in serious injury.

3.3 Electrical Wiring

3.3.1 General

- Wayne recommends employing a qualified licensed electrician for all wiring.
- A hazardous liquid is being handled, so it is extremely important to ensure that all wiring and conduit are in accordance with all local, state and federal regulations, including, but not limited to, the National Electrical Code (NFPA 70), NFPA 30, and NFPA 30A.

NOTE: U.L. requires that all electrical connections to the dispenser be made with threaded, rigid conduit and properly sealed conductors. All dispensers and electrical connection boxes must be grounded per NFPA 70.

3.3.2 Electrical Termination Descriptions - All Dispensers

The following describes the standard electrical inputs and outputs utilized in the Wayne Century Series and can provide assistance in interpreting the Wiring Diagrams in Appendix B.

3.3.2.1 Ground

A good ground ensures proper operation of the equipment and provides the necessary safety factors. A ground wire must be connected between the unit's AC junction box ground lug and the main electrical service panel. One (1) earth ground connection is required per unit.

3.3.2.2 Control Power (Hot)

The control power (hot) is a 120VAC [international (int'l) - 240VAC] input for supplying power to the electronic register. The control power must have a dedicated breaker and must remain on all the time. The light power may share the same feed if you wish the light to remain on all the time (see light power below). For installations with multiple dispensers, up to twelve (12) dispensers can share the same breaker. If the control power and light power come from the same breaker, the maximum number of dispensers should be six (6) dispensers.

NOTE: When the dispenser is connected to a fuel control and/or tank monitoring system, they should be powered from the same circuit breaker panel so that they share a common neutral.

3.3.2.3 Control Power (Neutral)

The control power (neutral) is an AC return line from the electronic register to the breaker panel.

3.3.2.4 Light Power (Hot)

Light power (hot) is a 120VAC [int'l - 240VAC] input for powering the fluorescent light in the electronic head. For 240VAC applications, the proper options must be ordered to have compatible light ballasts. The lights can be powered from the control power breaker; however, by using a separate breaker from the control power, the light may be turned on/off while allowing the electronics to remain on all the time as required. For sites with multiple dispensers, the lights of up to twelve (12) dispensers can be connected to the same breaker if a separate breaker is used for the lights.

3.3.2.5 Light Power (Neutral)

Light power (neutral) is the AC return line from the lights to the breaker panel. When the control power and light power share the same breaker, the light power (neutral) and control power (neutral) can be connected together.

3.3.2.6 Motor Feed (Suction pump models)

The motor feed lines are either a 120VAC or 240VAC input for powering the suction pump motor. When running the motor at 240VAC make sure to change the switch on the motor to the 240VAC setting (see Section 3.3.5 Pump Motor Setting). Two (2) sets of feed lines are provided for twins. It is possible to combine the pump feeds for twins and supply them from one (1) breaker; however, the gauge of the wire needs to be adjusted to handle the load of the two (2) motors. This feed is controlled by the electronic register. After the display resets, the 120VAC or 240VAC input is switched to power the pump motor.

3.3.2.7 Aboveground Storage Tank (AST) Valve (Suction pump models)

The AST valve lines are used to control an electric solenoid that may be placed at the top of the tank if a suction pump dispenser is used with an AST. This electric solenoid valve is typically used as the required anti-siphon device for AST installations. These lines will be supplying power at the same voltage (120VAC or 240VAC) that is being used by the motor in the dispenser. Only one dispenser inlet can be connected to an electric solenoid valve. Current draw on these lines should be limited to one (1) amp.

3.3.2.8 Submersible Relay Control Output (Remote dispenser models)

The submersible relay control output provides 120VAC [int'l - 240VAC] for controlling a submersible starter relay. A relay is required to interface to the submersible pump. After the display resets, the electronic register supplies power on this line to close the submersible starter relay in order to activate the submersible pump. Two outputs are provided for twin units. In multiple dispenser applications, all dispensers operating the same submersible starter relay must be connected to the same main power circuit breaker. Up to twelve (12) submersible relay control output lines may be commoned at the starter relay. Where more than twelve (12) lines activate the same submersible pump, additional relays should be used and the contacts paralleled.

3.3.2.9 Data + & Data –

The data + and data – wires are used for interfacing the dispenser with a fuel control system using the Wayne dispenser serial protocol. For full details on the interconnections, reference the fuel control system installation manual.

3.3.3 Electrical Termination Descriptions – Master Dispenser Models

The following describes the additional electrical inputs and outputs associated with the satellite dispenser control in master dispenser models and can provide assistance in interpreting the Wiring Diagrams in Appendix B.

3.3.3.1 Satellite Handle

Satellite handle input(s) from the satellite dispenser inform the master dispenser of the on/off status of the satellite handle(s). Simultaneous or non-simultaneous operation of the master and satellite are controlled by the master dispenser’s electronic register and are set in the dispenser software configuration. Make sure that simultaneous operation of the master and satellite meets local, state, and federal codes.

The satellite handle terminology used in the wiring diagrams is defined below:

S1N4: Handle Sat 1	Handle input for Satellite 1 connected to Dispenser Side A. Satellite logical nozzle ID is 4. On the 3/G2239D/GJKMR, this line is used
S1N3: Handle Sat 1	Handle input for Satellite 1 connected to Dispenser Side A (Product B). Satellite logical nozzle ID is 3. Used only on 3/G2239D/GJKMR.
S2N4: Handle Sat 2	Handle input for Satellite 2 connected to Dispenser Side B. Satellite logical nozzle ID is 4.
ISB+: Handle Common	Common output to Satellite(s)' Intrinsic Safe Barrier(s) Handle Switch

3.3.3.2 Satellite Valve

Satellite valve outputs control the 24VDC solenoid valves in the satellite dispenser(s). For 3/G7007 & 3/G7008 SHC models, each satellite hose has two (2) valves to maximize flow. For 3/G7037 & 3/G7038 UHC models, each satellite has one (1) 1-1/2” valve for the highest throughput. The satellite valve terminology used in the wiring diagrams is defined below.

Single Master Dispensers (including Master/Satellite Combo and 3/G2239/MR)	
S1V9: Valve Sat 1	Valve control for first valve in Satellite 1 (SHC models) connected to Dispenser Side A. Valve # assignment is 9. For UHC singles, this is the only satellite control as there is only one valve in UHC satellites.
S1V10: Valve Sat 1	Valve control for second valve in Satellite 1 (SHC models) connected to Dispenser Side A. Valve # assignment is 10. On 3/G2239/MR models, this line is used to control Product B for Side A. Not used on all other UHC singles.
VAL: Valve Common	Common return from valves in Satellite 1.

Twin Master Dispensers	
S1V3: Valve Sat 1	Valve control for first valve in Satellite 1 (SHC models) connected to Dispenser Side A. Valve # assignment is 3. This is not used on UHC twins.
S1V9: Valve Sat 1	Valve control for second valve in Satellite 1 (SHC models) connected to Dispenser Side A. Valve # assignment is 9. For UHC models, this is the only satellite control line for Side A, as there is only one valve per side on the UHC satellite.
S2V7: Valve Sat 2	Valve control for first valve in Satellite 2 (SHC models) connected to Dispenser Side B. Valve # assignment is 7. This is not used on UHC twins.
S2V10: Valve Sat 2	Valve control for second valve in Satellite 2 (SHC models) connected to Dispenser Side B. Valve # assignment is 10. For UHC models, this is the only satellite control line for Side B, as there is only one valve per side on the UHC satellite.
VAL: Valve Common	Common return from valves in both satellites.

3.3.4 Circuit Breakers & Emergency Electrical Disconnect

- A primary requirement in dispenser installation wiring is to provide a means for disconnecting all power connections, including the neutral, to the dispensers for a safe shutdown and servicing of the units. The power to the electronic register (control power) should be on a separate dedicated breaker for each dispenser. No other equipment should be on this breaker. For sites with multiple dispensers, if it is not practical to use separate breakers for each dispenser, up to twelve (12) dispensers can be grouped together and tied to the same breaker. In multiple dispenser installations, all dispensers operating the same submersible starter relay must be connected to the same main power circuit breaker.
- The lights may share the same breaker as the electronic register only if you wish the lights to be on all the time. If the control power and lights are on the same breaker, the maximum number of dispensers on the same breaker is six (6).
- The motor feed must come from a separate breaker. Install the correct breaker size based upon the model and/or voltage setting. If two (2) pumps are handled from one (1) breaker, size the breaker to handle the total load of the two (2) motors.

Motor	120VAC 60 Hz	240VAC 60 Hz	240VAC 50 Hz
1 HP	12.4 Amps	6.2 Amps	7.3 Amps

NOTE: Twin suction models have two (2) motors except for the 3/G2202P/JK and 3/G2207P/JK Twin I models that have one (1) motor.

- A separate circuit breaker must be provided for each submersible pump.
- Both legs of any AC circuit must be broken.
- If a fuel control system and/or tank monitoring system are used with the dispenser, all should be powered from the same breaker panel so they can share a common neutral.



WARNING

In addition to the circuit breaker requirements, in accordance with local, state, and federal regulations, the fueling site should include a clearly identified emergency electrical disconnect switch that simultaneously removes power to all of the electrical equipment installed in the hazardous classified areas of the fuel site, including, but not limited to, the fuel dispensers, submersible pumps, and fuel control systems. The switch should be located within a convenient distance of the fueling equipment and all employees and fuel site users should be trained on the location and function of the emergency switch.

3.3.5 Pump Motor Voltage Setting (Suction Pumps)

- The standard Wayne Century Series motor may be set for 120VAC or 240VAC operation at 50/60 Hz. Make sure the motor setting matches the desired voltage to which the motor is wired. An improper voltage setting will cause damage to the motor.
- To check the motor operating voltage, locate the voltage plate and switch on the pulley side of the motor. The inscription next to the screw head indicates the current voltage setting of the motor: “LOW VOLTS” (120VAC) or “HIGH VOLTS” (240VAC).
- To change the operating voltage, loosen the screw. Place a flat-bladed screwdriver into the slot in the plate next to the voltage switch. Twist the screwdriver to turn the switch, so that the inscription of the desired voltage in the voltage plate is in line with the screw. Once the switch is in the desired position, re-tighten the screw.

3.3.6 Grounding

- All dispensers and electrical connection boxes must be grounded per NFPA 70.
- Connect a ground wire between the AC junction box ground lug and the main electrical service panel.
- Make sure a ground rod is properly installed and wired to the ground bus strip of the main electrical service panel in accordance with the National Electrical Code. Unless prohibited by local regulations, it is recommended that the neutral and ground bus strips be tied together.

3.3.7 Wiring

- All wiring should be UL-Listed, rated for a minimum 90⁰C (194⁰F), 600V, and gasoline and oil-resistant.
- All AC wire terminations must be made in the AC junction box. Take care when handling the junction box cover. Keep the mating flange clean and free of burrs and scratches. Make sure all wire connections are tightly spliced and secured with a wire nut. Use electrical tape to close the open end of the wire nut. After completing the wiring terminations, securely fasten the junction box cover using all of the supplied bolts. Make sure that any unused conduit entry openings are properly plugged.

3.3.7.1 Wire Size

- For suction pump models, the following table is provided as a guide for selecting the proper wire size for the motor feed and return lines based on the motor voltage. The feet/meters rows are the distance from the dispenser to the circuit breaker panel. If multiple pumps are powered from the same breaker and wires, the gauge of the wires must be increased taking into account the additional load and distance.

Recommended Wire Size (AWG) – 1 HP Motors							
Feet	25'	50'	100'	150'	200'	250'	300'
Meters	8m	15m	31m	46m	61m	76m	91m
120VAC	14	12	10	8	6	6	4
240VAC	14	12	12	10	10	10	8

- For remote dispensers, 14 AWG wire is recommended for most applications for the control lines to the submersible starter relay. The wire gauge for the submersible pump should be determined by the size of the motor and the length of the run according to the manufacturer's installation instructions.
- Wiring for the satellite control line must be 18 AWG.
- When the light is wired from a separate circuit breaker, the AC wire size for the light power hot and neutral lines should be 14 AWG for distances up to 300 feet (91m) or 12 AWG for distances over 300 feet (91m).

3.3.8 Conduit

- Use UL Listed threaded, rigid, metal conduit and properly sealed connectors. Threaded connections must be drawn up tight and have a minimum of five threads engaged.
- Do not use flexible conduit or knockout boxes.
- When connecting to a fuel control system, consult the manufacturer's instructions for conduit requirements for AC and DC lines.
- The following charts are provided as a guide to help determine the proper conduit sizes.

Step 1 Determine the square area for each wire by looking up the desired wire gauge below and writing down the corresponding square area from the Square Area column. Calculate the total area by adding the square area for each of the wires.

THHN/THWN Wire Areas				
Wire Gauge	Diameter		Square Area	
	in	mm	in ²	mm ²
18	.090	2.29	.007	4.1
14	.118	2.95	.011	6.8
12	.135	3.43	.014	9.2
10	.169	4.29	.022	14.5
8	.216	5.49	.037	23.7
6	.259	6.60	.053	34.2
4	.331	8.41	.086	55.5
3	.359	9.14	.102	65.6
2	.394	10.01	.122	78.7

Step 2 In the 25% Fill Area column below, find the square area that is closest to, without exceeding, the calculated total area. The value listed on the same row in the Trade Size Conduit column is the diameter of the required conduit.

Trade Size Conduit Square Area						
Trade Size Conduit	Internal Diameter		Square Area		25% Fill Area	
	in	mm	in ²	mm ²	in ²	mm ²
½"	.629	16	.303	196	.076	49
¾"	.826	21	.532	343	.133	86
1"	1.063	27	.862	556	.215	139
1 ¼"	1.378	35	1.50	968	.375	242
1 ½"	1.614	41	2.04	1314	.509	329
2"	2.087	53	3.36	2165	.839	541

NOTE: The calculated conduit size may need to be increased to allow for long runs or a large number of bends.

3.4 Hose and Accessories Installation

3.4.1 General

- Hose assemblies should be U.L. Listed and installed in accordance with the manufacturer's instructions.
- Install the hose assembly after the dispenser is installed.
 - To ensure a proper joint, wash all cutting oil off the threads and use a U.L. Listed gasoline-resistant pipe joint sealing compound.
 - Place the compound on male threads only; be careful not to get any excess compound on the inside of the fittings.
 - Install the fixed end of the hose to the dispenser outlet; secure according to the instructions of the sealing compound and hose manufacturer.
 - Install the nozzle, and other hose accessories – swivels, breakaways, etc. – on the hose according to the manufacturer's instructions.
- NFPA code requires a Listed emergency breakaway device, designed to retain liquid on both sides of the breakaway point, to be installed on each hose. These devices must be installed and maintained per the manufacturer's instructions. Refer to your state and local codes for breakaway device requirements that apply to your installation.



WARNING

Use only UL Listed hoses, nozzles, breakaways, and other hose accessories. Continuity must be present between the dispenser outlet and nozzle spout to prevent static discharge while fueling. Continuity must be checked for the outlet/hose assembly to insure that the nozzle is grounded. Failure to do so may result in a hazardous condition that could cause serious injury or death.

3.4.2 Vapor Recovery Nozzles

- The Select nozzle boot is approved for the Emco Wheaton A4015 short spout balance vapor recovery nozzle and the Husky V short spout balance vapor recovery nozzle.

4 START-UP

4.1 Initial Checkout

Verify the following items have been completed correctly and the installation meets the necessary local, state, and federal regulations as specified in Section 2.1.

- The dispenser is securely anchored to the fueling island.
- All conduit is rigid metal and is securely fastened. Do not seal the conduit until the wiring has been verified through proper operation.
- All wires are correctly routed and terminated, and the dispenser is properly grounded. Refer to the safety precautions in Section 2.2.
- All junction box covers are securely fastened with all of the supplied bolts and unused openings are properly plugged.
- The dispenser is equipped with the proper options and accessories to meet the application and satisfy local, state, and federal regulations. Refer to Section 6.2 regarding filter requirements.
- The hose and hose accessories are securely connected to the dispenser and have been checked for continuity.
- All water has been removed from the tank and the tank has a sufficient amount of fuel for testing.

NOTE: Do not use the 3/G2200 Series to remove water from the tank. It will harm the dispenser components.

To prevent damage to the components located in the hydraulic cabinet, dispenser doors should be closed during rainy and/or icy weather conditions.

4.2 Configuring the Dispenser Software

4.2.1 General

- The Century Series utilizes a very sophisticated electronics platform that offers a variety of controls, error monitoring, and diagnostics. The dispenser software configuration defines how the dispenser operates, what features are available, display formats, etc.
- The configuration settings are pre-loaded at the factory based upon the model and options. All that should be necessary is to verify the time and date settings, and if the pulse output interface option is installed, verify that the pulse ratio is set to the desired resolution.
- Appendix C contains a complete list of the dispenser functions and sub-functions and the default settings for each dispenser model should any other changes be required.

4.2.2 Making Configuration Changes

- The dispenser configuration and diagnostics can be accessed without opening the dispenser. The interface is handled through an infrared remote control (IRC). One IRC is shipped with each order of dispenser(s). To use the IRC, point it at the dispenser's liquid crystal displays from within a distance of a couple of feet and press the desired keys.
- Responses to the IRC commands are shown on the dispenser displays. Configuration function and sub-function numbers are shown in the Unit Price display and their corresponding values are shown in the Gallons/Liters display. Reference Figure 4-2.
- The configuration is password protected. To access the configuration and verify the time and date settings, follow the step by step instructions on the next page.

Note: The nozzle hook on/off lever must be in the "off" position to access the configuration.



Figure 4-1 Infrared Remote Control (IRC)

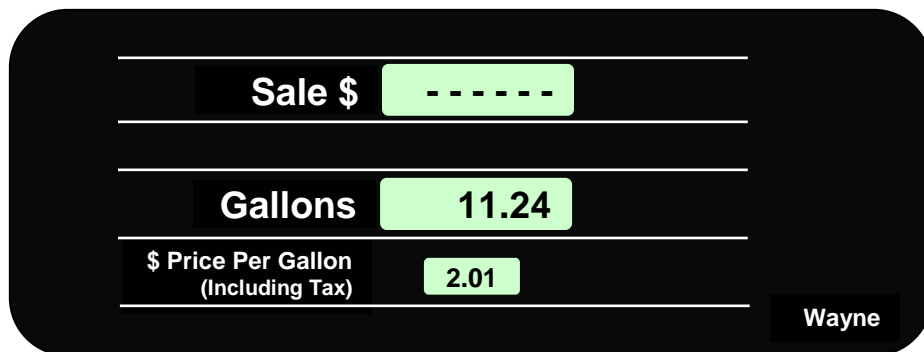

Figure 4-2 In this example, the unit price display shows subfunction 2.01 (date) with its value of 11.24 (November 24) shown in the Gallons display.

4.2.3 Configuration Start-Up

- The following steps will lead you through loading the most common features that need to be set according to the site configuration.

4.2.3.1 Sign on to the Dispenser

Enter Configuration Mode				
Step	IRC Command	Sale \$ Display	Volume Display	Unit Price Display
1 Service engineer sign on	Press <ENTER>	PASS 1	[blank]	[blank]
2 Enter default service engineer password	Type Password & Press <ENTER>	PASS 2	[blank]	[blank]
3 Re-enter default service engineer password	Type Password & Press <ENTER>	Software Version	Software Date	F --

4.2.3.2 Set the Date and Time

Change Time & Date				
4 Go to time & date function	Type<2> & Press <ENTER>	-----	[blank]	F 02
5 Go to time sub-function	Press <ENTER> again	-----	[time in HH.MM format] (if time is correct skip to step 8)	2.00
6 Clear display	Press <#>	[blank]	[time in HH.MM format]	2.00
7 Enter current time	Type the current time in the 24-hour format of HHMM & Press <ENTER>	-----	[entered time in HH.MM format]	2.00
8 Go to month/day sub-function	Press <NEXT>	-----	[date in MM.DD format] (if date is correct skip to step 11)	2.01
9 Clear display	Press <#>	[blank]	date in MM.DD format	2.01
10 Enter current month/day	Type the current date in the format of MMDD & Press <ENTER>	-----	[entered date in MM.DD format]	2.01
11 Go to year sub-function	Press <NEXT>	-----	[Year in YYYY format] (if the year is correct skip to step 14)	2.02
12 Clear display	Press <#>	[blank]	Year in YYYY format	2.02
13 Enter current year	Type the current year in the format of YYYY & Press <ENTER>	-----	[entered year in YYYY format]	2.02
14 Return to function level	Press <ENTER> again	-----	[blank]	F 02

4.2.3.3 Set the Correct Filling Mode of Operation

Dispensers are shipped configured for serial mode operation. This mode of operation is used when connected to an external control device. If this is the mode you plan to use for this dispenser, skip to step 20.

Set Filling Mode of Operation (Standalone or Serial Interface)				
Step	IRC Command	Sale \$ Display	Volume Display	Unit Price Display
15 Go to Set Filling Mode of Operation	Type<1> & Press <ENTER>	-----	[blank]	F 01
16 Go to Filling Mode sub-function	Press <ENTER> again	-----	[Filling Mode in X format, 1=Serial Mode, 2=Standalone mode]	1.00
17 Clear display	Press <#>	[blank]	[Filling Mode in X format, 1=Serial Mode, 2=Standalone mode]	1.00
18 Enter desired Filling Mode	Enter the desired Filling Mode, 1=Serial Mode, 2=Standalone Mode & Press <ENTER>	-----	[Filling Mode in X format, 1=Serial Mode, 2=Standalone mode]	1.00
19 Return to function level	Press <ENTER> again	-----	[blank]	F 01

4.2.3.4 Set the Fueling Point Address

Each hose must be set for a unique ID when used in the Serial Filling Mode of operation. Set the Fueling Point Address to the Hose Number that will be used to identify the hose. If this unit is set up for Standalone Filling Mode, skip to Step 30.

Set Fueling Point Address Side A (Serial Filling Mode Only) – Skip to Step 30 for Standalone Operation				
20 Go to Set Fueling Point Address-Side A	Type<5> & Press <ENTER>	-----	[blank]	F 05
21 Go to Set Fueling Point Address sub-function-Side A	Press <ENTER> again	-----	[Fuel Point address for Side A in X format]	5.00
22 Clear display	Press <#>	[blank]	[Fuel Point address for Side A in X format]	5.00
23 Enter desired Fueling Point Address (Hose number) for Side A	Type the desired Fueling Point Address for Side A & Press <ENTER>	-----	[New Fuel Point address for Side A in X format]	5.00
24 Return to function level	Press <ENTER> again	-----	[blank]	F 05
Set Fueling Point Address Side B (Serial Filling Mode Only) – Skip to Step 30 for Singles				
25 Go to Set Fueling Point Address-Side B	Type<6> & Press <ENTER>	-----	[blank]	F 06
26 Go to Set Fueling Point Address sub-function-Side B	Press <ENTER> again	-----	[Fuel Point address for Side A in X format]	6.00
27 Clear display	Press <#>	[blank]	[Fuel Point address for Side A in X format]	6.00
28 Enter desired Fueling Point Address (Hose number) for Side B	Type the desired Fueling Point Address for Side A & Press <ENTER>	-----	[New Fuel Point address for Side A in X format]	6.00
29 Return to function level	Press <ENTER> again	-----	[blank]	F 06

4.2.3.5 Load Prices

Dispensers with only one price display per hose will display and use the “Credit” price in Standalone mode. If the dispenser is controlled by a POS, Cash/Credit pricing may be used. The procedure below shows loading of both the Cash and Credit prices.

Load Price – Side A				
Step	IRC Command	Sale \$ Display	Volume Display	Unit Price Display
30 Go to set price function- Side A	Type<3> & Press <ENTER>	-----	[blank]	F 03
31 Go to Credit Price (Side A)	Press <ENTER> again	-----	[Current A credit price X.XXX)	3.01
32 Clear Price	Press <#>	[blank]	[Current A credit price X.XXX)	3.01
33 Enter new Credit Price	Type new price in the format of XXXX & Press <ENTER>	-----	[New A credit price X.XXX)	3.01
34 Go to Cash Price (Side A)	Press <NEXT>	-----	[Current A cash price X.XXX)	3.11
35 Clear Price	Press <#>	[blank]	[Current A cash price X.XXX)	3.11
36 Enter new Cash Price	Type new price in the format of XXXX & Press <ENTER>	-----	[New A cash price X.XXX)	3.11
37 Return for Function level	Press <ENTER>	-----	[blank]	F 03
Load Price – Side B – Skip to Step 40 for Singles				
38 Go to set price function- Side B	Type<4> & Press <ENTER>	-----	[blank]	F 04
39 Go to Credit Price (Side B)	Press <ENTER> again	-----	[Current A credit price X.XXX)	4.01
40 Clear Price	Press <#>	[blank]	[Current A credit price X.XXX)	4.01
41 Enter new Credit Price	Type new price in the format of XXXX & Press <ENTER>	-----	[New A credit price X.XXX)	4.01
42 Go to Cash Price (Side B)	Press <NEXT>	-----	[Current A cash price X.XXX)	4.11
43 Clear Price	Press <#>	[blank]	[Current A cash price X.XXX)	4.11
44 Enter new Cash Price	Type new price in the format of XXXX & Press <ENTER>	-----	[New A cash price X.XXX)	4.11
45 Return to function level	Press <ENTER> again	-----	[blank]	F 04

4.2.3.6 Exit and Save the Configuration

Exiting and Saving the Configuration				
46 Go to exit function	Type <0> and then Press <ENTER>	-----	[blank]	F 00
47 Go to exit sub-function	Press <ENTER> again	-----	1	0.00
48 Clear display	Press"##"	[blank]	1	0.00
49 Enter exit choice	Type the value of the exit choice below and then press <ENTER> (example shown is 3, exit and save) 1 = Do not exit & do not save changes 2 = Exit & do not save changes 3 = Exit & save changes	-----	3	0.00
50 Exit configuration	Press <ENTER> again	CHAnGE	StorEd	[Current Price]

4.3 Priming Suction Pumps

- Suction pumps must be primed before their initial operation. It is not advisable to run any type of internal gear pump dry during the priming process.
- The pumping unit can be primed from the top of the iMeter or from the top of the pumping unit top cover as applicable. Reference the figure below which is applicable to your model, and remove the corresponding cover and check valve, check valve assembly, or tube, and fill up the pumping unit with product before starting the pump for the first time.

Figure 4-3 Priming Single and Twin I Models

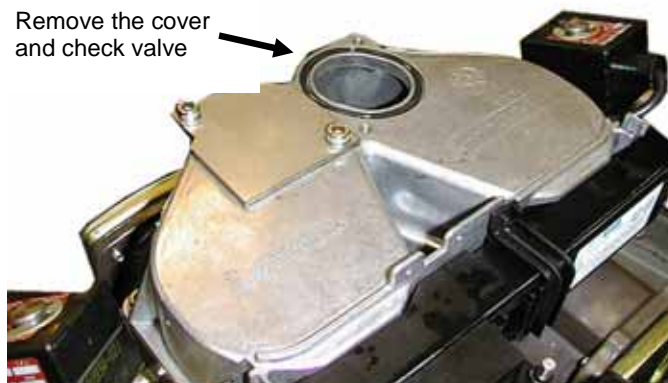
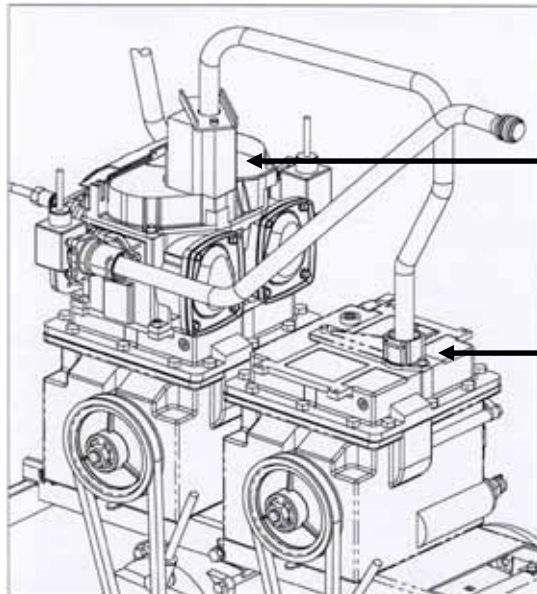

Figure 4-4 Priming Twin II Models



Remove the inlet check valve assembly and cage assembly plug on the one side of the duplex meter and the cover and check valve on the other side

Remove the tube by simply pulling the wire retaining clip out of the tube connector. The tube will then pull out of the connector. Be careful to not damage the o-ring.

4.4 Bleeding Product Lines (Remote Dispensers)

NOTE: To avoid severe damage to the dispenser, all air and air pockets must be bled from the product trunk lines before attempting to dispense product.

- Step 1** Make sure the power to the appropriate submersible pump is OFF.
- Step 2** To bleed air from the trunk line, remove the pipe plug from the safety impact valve on the dispenser that is farthest from the storage tank. For the pipe plug location, reference Figure 2-1 in Section 2.6.
- Step 3** Attach a flexible hose to the pipe plug opening in the safety impact valve and place the other end into a test can. Energize the appropriate submersible pump and allow the air to bleed out of the trunk line into the test can until product flows into the test can. De-energize the submersible pump and replace the pipe plug.
- Step 4** Repeat the procedure for each product and each trunk line.

4.5 Initial Delivery

After verifying the items in Section 4.1 through Section 4.4 have been completed, operation of the dispenser can be checked.

- Step 1** Turn on the circuit breaker(s) for the dispenser and, if applicable, the submersible pump.
- Step 2** If the dispenser is connected to a fuel control system, the dispenser must be authorized.
- Step 3** Remove the nozzle from the nozzle holder, and lift the on/off nozzle hook upward to turn the dispenser on. Make sure the Volume and Total Sale displays reset to zero.
- Step 4** Dispense fuel into a test can. Check all piping and hose connections to make sure there are not any leaks.
- Step 5** Turn the dispenser off by lowering the on/off nozzle hook to the down “off” position. Return the nozzle to the holder.
- Step 6** Repeat Steps 1 – 5 for each dispenser and both sides of twin dispensers.

4.6 Meter Check (Calibration) – Standard/Enhanced Capacity & Super High Capacity **Note:** Reference section 4.7 for UHC models

4.6.1 General

- Century dispensers (other than the Ultra High Capacity models) use the intelligent iMeter to measure the fuel dispensed. Each iMeter module can contain up to two meters. One meter is used per hose, except in the super high capacity models where two meters are used per hose for increased flow performance.

Dispenser Type	iMeter Modules	Meters per Module
Standard/Enhanced Capacity		
Single	1	1
Twin	1	2
Super High Capacity		
Single	1	2
Twin	2	2

- The iMeter is equipped with an intelligent pulser with two sets of sensors; one set for each meter. On the front of the pulser, there are two calibration doors; one for each meter in the iMeter module. The door closest to the front of the dispenser controls calibration of the front meter and the other door controls calibration of the rear meter (Standard/Enhanced Capacity singles do not have a rear meter).
- All iMeters are tested, calibrated, and sealed at the factory before a dispenser is shipped. As part of the start-up procedure, the accuracy should be verified, and if re-calibration is required, the calibration procedure should be followed. To thoroughly flush out all air and completely fill the system prior to verification and calibration, dispense product from the dispenser (and satellite if applicable) until a continuous and steady flow of product is observed at each nozzle.
- In applications involving the resale of fuel, for the initial use and after any adjustments to the calibration, the meter will need to be sealed by the appropriate Weights & Measures authority.

4.6.2 Accuracy Verification – Std./Enhanced Capacity & Super High Capacity

Step 1 Dispense product into a certified 5 gallon or 20 liter calibration container to wet the container and then empty it back into the tank, allowing it to drain for 10 seconds.

Step 2 Dispense product into the container until exactly 5 gallons (20 liters) are shown on the dispenser display.

Note: When temperature compensation is activated (Canada), the dispenser should be placed into Temp Comp Fueling Mode (ref. Appendix E), so that the accuracy can be verified using the gross (uncompensated) volume shown on the display in this mode.

Step 3 Compare the reading on the container's sight glass to the dispenser display. For the "Acceptance" test, the container volume should be within a total of +/- 1 cu. in. plus +/- 0.5 cu. in. for each gallon dispensed for a 5 or 10 gallon prover. For larger provers, the acceptance tolerance is $\pm 0.3\%$ (units rated up to 30 GPM).

Note: For U.S. weights & measures applications, acceptance tolerance of +/- 1 cu. in. plus +/- 0.5 cu. in. for each gallon dispensed (into a 5 or 10 gallon prover) and 0.3% into a larger prover, is only required for newly placed in service devices for 30 days. After 30 days, the maintenance tolerance is increased to +/- 1 cu. in. plus +/- 1 cu. in. for each gallon dispensed (into a 5 or 10 gallon prover) and 0.5% for larger provers. Consult Handbook 44 for full information.

- Step 4** If the values are out of range, follow the calibration procedure in Section 4.6.3.
- Step 5** Repeat the verification procedure for each hose.

4.6.3 Calibration Procedure – Std./Enhanced Capacity & Super High Capacity

- Step 1** Dispense product into the certified calibration container to wet the container and then empty it back into the tank, allowing it to drain for 10 seconds.
- Step 2** Identify the calibration door for the meter in need of calibration. Reference Figure 4-5 for the location of the calibration doors.

Note: An easy way to identify which meter corresponds to which hose is to start at the discharge outlet casting of the desired hose and trace the discharge line back to the meter. On super high capacity models, two meters feed one hose. At the discharge outlet casting, two discharge lines branch off from the casting. Trace each line back to its meter to determine the two meters tied to that hose. Each meter must be calibrated separately. When the calibration door of one meter is opened, it automatically closes the solenoid valve to the other meter so each meter can be calibrated independently.

Figure 4-5 iMeter Module

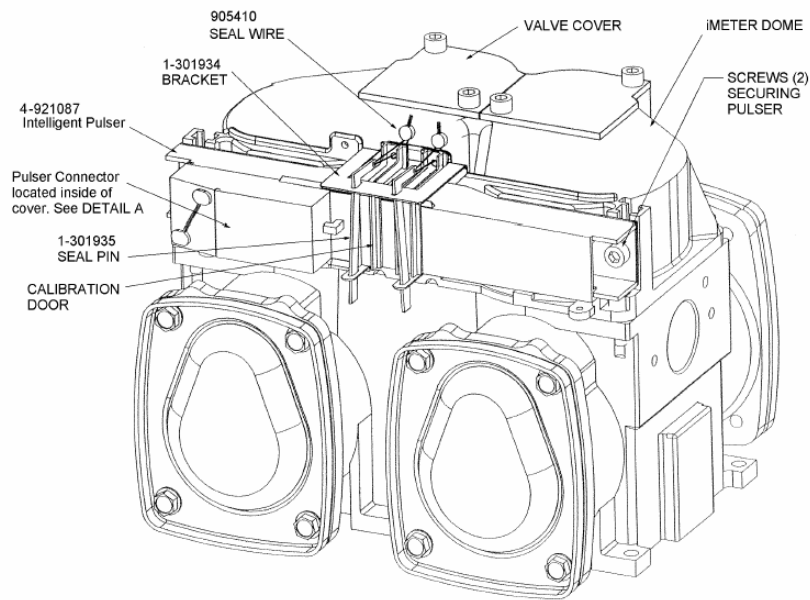

- Step 3** Proceed directly to step 4 if the dispenser is not a master dispenser connected to a satellite dispenser.

In master dispensers connected to a satellite dispenser, there will be a satellite outlet beneath the hose outlet being calibrated. On the pair of lines manifolded into this outlet, there will be one ball valve per pair. See Figure 4-6. When calibrating both meters, you must remove the sealing guard from the valve and close the valve to prevent product from circulating between the meters.

- Step 4** Remove the seal wire and pin to allow access to the calibration door.
- Step 5** Open the calibration door of the meter to be calibrated. (Only one door can be opened at a time during the calibration process.)

Step 6 Fill the calibration container (5 gallons or 20 liters) to exactly the “0” mark on the sight glass (read the bottom of the meniscus). Disregard any volumes shown on the dispenser display.

Note: With Super High Capacity models that will get verified with a larger test container (i.e. 50 or 100 gallons), it is important to try and duplicate the same filling characteristics with the smaller calibration container that will be used when filling the larger test container (as much as possible at full flow and avoid many nozzle snaps to reach the “0” mark). Otherwise, the dispenser may be outside the acceptance tolerance when verifying with the larger test container.

Step 7 Close the calibration door (this now redefines the calibration factor in the pulser) and return the nozzle to the nozzle boot.

Step 8 Empty the container back into the tank and let it drain for 10 seconds.

Step 9 For non-super high capacity models, proceed directly to step 11.

Super high capacity models have two meters tied to one hose. Repeat steps 4 thru 8 for the second meter. (Note: super high capacity models can be identified by a “2” in the third digit following the “G” in the model number; e.g., 3/G2221D.)

Step 10 For master dispensers connected to a satellite, after both meters have been calibrated, re-open the ball valve on the satellite line.

Step 11 Verify the accuracy by following the verification procedure in Section 4.6.2.

Step 12 Seal the calibration door (both doors if a super high capacity model) and seal the ball valve if applicable.

Step 13 Repeat the calibration procedure for each hose.

Figure 4-6 Super High Capacity Master with Satellites

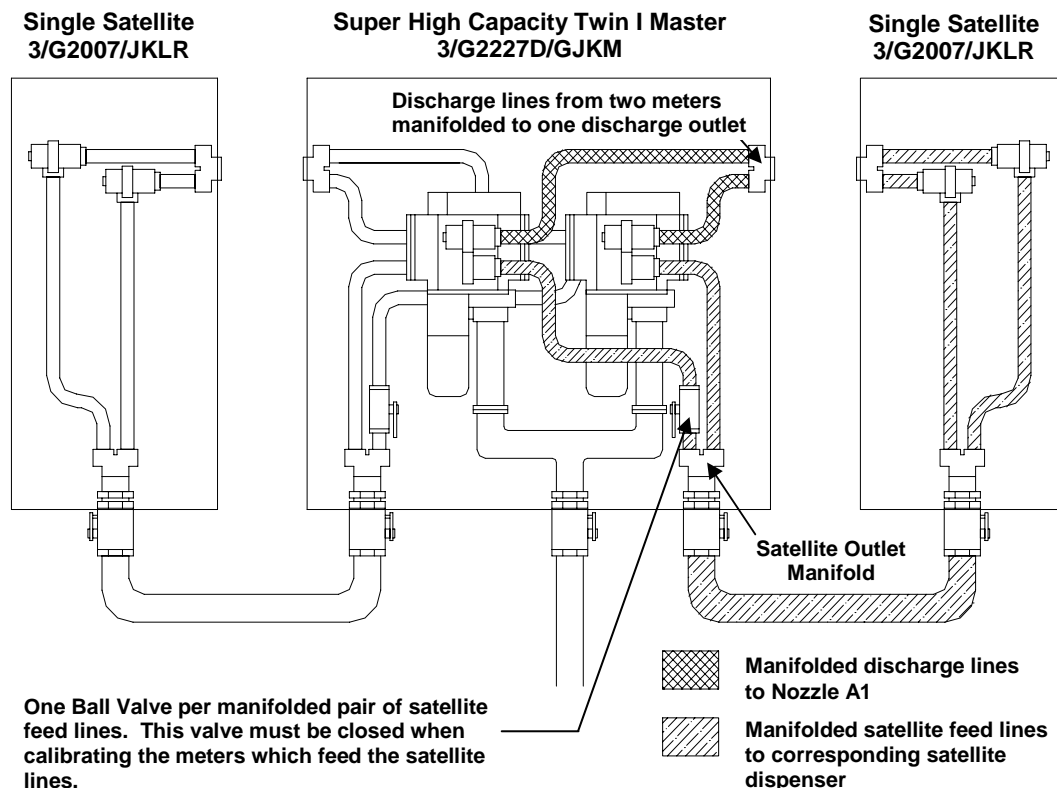

4.7 Meter Check (Calibration) – Ultra High Capacity Models

4.7.1 General

- Ultra High Capacity models use the Liquid Controls (LC) M-5 meter with a Wayne optical pulser to measure the fuel dispensed. One meter is used per hose
- The LC meter is used in conjunction with a Pulse Processing Module (PPM) that is located in the head of the dispenser. The PPM has a switch for each meter that is used to calibrate the meter. Switch “Side A – M1” is used to calibrate the meter on Side A while switch “Side B – M1” is used to calibrate the meter for Side B. If the dispenser has two hoses on the same side, Switch “Side A – M1” is used for Hose 1 and “Side B – M1” is used for Hose 2.
- All LC meters are tested, calibrated, and sealed at the factory before a dispenser is shipped. As part of the start-up procedure, the accuracy should be verified, and if re-calibration is required, the calibration procedure should be followed. To thoroughly flush out all air and completely fill the system prior to verification and calibration, dispense product from the dispenser (and satellite if applicable) until a continuous and steady flow of product is observed at each nozzle.
- In applications involving the resale of fuel, for the initial use and after any adjustments to the calibration, the meter will need to be sealed by the appropriate Weights & Measures authority.

4.7.2 Accuracy Verification – Ultra High Capacity

Note: A calibration container that handles at least 50 gallons (or 190 liters) is recommended for verifying, and calibrating if necessary, this high capacity dispenser. After replacing the Pulse Processing Module, the dispenser must be calibrated prior to running an accuracy verification test.

Step 1 Dispense product into a certified calibration container to wet the container and then empty it back into the tank, allowing it to drain for 10 seconds.

Step 2 Dispense product into the container until exactly the quantity of the container is shown on the dispenser display.

Note: When temperature compensation is activated (Canada), the dispenser should be placed into Temp Comp Fueling Mode (reference Appendix E), so that the accuracy can be verified using the gross (uncompensated) volume shown on the display in this mode.

Step 3 Compare the reading on the container’s sight glass to the dispenser display. For the “Acceptance” test, the container volume should be within a total of +/- 1 cu. in. plus +/- 0.5 cu. in. for each gallon dispensed for a 5 or 10 gallon prover. For larger provers, the acceptance tolerance is $\pm 0.2\%$ (units rated over 30 GPM).

Note: For U.S. weights & measures applications, acceptance tolerance of +/- 1 cu. in. plus +/- 0.5 cu. in. for each gallon dispensed (into a 5 or 10 gallon prover) and 0.2% into a larger prover, is only required for newly placed in service devices for 30 days. After 30 days, the maintenance tolerance is increased to +/- 1 cu. in. plus +/- 1 cu. in. for each gallon dispensed (into a 5 or 10 gallon prover) and 0.3% for larger provers. Consult Handbook 44 for full information.

Step 4 If the values are out of range, follow the calibration procedure in Section 4.7.3.

Step 5 Repeat the verification procedure for each hose.

4.7.3 Calibration Procedure – Ultra High Capacity

Step 1 Verify that the dispenser calibration volume is set to match the test container that will be used to calibrate the dispenser. This can be checked (and if needed changed) using the F19.26 (Gallons) or F19.16 (Liters) function in the dispenser software configuration. The entry must be in whole Gallons or whole Liters.

Step 2 Dispense product into the certified calibration container to wet the container and then empty it back into the tank, allowing it to drain for 10 seconds.

Step 3 Identify the calibration switch for the meter in need of calibration. The Pulse Processing Module (PPM) is located in the electronics area of the dispenser. As you face the iGEM CPU, the PPM is mounted on a bracket on the interior of the left side column. The switches are located behind a bracket used to seal the switches. Reference Figure 4-7 for the location of the calibration switches.

Note: To identify the hose designation, when viewing the dispenser from the side of the iGEM CPU, the Hose A discharge outlet is always on the left side of the dispenser and the Hose B discharge outlet is always on the right side.

Figure 4-7 Pulse Processing Module

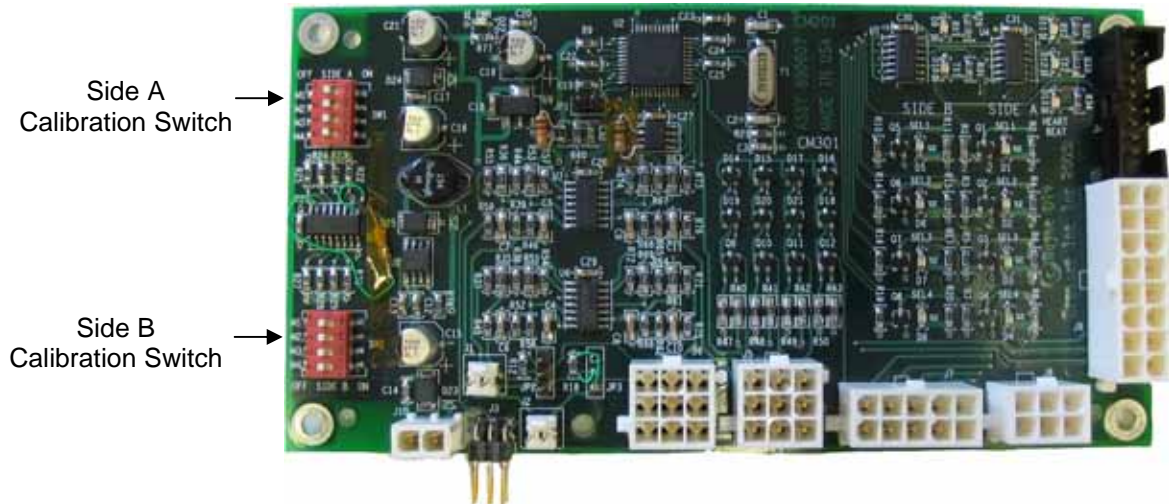

Step 4 Remove the seal wire and screw to allow access to the calibration switch.

Step 5 Set the calibration switch of the meter to be calibrated to the “on” position. “CAL” will display on the dispenser Unit Price display indicating the dispenser is in calibration mode.

Step 6 Fill the calibration container to exactly the “0” mark on the sight glass (read the bottom of the meniscus). Disregard any volumes shown on the dispenser display.

Step 7 Return the nozzle to the nozzle boot and set the calibration switch to the “off” position (this now redefines the calibration factor in the PPM). If the calibration is accepted by the dispenser, ‘rECd’ will show in the Unit Price display for 5 seconds. If the calibration is rejected, a “C-Er” message will appear in the display for 5 seconds, and the calibration procedure will need to be repeated.

Step 8 Empty the container back into the tank and let it drain for 10 seconds.

Step 9 Verify the accuracy by following the verification procedure in Section 4.7.2.

Step 10 If this is a twin dispenser, repeat the calibration procedure for the other hose.

Step 11 Replace the calibration switch cover and seal the calibration cover.

4.8 Pulley Alignment (Suction Pump Models)



WARNING

Make sure power to the dispenser is turned off before checking or realigning the pulleys. Failure to do so may result in a hazardous condition that can result in serious injury.

- Step 1** Check that the suction pump pulley and the motor pulley are in straight alignment. Lay a straight edge ruler against both outer pulley sheaves, where the pump pulley is the reference surface. The motor pulley must be within 1/8" (32mm) of straight alignment with the pump pulley.
- Step 2** If the motor pulley requires adjustment, loosen the set screw on the inside of the pulley which holds the key against the motor shaft. Align the pulley and retighten the set screw.

4.9 Belt Adjustment (Suction Pump Models)



WARNING

Make sure power to the dispenser is turned off before checking or adjusting the belt tension. Failure to do so may result in a hazardous condition that can result in serious injury.

The Wayne Century Series utilizes an adjustable v-link belt. If the belt appears too loose or too tight, the belt can be disassembled to check the measurement. Links may be removed or added to change the tension. The only adjustment to change the tension on the belt should be adding or removing a link. Follow the procedures below if the belt needs adjustment.

Step 1 Remove the belt from the pulleys.

Step 2 Disassemble the link belt.

- Turn the belt inside out (tabs facing out).
- Take a section of the belt and with one hand squeeze the two sides together as tight as possible.
- With the other hand, twist one tab 90° so it is parallel with the slot. See Figure 4-7.
- With the same hand, pull the end of the link over the tab.
- Rotate the side of the belt with the tab 90° and pull the tab through the two link slots.



Figure 4-8 Disassembling the Link Belt

Step 2 Measure the belt for the correct tightness.

- Wrap the two ends of the belt around the motor and suction pump pulleys with the tabs facing into the pulleys.
- Pull the ends tight together. For the correct tension, when the belt is pulled tight, the ends of the belt should just touch.
- Remove or add links to achieve the required spacing.



Figure 4-9 Sizing the Link Belt

Step 3 Assemble the link belt

- With the tabs facing out, hold the ends of the belt.
- Slide the end tab through the two link slots at once and twist the belt back in straight alignment.

- Using the index finger on your hand holding the tab end of the belt, turn the second tab 90° (hint: twisting the tab end of the belt in toward your body at the same time will help bring the tab parallel with the slot). With the index finger of your other hand, push the tab slot down over the tab. Squeeze the belt sides together to force the tab all the way through the slot.



Figure 4-10 Re-Assembling the Link Belt

- Make sure the tab returns to its position across the belt. Turn the belt so the tabs are on the inside.

Step 4 Install the belt on the pulleys

- Make sure the tabs are facing the inside before installing.
- Determine the direction of the drive rotation (CCW facing the pulleys) and install the belt with the printed arrows on the outside of the belt pointing in the direction of the rotation.
- Fit the belt in the groove of the motor pulley and roll the belt into the groove of the suction pump pulley by turning the drive slowly. The belt may seem very tight. **This is okay; do not jog motor.**
- Check to make sure that all tabs are still in their correct position and are not twisted out of alignment.

4.10 Compact Pumping Unit Adjustment (Suction Pump Models)

The bypass valve pressure in the compact pumping unit should be checked and adjusted if necessary. If there is not enough pressure, the pump will deliver product slowly. If the pressure is too high, delivery of the product will not increase, but increased noise and wear will result, and an unnecessary load will be placed on the motor.

- Step 1** Before checking the bypass pressure, follow the steps in Section 6.2 for cleaning the pump strainer.
- Step 2** To check the bypass pressure, remove the priming plug (see Figure 4-11) and install a pressure gauge in the priming port.
- Step 3** Turn the pump on, so that the motor and pumping unit are running, but leave the nozzle closed. Verify that the pressure is in the 29 – 30 psi range (factory setting).
- NOTE:** The bypass pressure may be raised to increase the flow, or lowered to decrease the flow. When changing the bypass pressure, always verify that the amperage draw does not exceed the amp rating of the motor.
- Step 4** If the bypass pressure needs adjustment, remove the acorn nut (cap) that covers the adjustment screw and lock nut. Loosen the lock nut and turn the adjustment screw clockwise to increase the pressure and counter-clockwise to lower the pressure. Once the correct pressure is reached, tighten down the lock nut and replace the acorn nut.
- Step 5** With the nozzle open and dispensing fuel, verify that the amps are less than the motor amp rating (reference the Component Electrical Rating section in Appendix B). If the amps exceed the motor rating, the bypass must be lowered until the amps are below the rating.

Figure 4-11 Compact Pumping Unit

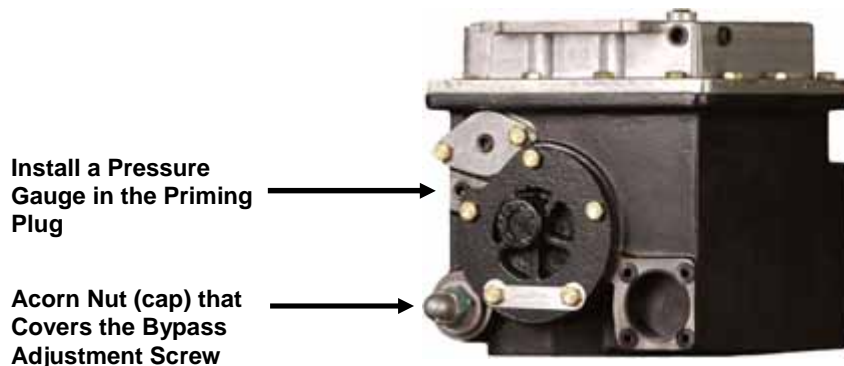

4.11 Fluorescent Lights

- Turn on the light circuit breaker (if on a separate circuit), and ensure that the fluorescent lights operate correctly.
- If the bulbs fail to illuminate, follow the instructions on bulb replacement in Section 6.6.

4.12 Voltage Test

- While the dispenser is turned off, verify the incoming voltage to the dispenser is within \pm 10% of the rated voltage. If the voltage is not within the acceptable range, take the appropriate corrective measures before using the dispenser.
- For suction pump models, turn the dispenser on and record the voltage readings while the nozzle is open (dispensing) and then closed (bypass). Any voltage drops in excess of 10% need to be corrected.

4.13 Complete Installation

- Re-check the dispenser and all piping and hose connections to make sure all connections are tight and there are not any signs of leaks.
- Make sure you have completed all of the manufacturers' test procedures for all equipment, piping, and accessories utilized in the fuel dispensing system.
- After all tests have been completed successfully, and a proper installation and operation are verified, the tank and piping may be covered and the conduit openings should be appropriately sealed.
- The installer should make sure the following items are left with the fuel site owner:
 - All documentation and manuals
 - Infrared Remote Control
 - Local Authorization Jumper if connected to a fuel control system

5 OPERATION

5.1 Safety Items You Should Know

- Know how to turn OFF power to the dispenser and submersible pumps in an emergency.
- Use the dispenser for appropriate applications. Use only low viscosity fuels – diesel, including biodiesel blends up to 20%; kerosene; gasoline, including standard oxygenated blends. Do not use the pump for pumping water or water-based liquids.
- Make sure the dispenser is equipped with the proper accessories for the application and product dispensed – for example, the proper filters and separators to ensure product purity when refueling aircraft.
- Inspect regularly, all external fuel carrying components such as, hoses, nozzles, breakaways, etc., for damage or leaks.
- Inspect regularly, the pump housing parts for damage or leaks.
- Have all leaks or defects repaired immediately.
- For remote dispensers, test the emergency (shear) valve, by opening and closing several times, at least once per year.
- Care should be taken to prevent fuel spillage. If spillage occurs, clean-up immediately.
- Use of automatic safety nozzles prevents overfilling fuel tanks and avoids spilling fuel.
- Avoid tipping the nozzle downward spilling excess fuel.
- Sufficient lighting must be provided to allow safe use of the pump.
- A clearly visible and identifiable Site Emergency Stop Switch must be provided at the site to shut OFF power to all of the site's dispensers and submersible pumps in case of an emergency.
- Stow hoses to prevent tripping.
- Avoid moving parts such as the v-belts and pulleys on suction pump models. Do not operate the pump with the doors open.
- Beware that internal hose retractor mechanisms are spring-loaded and can cause a possible injury.
- Know the Hazardous Zone area around the dispenser.
- Do not operate the dispenser in the presence of any source of ignition including lighted cigarettes, electrical equipment, and running/hot engines.
- Always keep an operating nozzle attended and do not re-enter the vehicle after beginning the fueling sequence. Static buildup can be created from sliding in and out of the vehicle seat. Static discharge by subsequently touching an operating nozzle can create a hazardous situation.
- Portable tanks (containers) of 12 gallons (45 liters) or less shall not be filled while they are in or on a motor vehicle. See Warning information about this subject on the following pages.
- Wear safety goggles and protective clothes when dispensing any liquid that may be potentially harmful or hazardous. Change saturated clothing and wash skin promptly with soap and water.

5.1.1 Portable Tanks and Containers

Portable containers of 12 gallons (45 liters) or less shall not be filled while they are in or on a motor vehicle. Filling portable containers, especially when they are sitting on a non-conductive surface such as a floor mat or a plastic bedliner in the back of a pick-up truck, can present a possible safety hazard and should be avoided as so stated in the following WARNING:



WARNING

FIRE HAZARD!

The flow of gasoline through the dispenser nozzle can produce static electricity, which can cause a fire if gasoline is pumped into an ungrounded gasoline container. To avoid static buildup and the possible resulting serious injury:

- Place approved container on the ground. Do not fill the container in the vehicle or truck bed.
- Keep the nozzle in contact with the can or container while filling. Do not use an automatic pump handle (latch-open) device.

5.1.2 Health Note

Be advised that petroleum fuel and fuel vapors can damage your health.

5.2 Dispenser Operation

To Dispense Fuel:

- Step 1** If the dispenser is connected to a fuel control system, first authorize the dispenser at the control system. Otherwise, proceed directly to step 2.
- Step 2** Remove the nozzle from the nozzle holder.
- Step 3** Lift the on/off nozzle hook upwards to the on position.
- Step 4** The dispenser displays will automatically reset to all zeros. On suction pump models, the motor will then be turned on. In remote dispensers models, the submersible pump will be turned on, and then the solenoid valve in the dispenser will be opened.
- Step 5** Insert the nozzle into the vehicle's fill tank and squeeze the nozzle handle to dispense fuel.
- Step 6** After fueling is complete, lower the on/off nozzle hook lever to the down "off" position to shut off the dispenser, and re-insert the nozzle into the holder.

NOTE: If a control system is not being used, the nozzle may be locked into the nozzle holder to prevent unauthorized usage.

5.3 Electromechanical Totalizers

- An externally visible electromechanical non-resettable totalizer for each hose is provided as standard on all models, except for Standard/Enhanced Capacity Twin I models where the totalizers are per product. Standard/Enhanced Capacity twin I models must be equipped with the Electromechanical Totalizer per Hose option (/K model suffix) for per hose electromechanical totals.
- The totalizer(s) records up to seven whole digits (9,999,999).
- To view the electromechanical totalizers, look towards the top of the discharge side(s) of the dispenser.
- Electronic totals are also available. See Section 5.4.4, Viewing Electronic Totalizers.

5.4 Dispenser Statistics & Diagnostics

5.4.1 General

- The Century Series provides a variety of statistical and diagnostic information. This section covers the electronic totalizers. For a complete list of all available information, reference Appendix C.10.
- The statistics and diagnostics can be accessed without opening the dispenser. The interface is handled through an infrared remote control (IRC) that is shipped with the dispenser. To use the IRC, point it at the dispenser displays from within a distance of a couple of feet and press the desired keys. The nozzle hook on/off lever must be in the “off” position to access the statistics and diagnostics.
- Responses to the IRC commands are shown on the dispenser displays. Statistic function and subfunction numbers are shown in the Unit Price display and their corresponding values are shown in the Gallons/Liters display. Reference Figure 5-1.

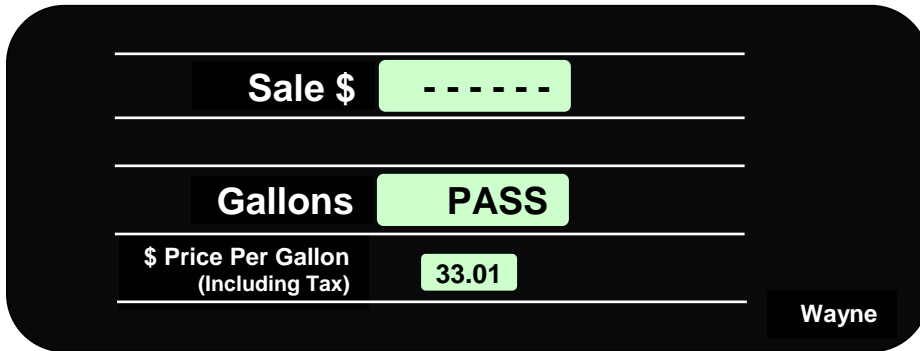

Figure 5-1 In this example, the unit price display shows subfunction 33.01 (change service engineer password) with “PASS” shown in the Gallons display since the actual password is not shown for security



Figure 5-2 Infrared Remote Control (IRC)

5.4.2 Password Protection

- Access to dispenser statistic, diagnostic, and configuration information is password-protected. Three levels of passwords are provided to control different levels of access. This allows you to provide a site operator password to an employee to read electronic totals without concern that configuration settings could be accidentally changed.

Password Type	Access Level	IRC Sign-on Command
Service Engineer	Read and write access for all dispenser configuration settings, statistics, & diagnostics	ENTER
Site Manager	Read and write access to limited configuration settings and all statistics & diagnostics	1
Site Operator	Read only access to statistics (e.g. totalizers)	2

5.4.3 Viewing the Electronic Totalizers

- The Century Series provides one resettable total and one non-resettable totalizer for each hose. These totalizers record up to 999,999 units (gallons or liters).
- In order to read the totalizers, you first need to understand how the dispenser sides and nozzles are identified in the software.
 - **Single Hose Models:** Single hose models only have a Side A, Nozzle #1 (A1).
 - **Twin Hose Models:** Two-hose models have a Side A, Nozzle #1 (A1) and a Side B, Nozzle #1 (B1). Using the main junction box to determine the physical orientation of the dispenser, reference Figures 5-3 and 5-4 to find out the nozzle assignments. (Note on UHC dispensers, the j-box is centered. Dispensers with the pulse output interface option have a second junction box on the opposite side for the pulse output interface wire terminations. The main AC j-box has a 3/4" conduit and the pulse output j-box has a 1/2" conduit.)

Figure 5-3 Twin Dispensers w/ Island-Oriented Nozzle Boots

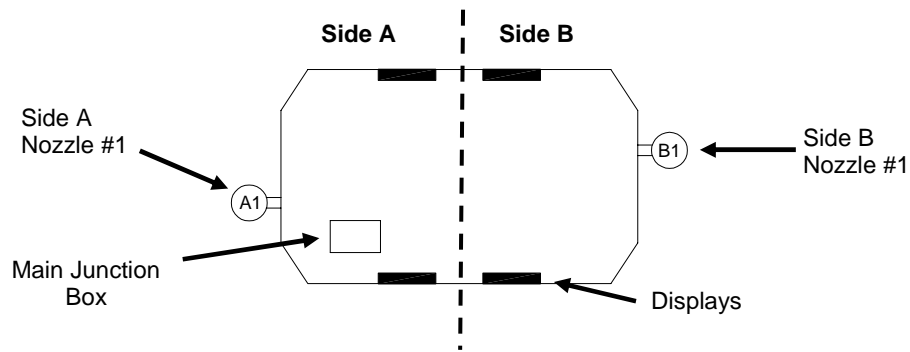

Figure 5-4 Twin Dispensers w/ Lane-Oriented Nozzle Boots

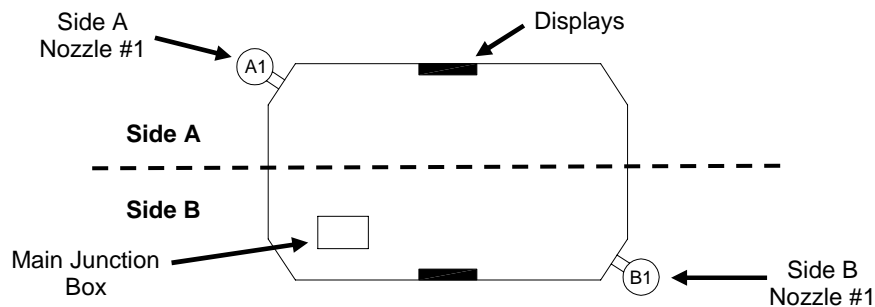
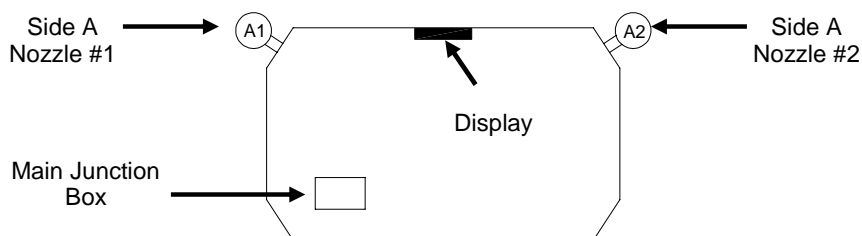

Figure 5-5 Single-Sided Twin Dispensers w/ Lane-Oriented Nozzle Boots



5.4.3.1 Non-Resettable Electronic Totalizers (Statistics S11 & S12)

- The following terminology is used in the documentation to help clarify the statistical functions:

Totalizer – A non-resettable total

Total – A resettable total

Enter Statistics				
Step	IRC Command	Sale \$ Display	Volume Display	Unit Price Display
1 Service engineer sign on	Press <ENTER>	PASS 1	[blank]	[blank]
2 Enter default service engineer password	Type Password & Press <ENTER>	PASS 2	[blank]	[blank]
3 Re-enter default service engineer password	Type Password & Press <ENTER>	[software version]	[software date]	F --
4 Go to statistics entry point	Press <DOWN>	[side A transaction count]	[side B transaction count]	S --
View Non-Resettable Totalizer – Side A Nozzle #1 (A1)				
5 Go to Side A non-resettable totalizer function	Type <11> & Press <ENTER>	-----	[blank]	S 11
6 Go to nozzle #A1 sub-function	Press <ENTER> again	[blank]	[totalizer A1 value]	11.11
7 Return to function level	Press <ENTER> again	-----	[blank]	S 11
View Non-Resettable Totalizer – Side B Nozzle #1 (B1) (if you only have one nozzle, skip to Step #11)				
8 Go to Side B non-resettable totalizer function	Type <12> & Press <ENTER> or if you are at S 11, you can also just press <NEXT>	-----	[blank]	S 12
9 Go to nozzle #B1 sub-function	Press <ENTER> again	[blank]	[totalizer B1 value]	12.11
10 Return to function level	Press <ENTER> again	-----	[blank]	S 12
Exit Statistics				
11 Return to statistics entry point	Press <CLEAR>	[side A transaction count]	[side B transaction count]	S --
12 Exit statistics	Press <ENTER> 3 times	[last transaction]	[last transaction]	[Price]

5.4.3.2 Resettable Electronic Totals (Statistics S01 & S02)

Enter Statistics				
Step	IRC Command	Sale \$ Display	Volume Display	Unit Price Display
1 Enter sign on	Press either <ENTER>, <1>, or <2> depending upon access level Note: If you only have operator access (2), you cannot reset totals.	PASS 1	[blank]	[blank]
2 Enter your password	Type Password & Press <ENTER>	PASS 2	[blank]	[blank]
3 Re-enter your password	Type Password & Press <ENTER>	[software version]	[software date]	F --
4 Go to statistics entry point	Press <DOWN>	[side A transaction count]	[side B transaction count]	S --
View Resettable Total -Side A Nozzle #1 (A1)				
5 Go to Side A resettable totals function	Type <1> & Press <ENTER>	-----	[blank]	S 01
6 Go to nozzle #A1 sub-function	Press <ENTER> again	[blank]	[totalizer A1 value]	1.11
Reset Total - Side A Nozzle #1 (A1) - to Zero (if you do not want to reset total, skip to Step #10)				
7 Clear total	Press <#>	CLEAR	totALS	1.11
8 Confirm clear	Press <ENTER>	PASS	[blank]	1.11
9 Enter reset password	Type <42> & Press <ENTER>	-----	[blank]	S 01
View Resettable Total - Side B Nozzle #1 (B1) (if you only have one nozzle, skip to Step #15)				
10 Go to Side B resettable totals function	Press <NEXT>	-----	[blank]	S 02
11 Go to nozzle #B1 sub-function	Press <ENTER>	[blank]	[totalizer B1 value]	2.11
Reset Total - Side B Nozzle #1 (B1) - to Zero (if you do not want to reset total ,skip to Step #15)				
12 Clear total	Press <#>	CLEAR	totALS	2.11
13 Confirm clear	Press <ENTER>	PASS	[blank]	2.11
14 Enter reset password	Type <42> & Press <ENTER>	-----	[blank]	S 02
Exit Statistics				
15 Return to statistics entry point	Press <CLEAR> Note: if you are not resetting the totals, press <ENTER> 3 times to exit statistics	Side A transaction count	Side B transaction count	S --
16 Go to function level	Press <UP>	Software Version	Software Date	F --
17 Go to exit function	Type <0> and Press <ENTER>	-----	[blank]	F 00
18 Go to exit sub-function	Press <ENTER> again	-----	1	0.00
19 Clear display	Press"#"	[blank]	1	0.00
20 Exit and save changes	Type <3> & then press <ENTER>	-----	3	0.00
21 Exit configuration	Press <ENTER> again	CHAnGE	StorEd	Price

6 MAINTENANCE

6.1 Preventive Maintenance

The safety precautions described in Section 2.2 apply to the following preventive maintenance procedures. A correctly installed dispenser, given proper preventive maintenance attention, will seldom require emergency service. Perform the following checks on a regular basis:

- Check the dispenser for internal and external leaks regularly. Check nozzles, swivels, hoses, filters, and joints for leaks and wear. Have all defects repaired immediately.
- Do not abuse the hose by trying to stretch it to reach a vehicle. This will cause early failure at the couplings.
- Keep the dispenser clean at all times. See Section 6.4 for cleaning/polishing instructions and warnings.
- Test the tank for water regularly. Water in petroleum is not only a source of engine trouble, but will also cause damage to the pump.
- Periodically check and lubricate all key lock cylinders and locking mechanisms.

6.2 Strainer/Filter – Standard/Enhanced Capacity & Super High Capacity Models **Note: Reference Section 6.3 for Ultra High Capacity models.**

A dirty strainer screen and/or filter will slow down the product delivery. With new tank and piping installations, it may be necessary to replace the filter and clean the strainer screen two or three times during the first few days of operation to remove installation debris and pipe sealant. After this, filter replacement and strainer cleaning should be performed periodically.



WARNING

Before removing the filter or strainer, always turn off the power to the dispenser, and if applicable, turn off the power to the submersible pump and close the emergency shutoff valve underneath the dispenser. Failure to do so may result in a hazardous condition that can result in serious injury. Make sure safety goggles are worn. Loosen the strainer cap or spin-on filter slightly and allow the product to drain into a plastic container until pressure is relieved. Return the product to the appropriate tank.

- The filter is removed by unscrewing it (the same way an oil filter is removed from a car engine). Place a container under the filter to catch the product and sediment. To install the new filter: apply a film of oil to the gasket, hand turn until gasket contacts base, then tighten 3/4 turn (follow any directions supplied with filter). Open the emergency shutoff valve (if applicable), turn the electrical power ON and check for leaks.



WARNING

Remote dispensers are shipped with a 30-micron particulate filter. This filter does not provide water absorption. The installer and user should make sure the filter meets the requirements of the application, satisfies local/state/federal codes, and replace the filter with an appropriate filter as necessary. Some applications, such as aircraft refueling, require special filtration equipment in order to ensure product purity. Replacement filters must be UL-recognized.

- Remove the strainer for cleaning by removing the bolts from the strainer cap. Place a container under the cap to catch the product and sediment. Pull out the strainer. Wash the screen in gasoline and dislodge lint and other foreign particles with compressed air. Install the clean strainer and replace the strainer cap. Open any emergency shutoff valves and turn the electrical power ON and check for leaks.

6.3 Filters – Ultra High Capacity Models

NOTE: Ultra high capacity models have two high capacity filters per hose prior to the meter in place of an inlet strainer. If the filters are removed for any reason (e.g. external filters are desired), they must be replaced with disposable 100-mesh strainer canisters (p/n 890255-002) in order to protect the meter.

Dirty filters will slow down the delivery of product. With new tank and piping installations, it may be necessary to replace the filters two or three times during the first few days of operation to remove installation debris and pipe sealant. After this, filter replacement should be performed periodically. If strainer canisters are used, a drop in flow may indicate a need to replace the disposable strainer.



WARNING

Before removing the filters or strainer canisters, always turn off the power to the dispenser, and if applicable, turn off the power to the submersible pump and close the emergency shutoff valve underneath the dispenser. Failure to do so may result in a hazardous condition that can result in serious injury. Make sure safety goggles are worn. Loosen the filter or strainer canister slightly and allow the product to drain into a plastic container until pressure is relieved. Return the product to the appropriate tank.

- The filters or strainer canisters are removed by unscrewing it (the same way an oil filter is removed from a car engine). Place a container under the filter to catch the product and sediment. To install the new filters or strainer canisters: apply a film of oil to the gasket, hand turn until gasket contacts base, then tighten 3/4 turn (follow any directions supplied with filter). Open the emergency shutoff valve (if applicable), turn the electrical power ON and check for leaks.



WARNING

Remote dispensers are shipped with 30-micron particulate filters (unless the dispenser is supplied with the optional strainer canister). These filters do not provide water absorption. The installer and user should make sure the filters meet the requirements of the application, satisfy local/state/federal codes, and replace the filters with appropriate filters as necessary. If strainer canisters are used, or for special applications even when the internal filters are supplied, external filters, used on the discharge, may be required for the application. Some applications, such as aircraft refueling, require special filtration equipment in order to ensure product purity. Replacement filters must be UL-recognized.

6.4 Cleaning and Corrosion Prevention Instructions

To properly care for your dispenser:

Step 1 Wash the dispenser frequently with a non-abrasive cloth and warm water mixed with a mild household cleaner such as dishwashing liquid. The dispenser should then be wiped down with a clean damp cloth.

Note: Do not direct pressurized water, even a garden hose, at the dispenser.

Note: Do not use all-purpose cleaners on any part of the dispenser. They may scratch clear plastic, as well as break down the corrosion resistance of painted and stainless steel surfaces.

Note: Do not use gasoline or other petroleum-based products to clean the dispenser.

- Step 2** Exposure to contaminants can cause discoloration of any stainless steel panels. If the discoloration persists after Step 1, the use of an abrasive powder cleaner can be used to restore the original shine. Two cleaners in particular are very effective and practical to use: **Zud Heavy Duty Cleaner** and **Bar Keepers Friend**. They can both be found in most hardware or grocery stores. Follow the manufacturers' instructions for use and always rub in the direction of the brush finish to prevent scratching the stainless steel.
- Step 3** Periodic waxing (three times per year) of the dispenser surfaces is essential to maintain the original finish and inhibit corrosion. Painted surfaces should be waxed with an automotive wax or polish. Stainless steel surfaces should be polished with a non-abrasive silicone wax.

6.5 Meter Maintenance Issue

- For Weights & Measures applications, it is recommended that Wayne Fuel Meters be periodically checked for acceptable accuracy based on NCWM Handbook 44 under the General Code, G-UR.4 Maintenance Requirements and Liquid Measuring Device Code, Section 3.30.
- If adjustment needs to be made, follow the appropriate prescribed procedure in either Section 4.6, Meter Check (Calibration) – Standard/Enhanced Capacity & Super High Capacity or Section 4.7, Meter Check (Calibration) – Ultra High Capacity Models. All adjustments shall be made in accordance with G_UR.4 Maintenance Requirements of Handbook 44.

6.6 Fluorescent Light Bulb Replacement

- Step 1** While supporting the weight of the display panel with your free hand, unscrew the two screws on the front bottom edge of the panel. Lower the panel and temporarily hang it by placing the slots on the top edge of the panel through the tabs in the base of the electronic compartment.
- Step 2** Pull the u-shaped fluorescent light out of its fixture and replace with an equivalent bulb.
- Step 3** Lift the display panel back up under the lip of the top cover and secure in place with the two screws.

6.7 How to Get Service on Your Pump

- Trouble with the operation of the dispenser should be referred to your local Wayne authorized service personnel or call the Wayne Help Desk at **1-800-289-2963**.



CAUTION

Any modification, repair, or service to the dispenser, not in accordance with the original design, may invalidate compliance with the equipment certifications such as UL, CSA, etc. Consult manufacturer as necessary.

APPENDIX A



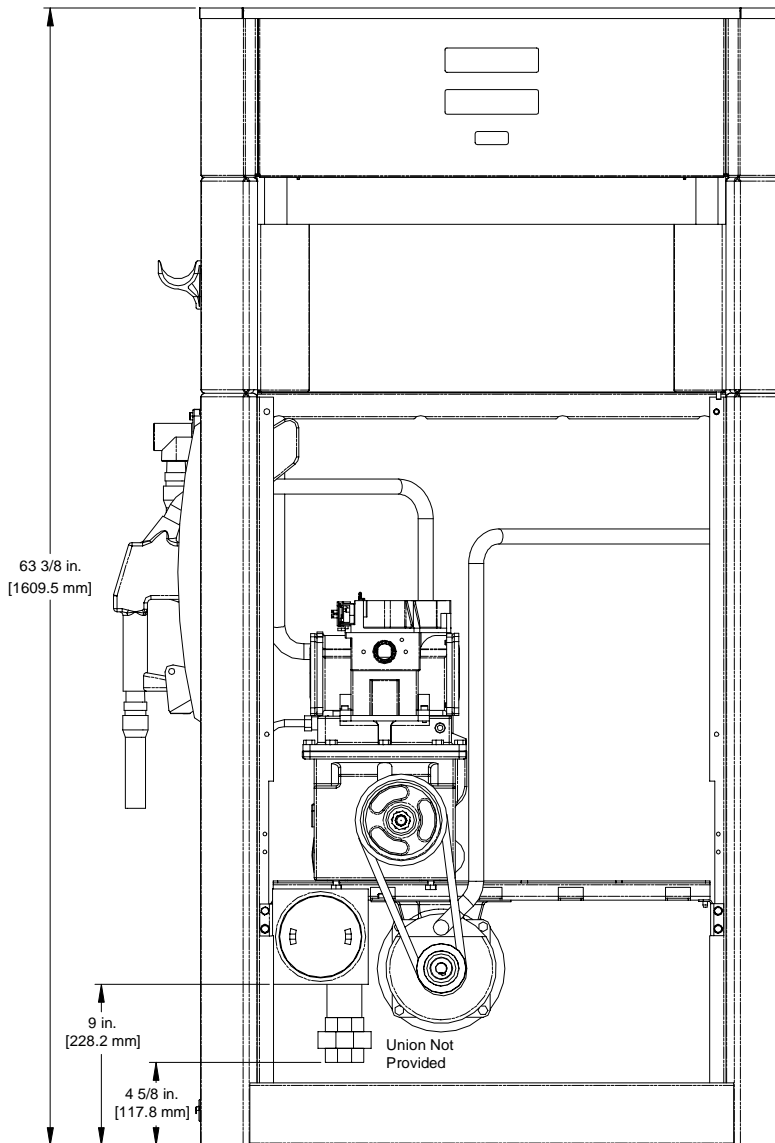

DIMENSIONS & BASE LAYOUTS

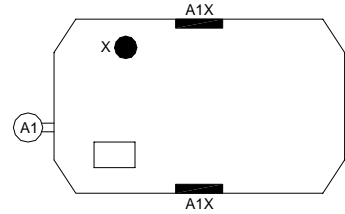

Base Orientation

3/G2201P/JK
Single Suction Pump
Island-Oriented



-  Display
-  Nozzle Boot
-  Dispenser Inlet
-  Main J-Box

The interior dimensions of the dispenser provide a maximum rectangular area of 16" x 29" for containment sumps (shown by dashed corners in the base layout).

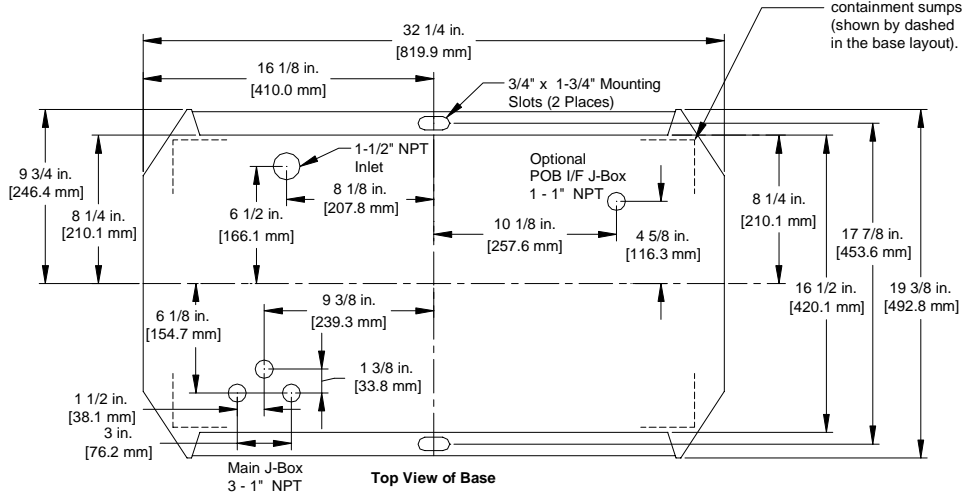

Models: 3/G2202P/JK Twin I Suction Pump – Island
3/G2207P/JK Twin I Suction Pump – Lane

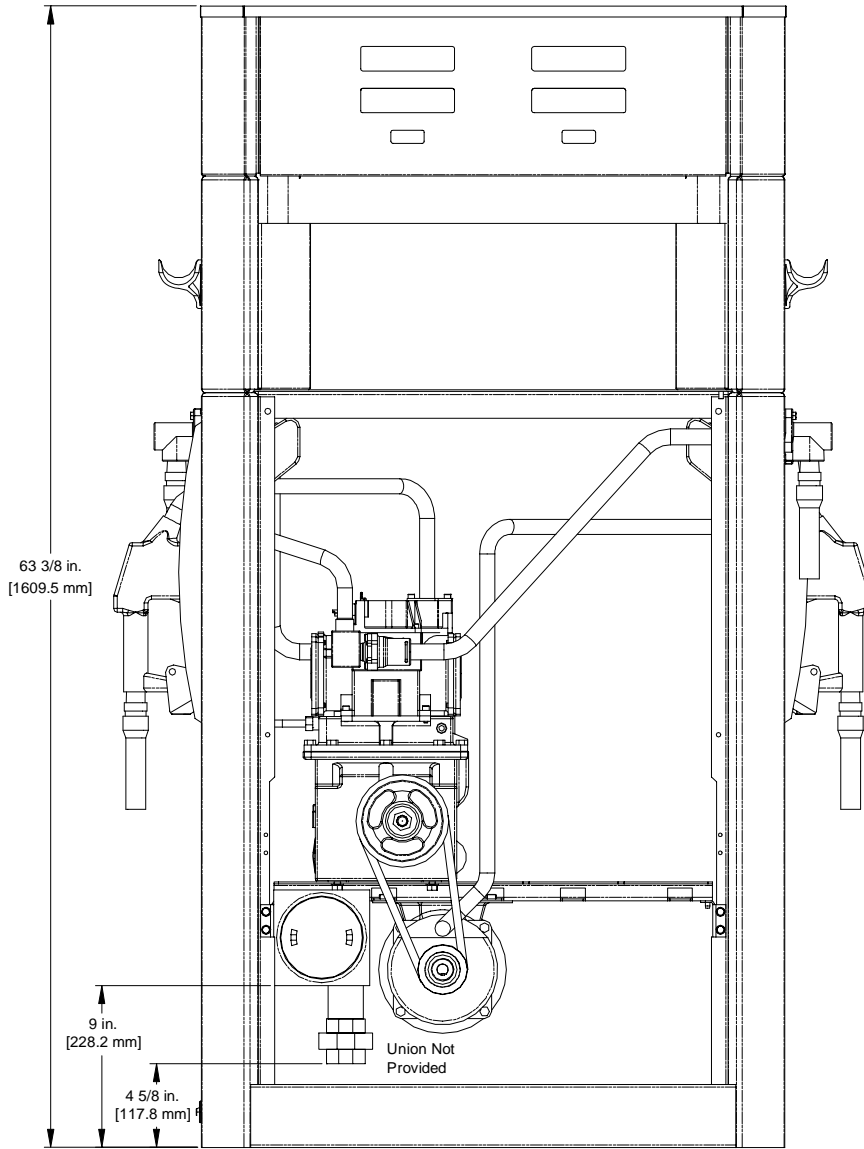

3/G2202P/2JK Shown

Base Orientation

3/G2202P/JK
Twin I Suction Pump
Island-Oriented

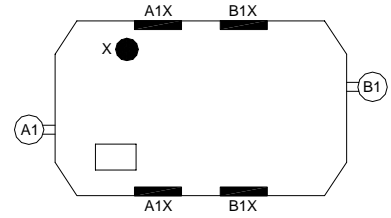

3/G2207P/JK
Twin I Suction Pump
Lane-Oriented

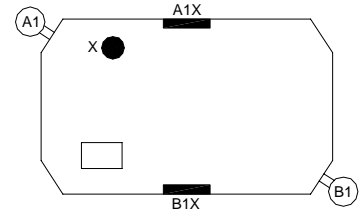

- Display
- Nozzle Boot
- Dispenser Inlet
- Main J-Box

The interior dimensions of the dispenser provide a maximum rectangular area of 16" x 29" for containment sumps (shown by dashed corners in the base layout).

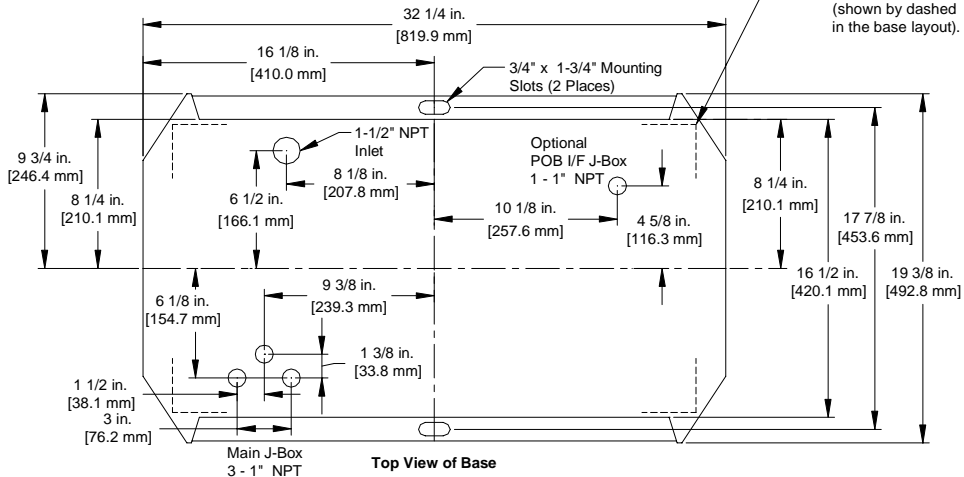

Top View of Base

Models: 3/G2203P/JK

Twin II Suction Pump – Island

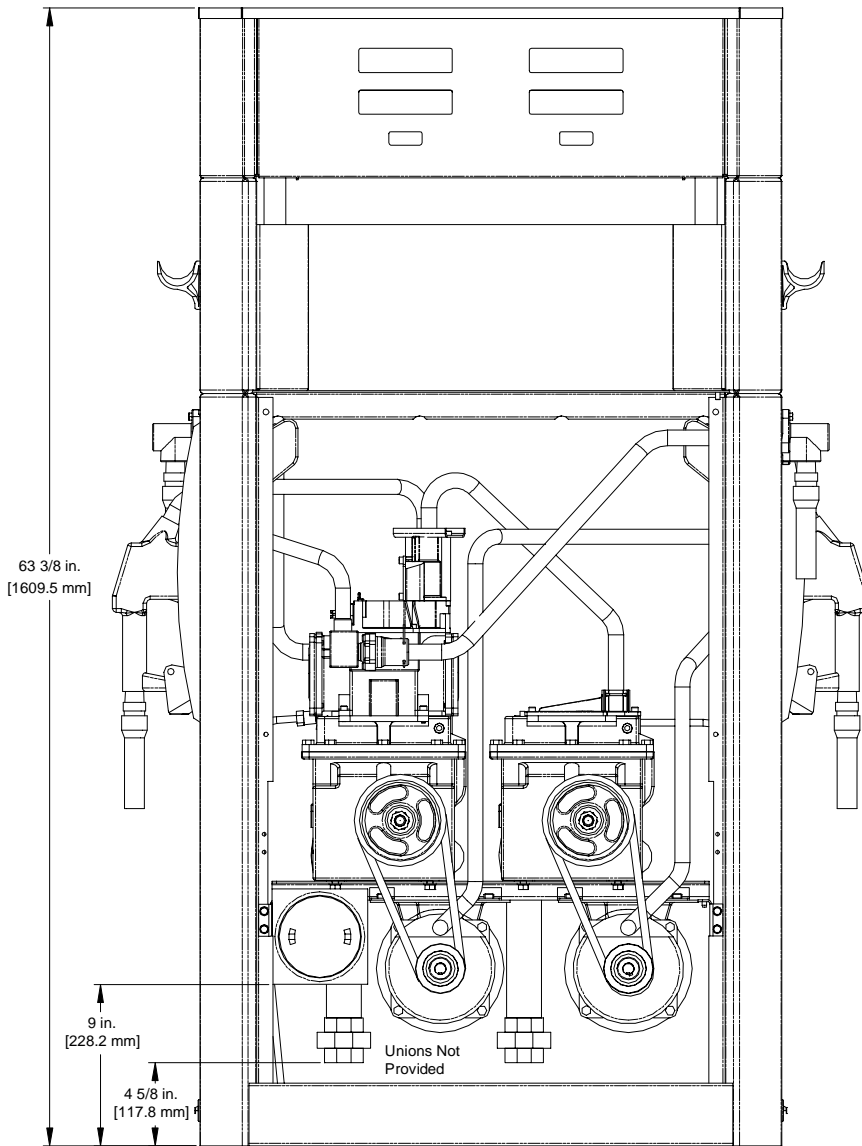

Base Orientation

3/G2203P/JK/W
Twin II Suction Pump
Island-Oriented

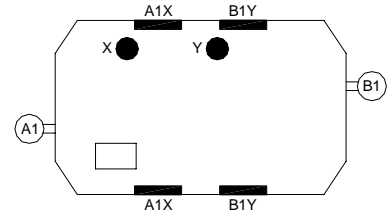

- Display
- Nozzle Boot
- Dispenser Inlet
- Main J-Box

The interior dimensions of the dispenser provide a maximum rectangular area of 16" x 29" for containment sumps (shown by dashed corners in the base layout).

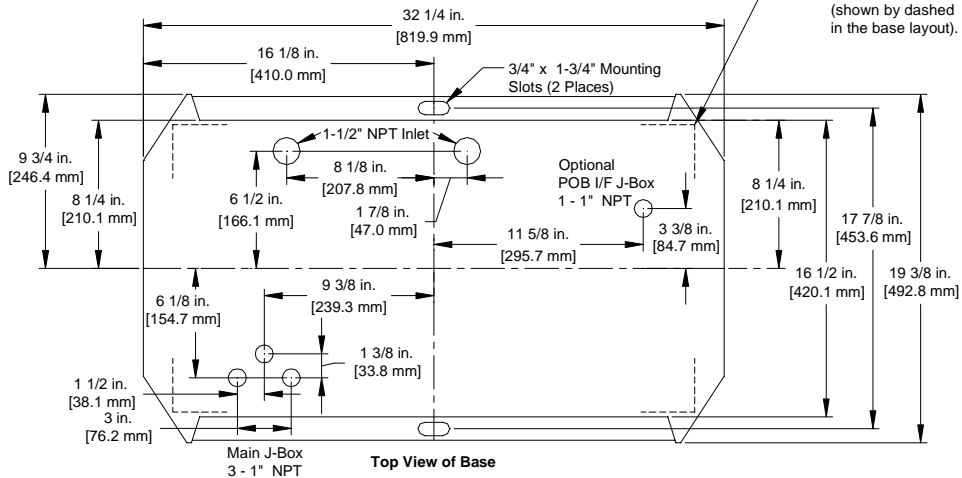



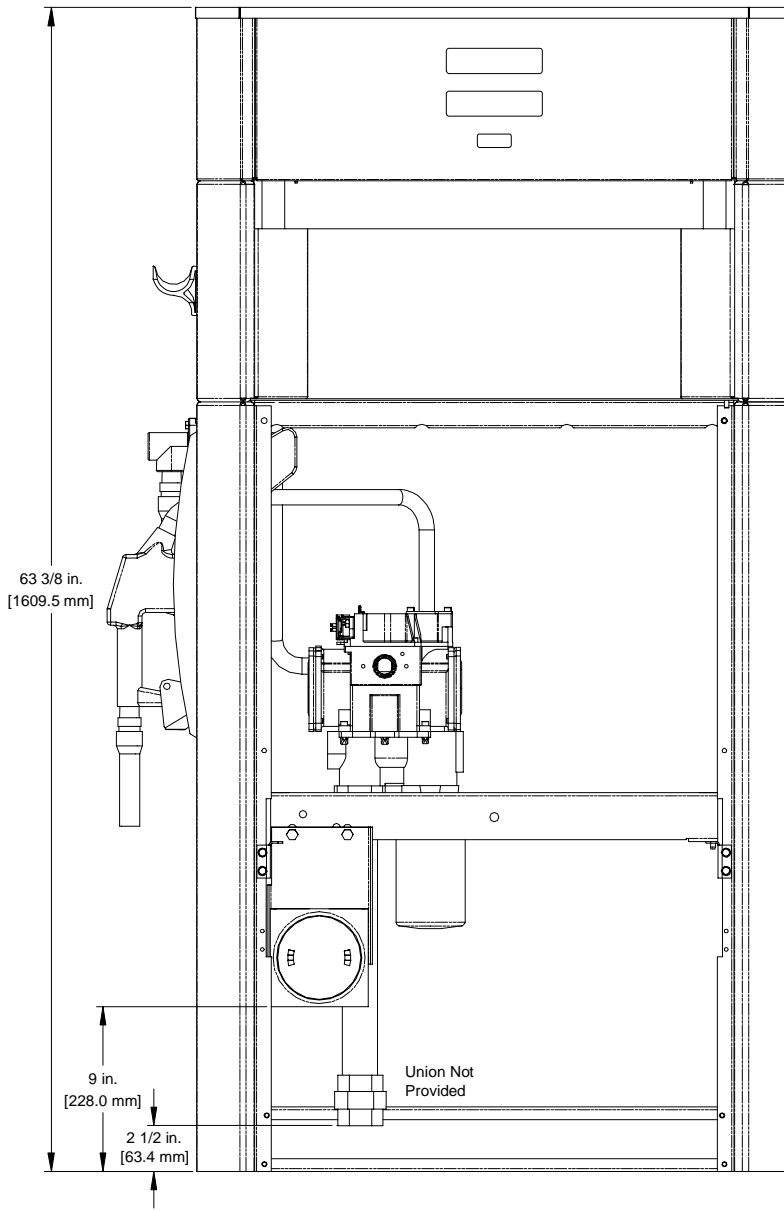

Models: 3/G2201D/GJK Single Remote Dispenser – Island

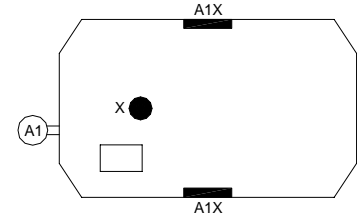

Base Orientation

3/G2201D/GJK
Single Remote
Island-Oriented



-  Display
-  Nozzle Boot
-  Dispenser Inlet
-  Main J-Box

The interior dimensions of the dispenser provide a maximum rectangular area of 16" x 29" for containment sumps (shown by dashed corners in the base layout).

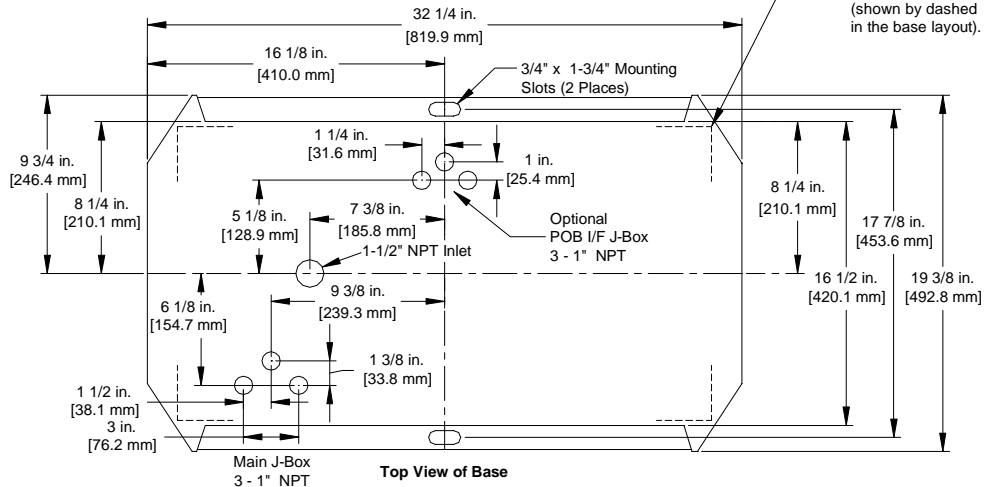

Models: 3/G2202D/GJK Twin I Remote Dispenser – Island
3/G2207D/GJK Twin I Remote Dispenser – Lane

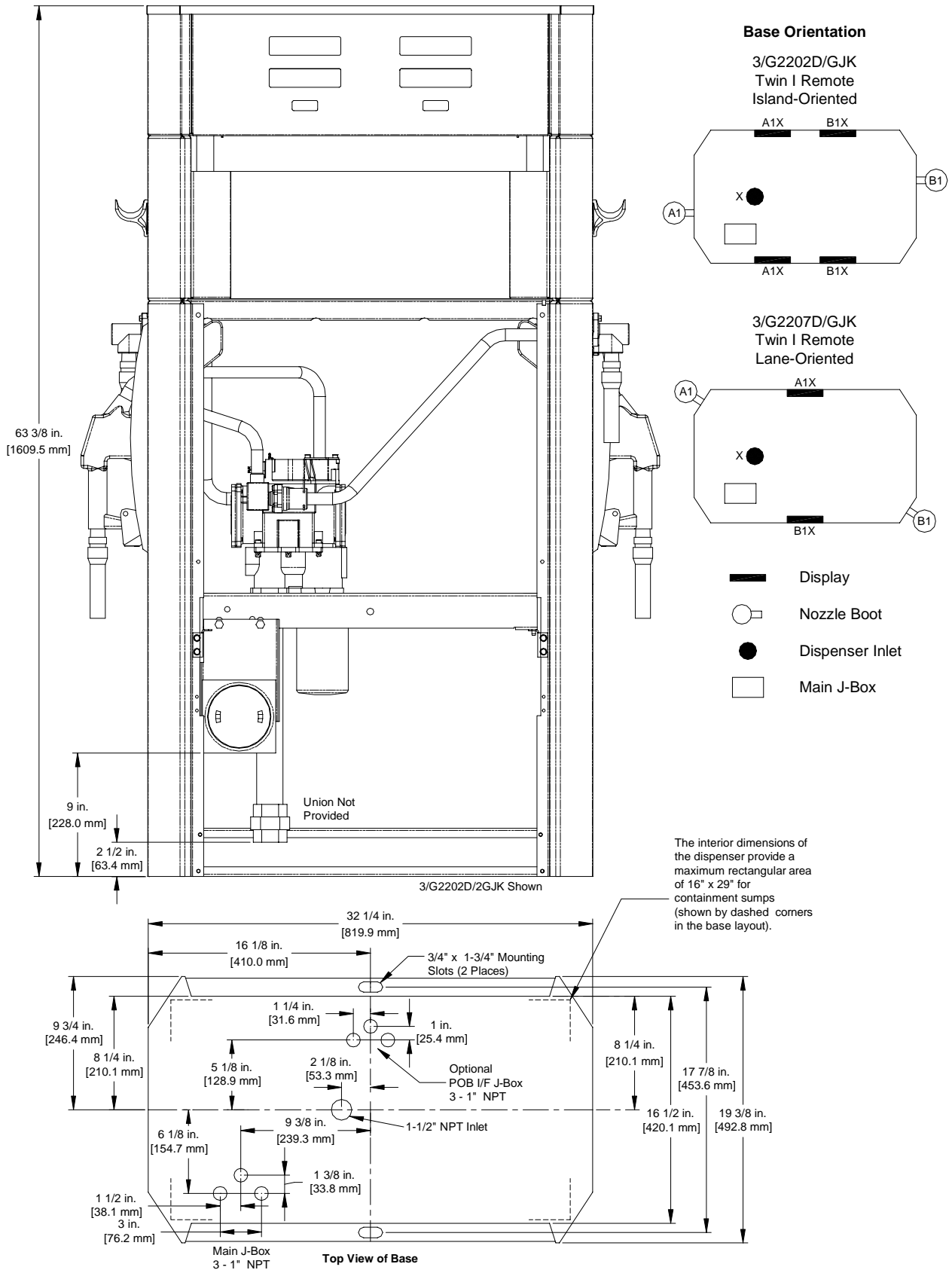

Models: 3/G2203D/GJK Twin II Remote Dispenser – Island

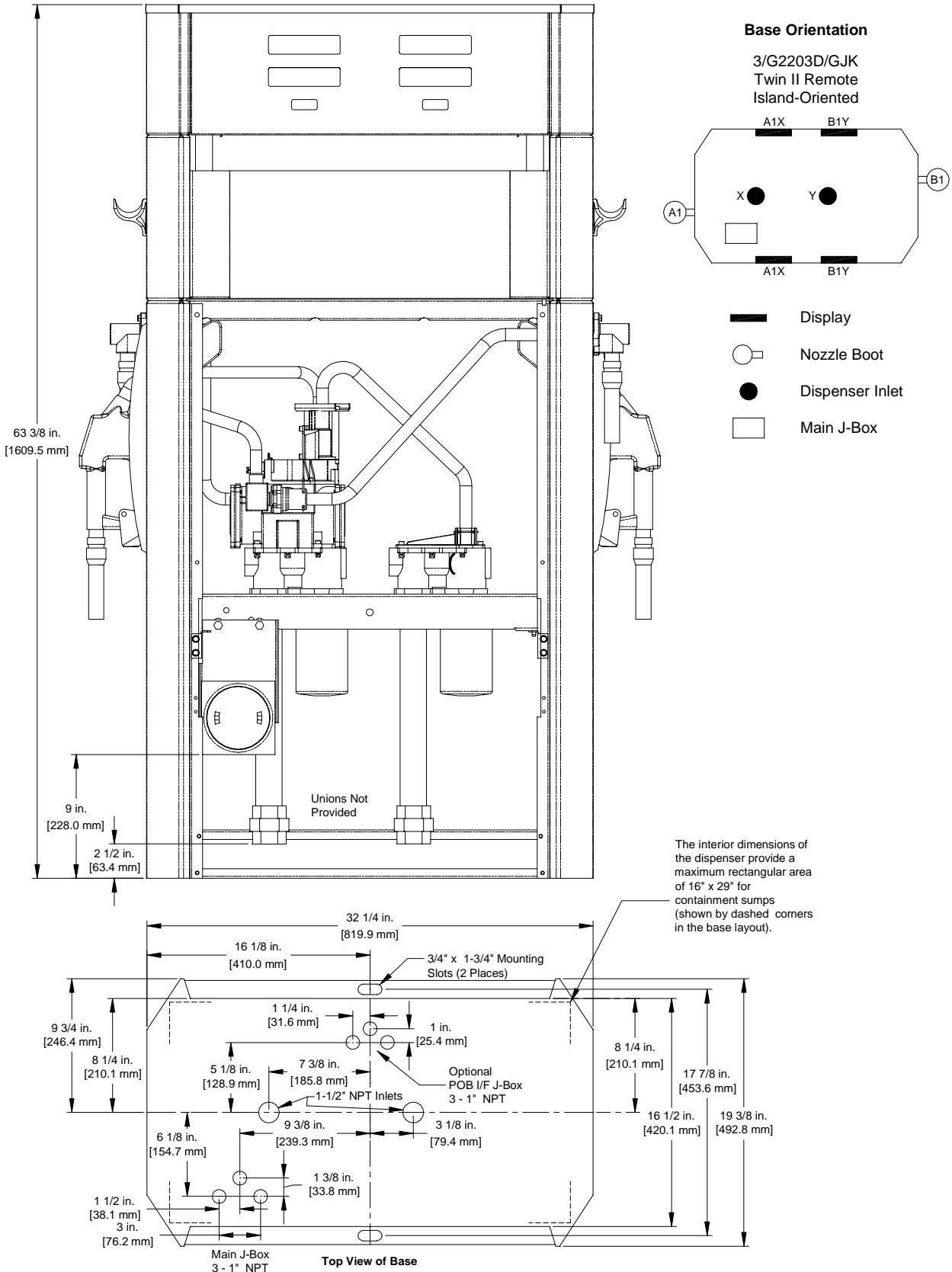

Models: 3/G2221D/GJK Super High Cap. Single Remote Dispenser – Island
3/G2227D/GJKR Super High Cap. Single Remote Dispenser – Lane

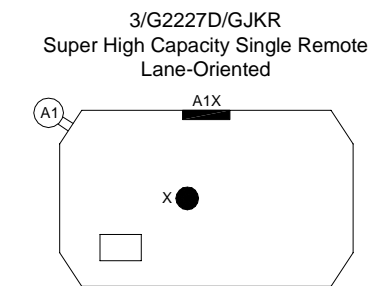
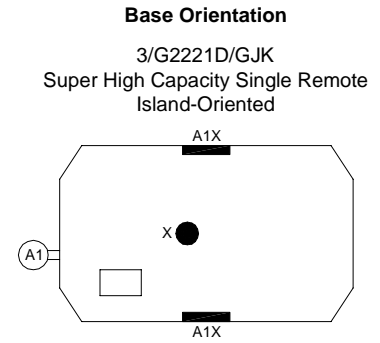
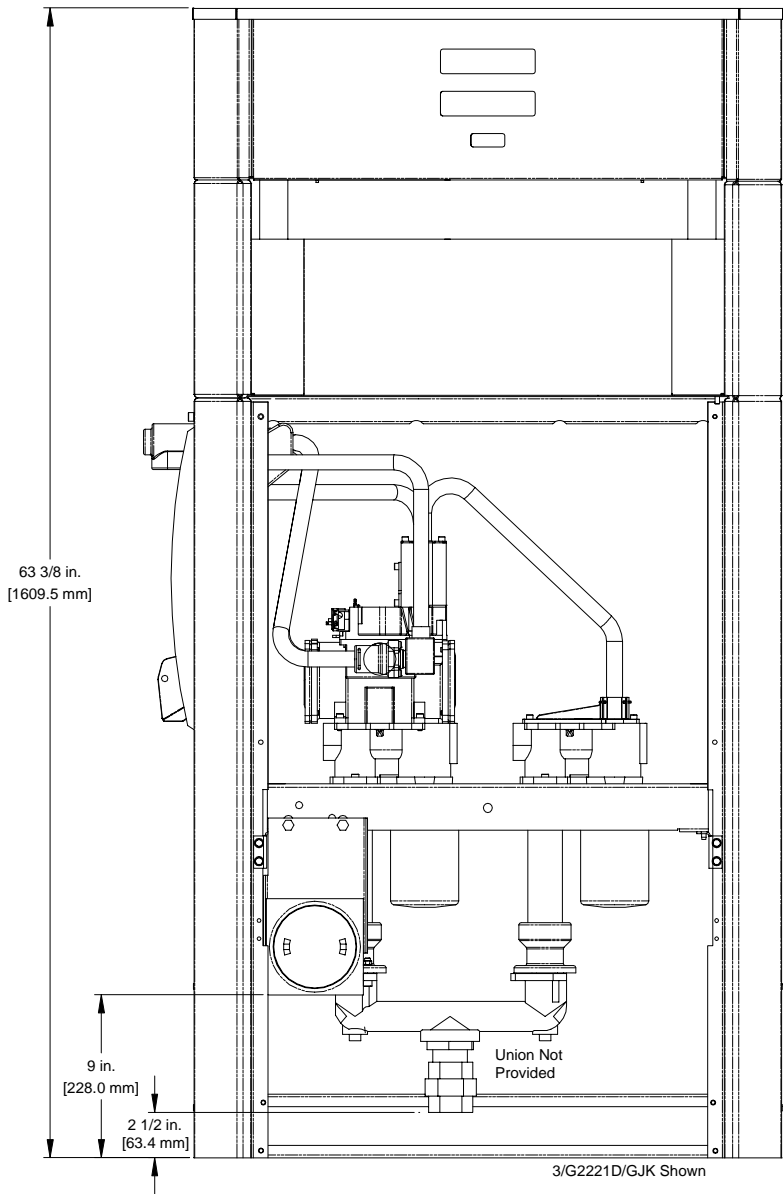

- Display
- Nozzle Boot
- Dispenser Inlet
- Main J-Box

The Hydraulic view for units with ATC, looks slightly different than what is shown to the left. The base layouts are the same.

The interior dimensions of the dispenser provide a maximum rectangular area of 16" x 29" for containment sumps (shown by dashed corners in the base layout).

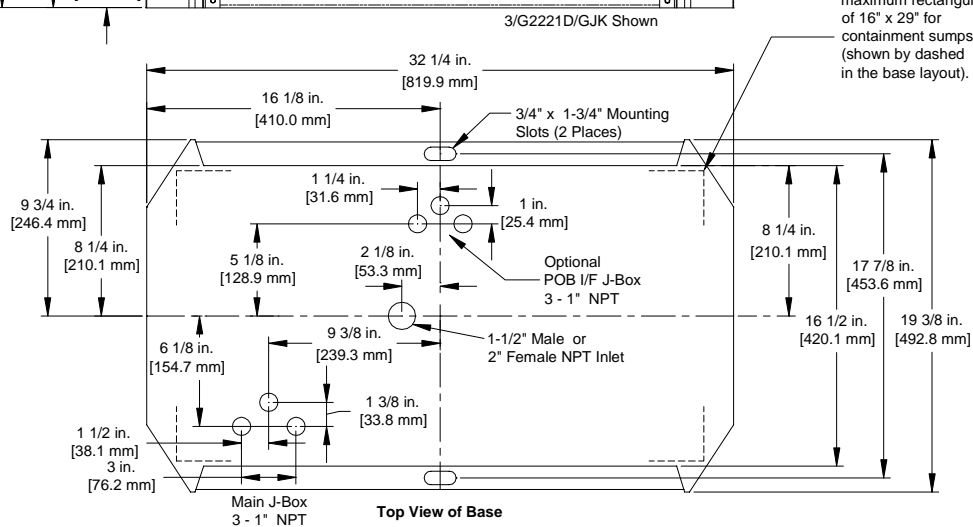

Model: 3/G2227D/GJKMR Super High Capacity Single Master Remote Dispenser – Lane

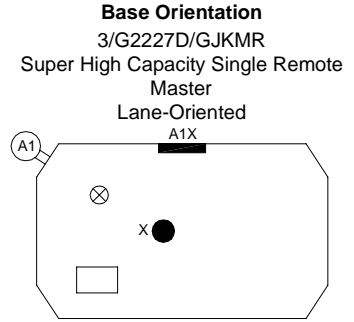
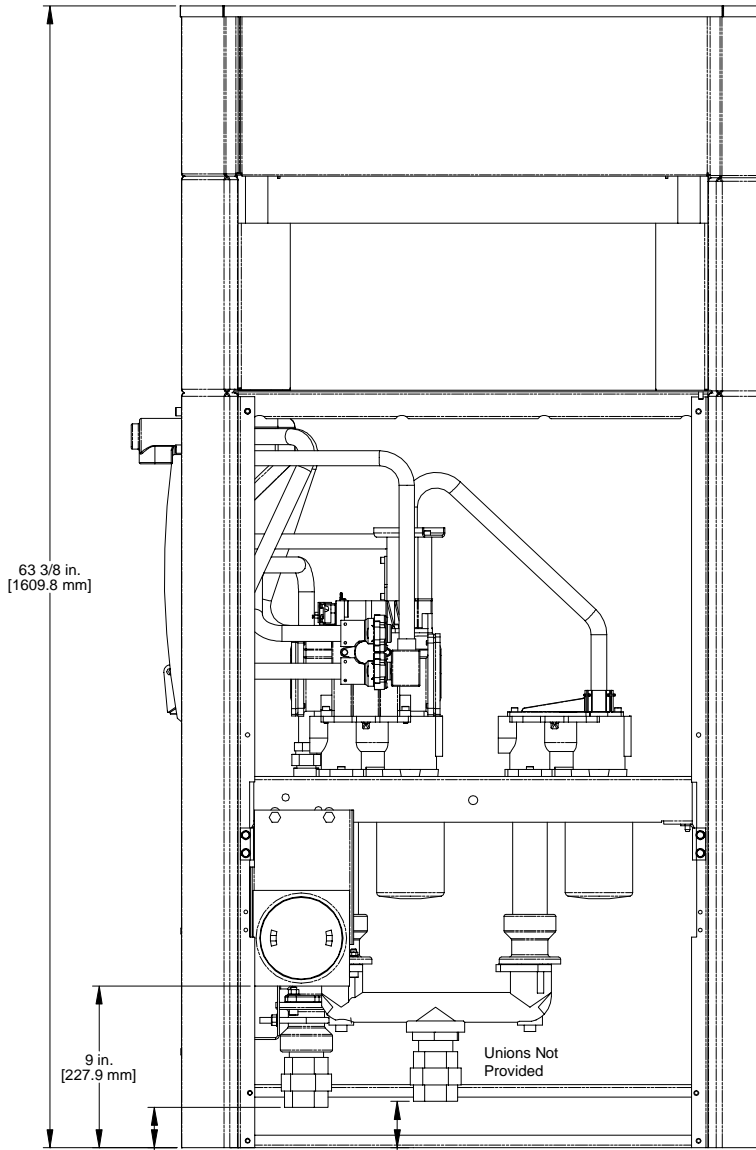

- Display
- Nozzle Boot
- Dispenser Inlet
- Main J-Box
- Satellite Outlet

When connected to a satellite, a Wayne Super High Capacity Satellite must be used.

The Hydraulic view for units with ATC, looks slightly different than what is shown to the left. The base layouts are the same.

The interior dimensions of the dispenser provide a maximum rectangular area of 16" x 29" for containment sumps (shown by dashed corners in the base layout).

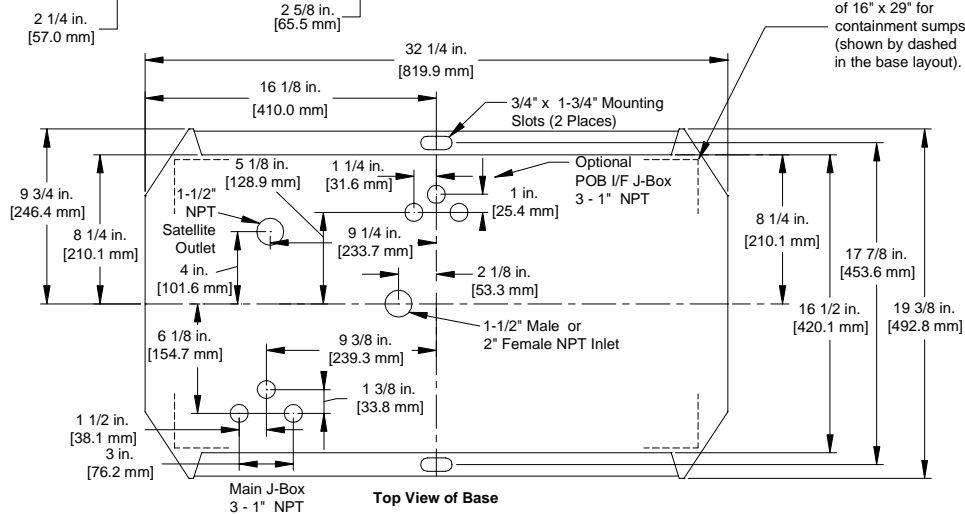

Models: 3/G2228D/GJKLM Super High Capacity Single Master Remote Dispenser & Satellite Combination - Lane

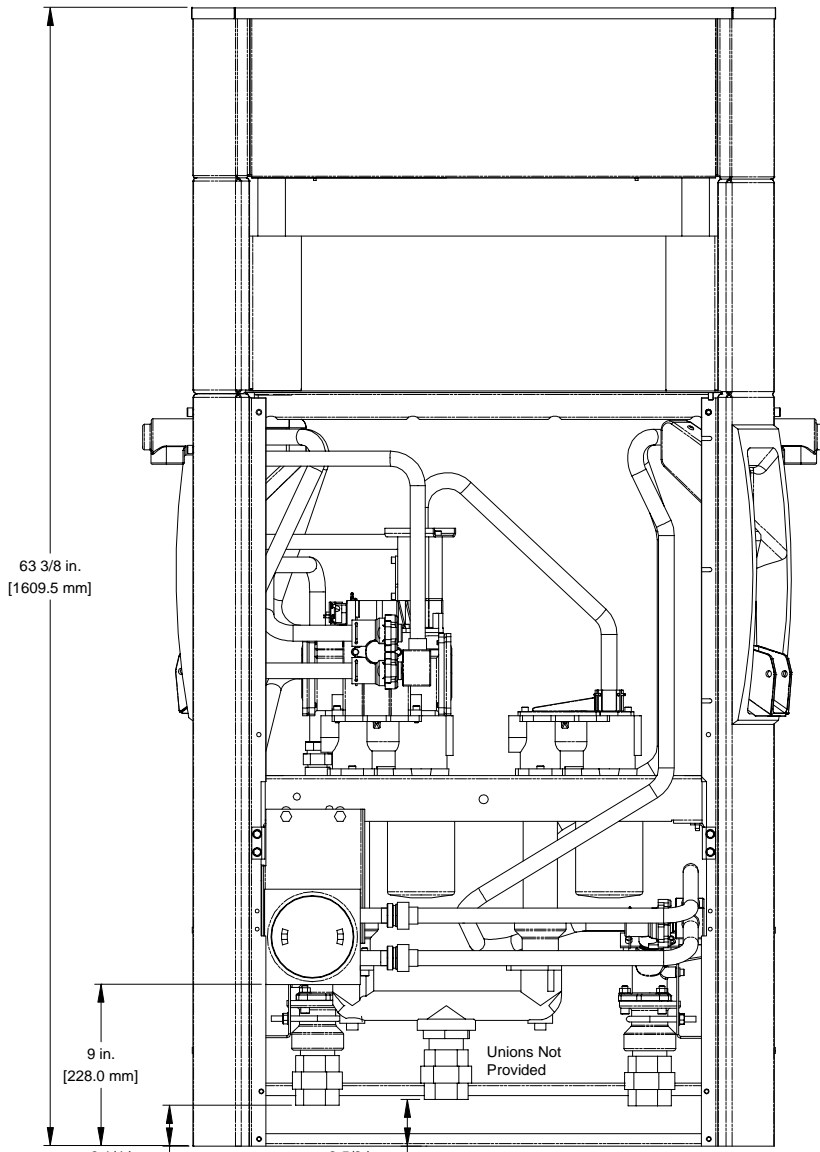

Base Orientation
 3/G2228D/GJKLM
 Super High Capacity Single Remote
 Master/Satellite
 Lane-Oriented

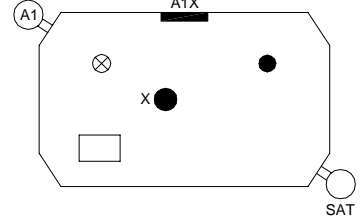

- Display
- Nozzle Boot
- Dispenser Inlet
- Main J-Box
- Satellite Inlet
- Satellite Outlet

When connected to a satellite, a Wayne Super High Capacity Satellite must be used.

The Hydraulic view for units with ATC, looks slightly different than what is shown to the left. The base layouts are the same.

The interior dimensions of the dispenser provide a maximum rectangular area of 16" x 29" for containment sumps (shown by dashed corners in the base layout).

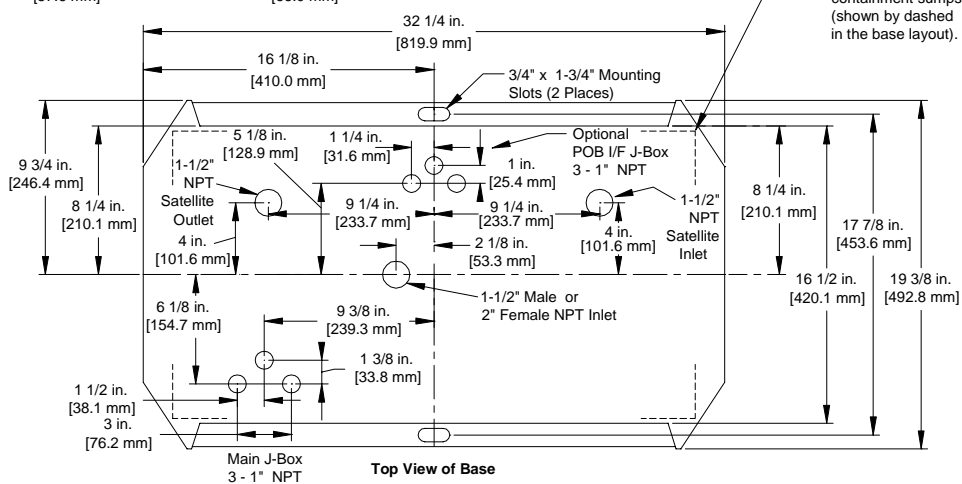

Model: 3/G2227D/GJK Super High Capacity Twin I Remote Dispenser – Lane

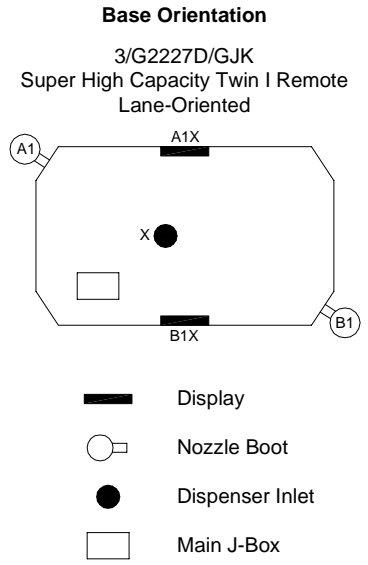
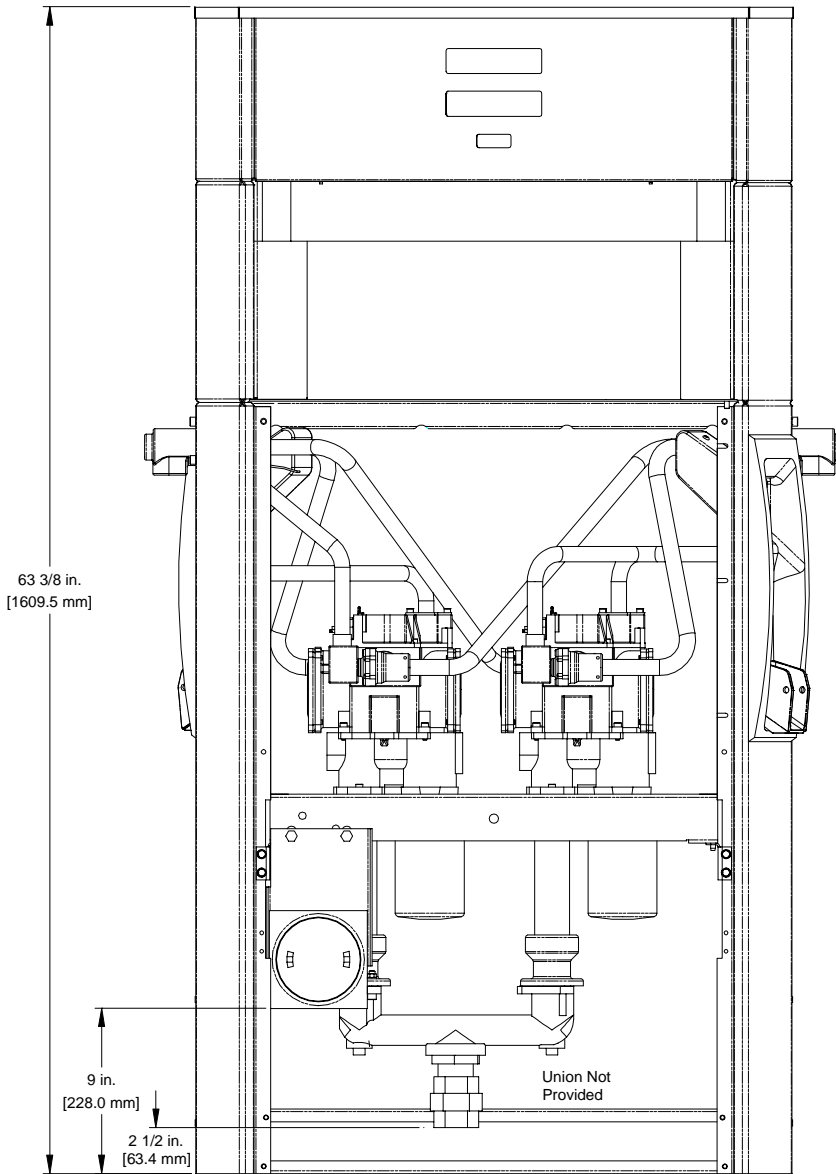

The interior dimensions of the dispenser provide a maximum rectangular area of 16" x 29" for containment sumps (shown by dashed corners in the base layout).

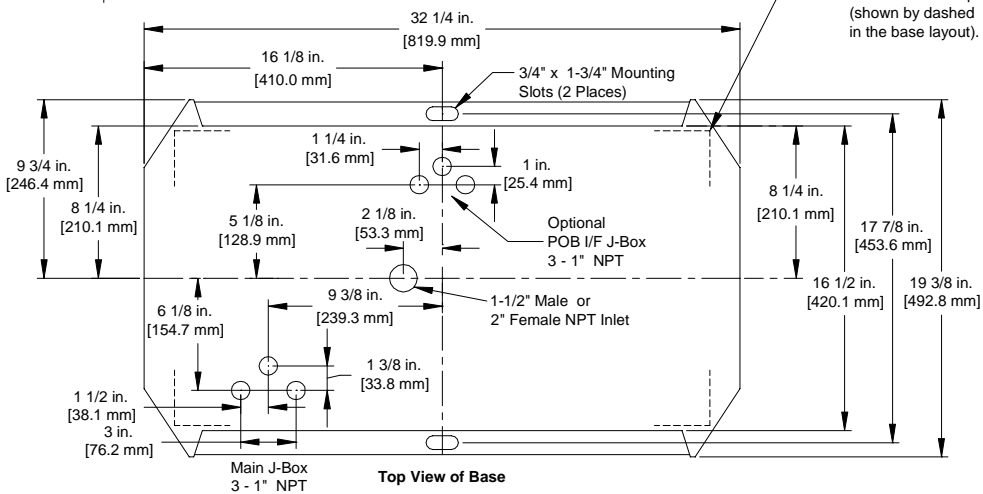

Model: 3/G2227D/GJKM Super High Capacity Twin I Master Remote Dispenser – Lane

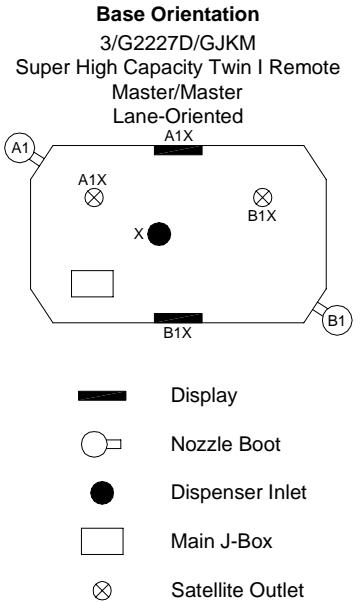
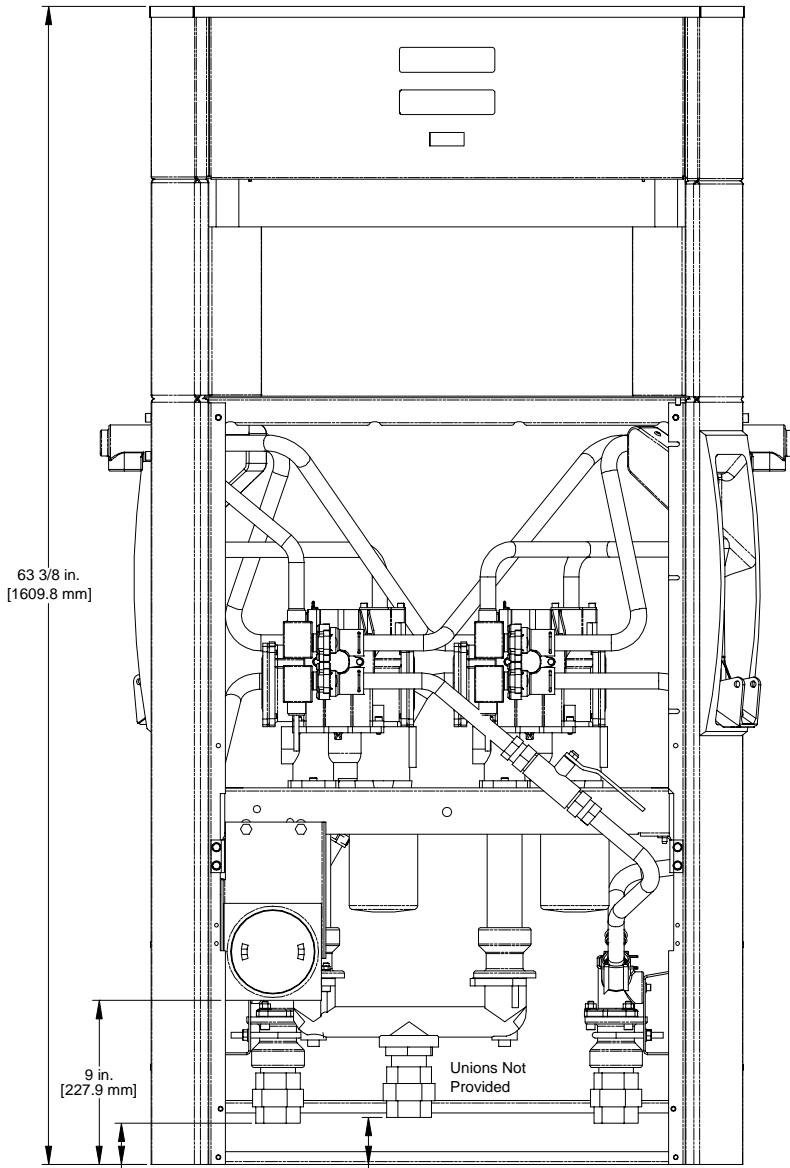

When connected to a satellite, a Wayne Super High Capacity Satellite must be used.

The interior dimensions of the dispenser provide a maximum rectangular area of 16" x 29" for containment sumps (shown by dashed corners in the base layout).

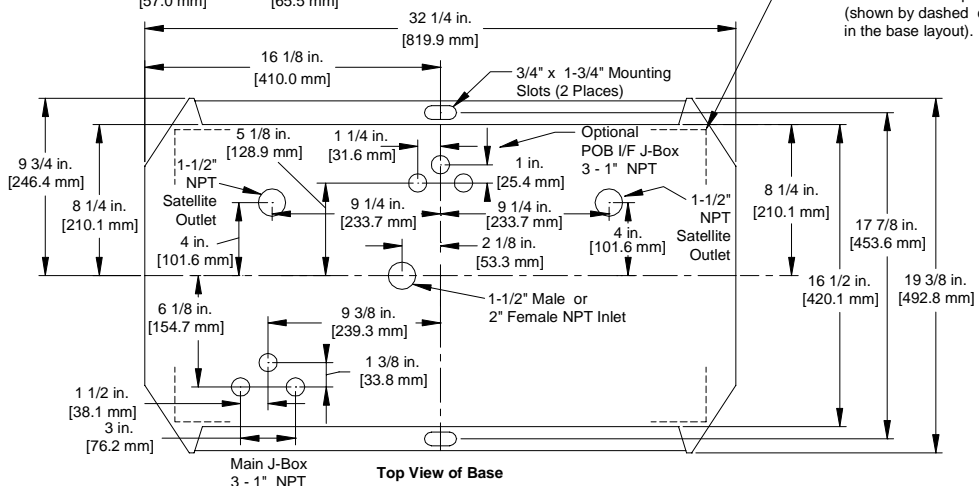

Models: 3/G2231D/GJK Ultra High Cap. Single Rem. Disp. – Island
3/G2237D/GJKMR Ultra High Cap. Single Rem. Master Disp. – Lane

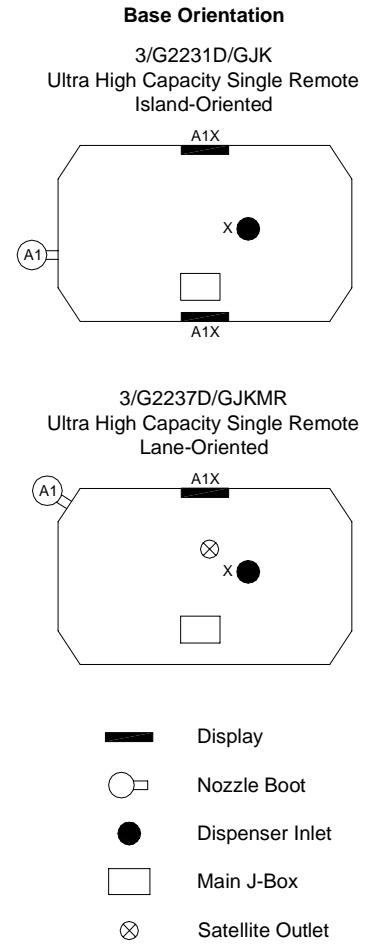
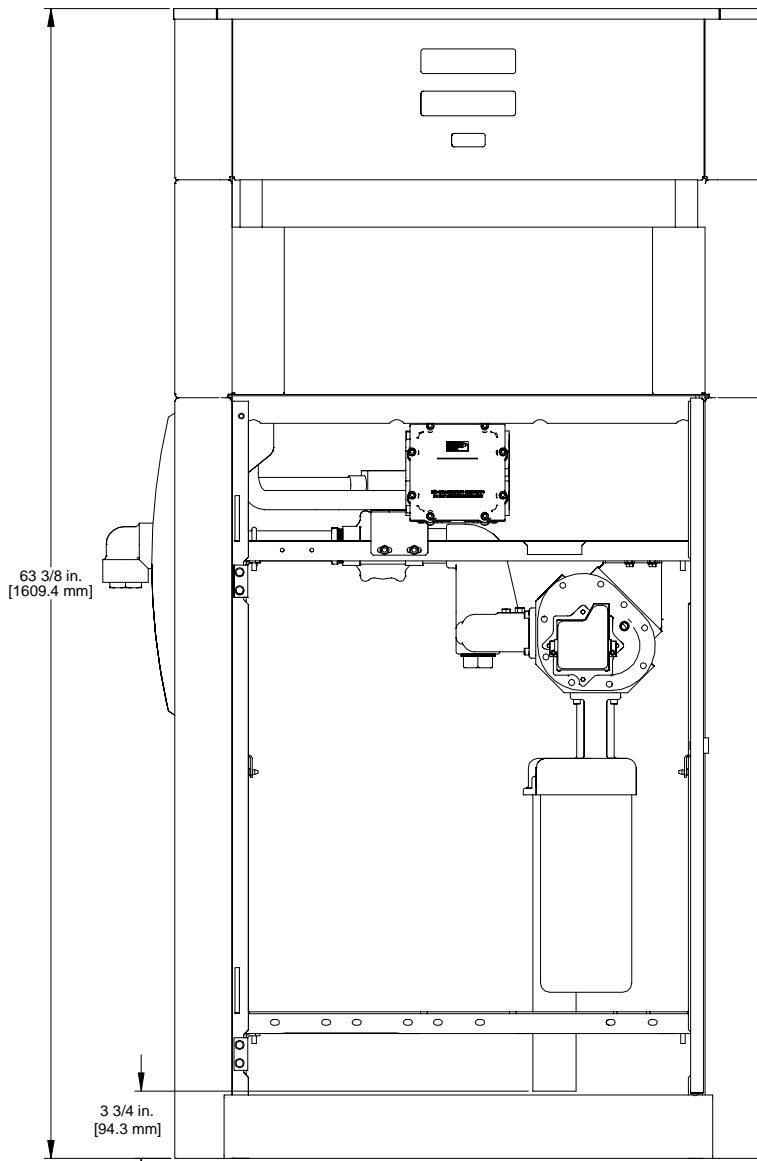

When connected to a satellite, a Wayne Ultra High Capacity Satellite must be used.

The interior dimensions of the dispenser provide a maximum rectangular area of 16" x 29" for containment sumps (shown by dashed corners in the base layout).

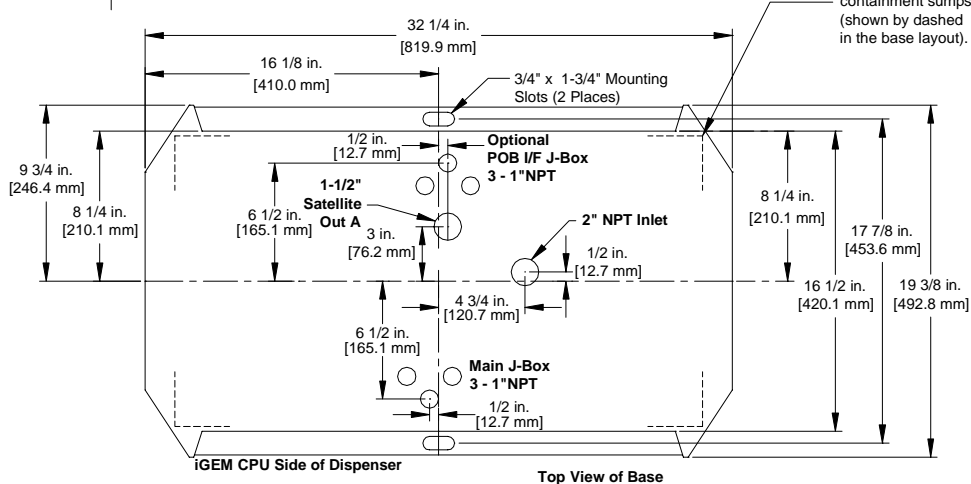

Models: 3/G2232D/GJK Ultra High Cap. Twin I Rem. Disp. – Island
3/G2237D/GJKM Ultra High Cap. Twin I Rem. Master Disp. – Lane

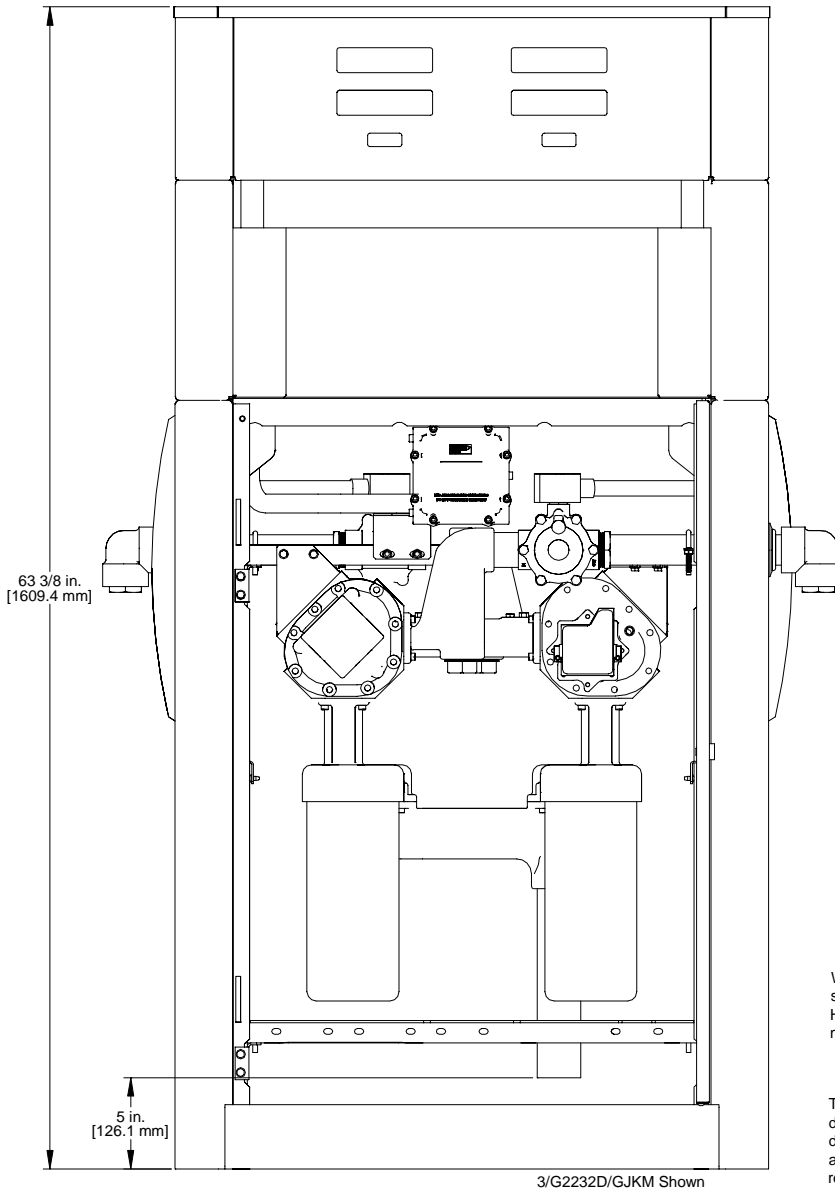





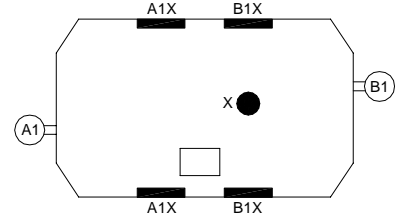

Base Orientation

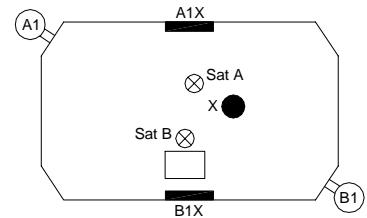
3/G2232D/GJK
 Ultra High Capacity Twin I Remote
 Island-Oriented



3/G2237D/GJKM
 Ultra High Capacity Twin I Remote
 Lane-Oriented



-  Display
-  Nozzle Boot
-  Dispenser Inlet
-  Main J-Box
-  Satellite Outlet

When connected to a satellite, a Wayne Ultra High Capacity Satellite must be used.

The interior dimensions of the dispenser provide a maximum rectangular area of 16" x 29" for containment sumps (shown by dashed corners in the base layout).

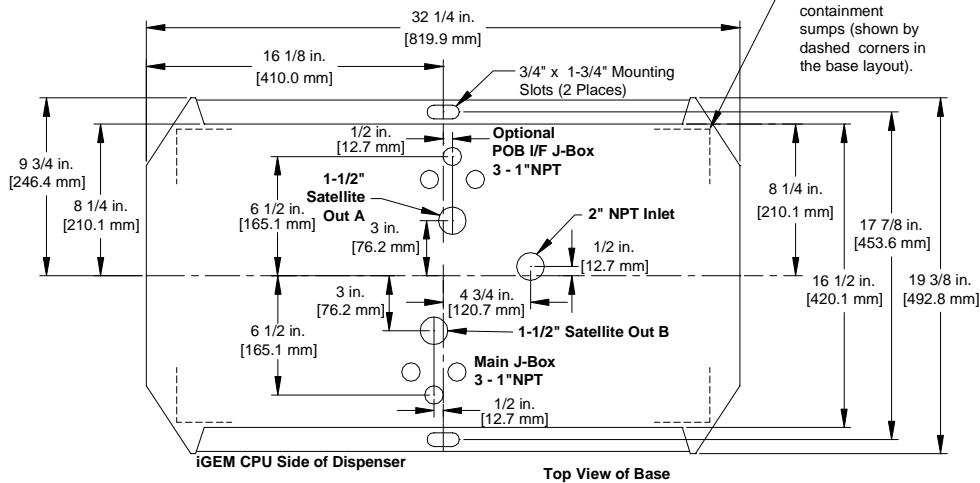

Models: 3/G2233D/GJK Ultra High Cap. Twin II Rem. Disp. – Island
3/G2238D/GJKM Ultra High Cap. Twin II Rem. Master Disp. – Lane
3/G2239D/GJKMR Ultra High Cap. Twin II Rem. Master Disp. – Lane
Single - Sided

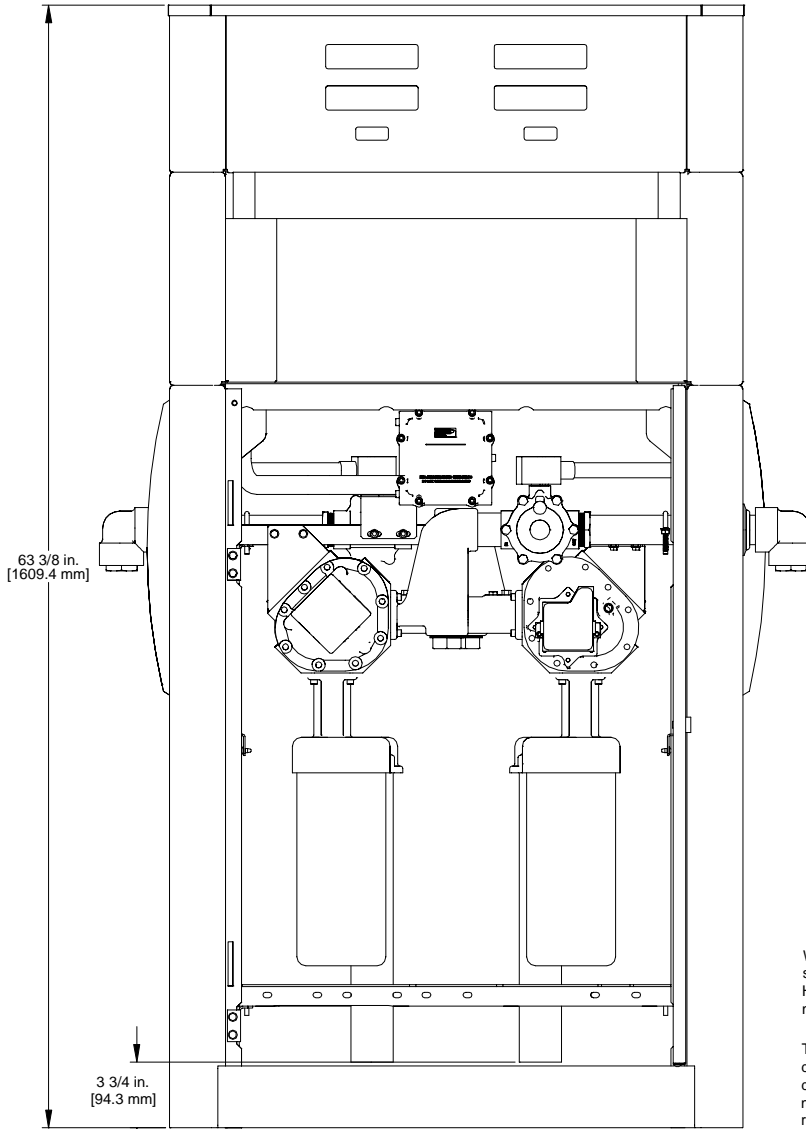

Base Orientation

3/G2233D/GJK
 Ultra High Capacity Twin II Remote
 Island-Oriented

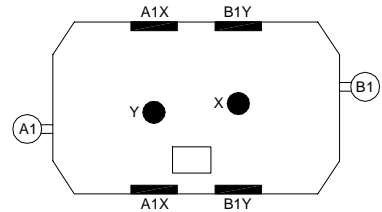

3/G2238D/GJKM
 Ultra High Capacity Twin II Remote
 Lane-Oriented

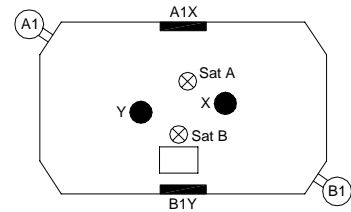



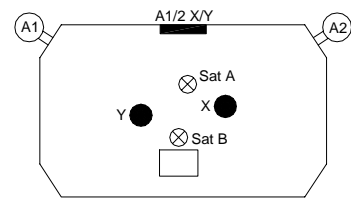

3/G2239D/GJKMR
 Ultra High Capacity Twin II Remote
 Lane-Oriented, Single-Sided



When connected to a satellite, a Wayne Ultra High Capacity Satellite must be used.

The interior dimensions of the dispenser provide a maximum rectangular area of 16" x 29" for containment sumps (shown by dashed corners in the base layout).

-  Display
-  Nozzle Boot
-  Dispenser Inlet
-  Main J-Box
-  Satellite Outlet

Alternate 2" Inlet Note:
 Recommended for Masters with satellite piping.
 This alternate inlet position may be obtained by remounting the dual filter inlet casting 180° from the supplied orientation. This creates more room between the inlet piping connections, and may simplify the installation of emergency impact valves.

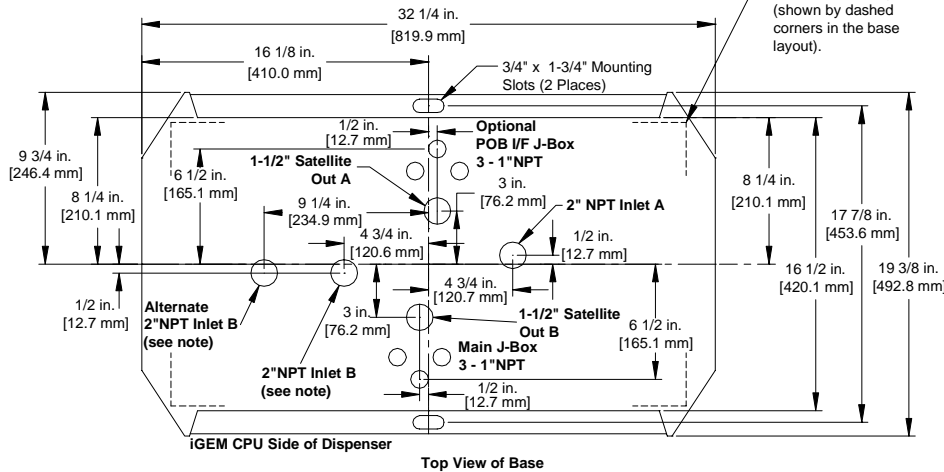

Model: 3/G2238D/GJKLM Ultra High Capacity Combo, Single Remote Master Dispenser & Satellite – Lane

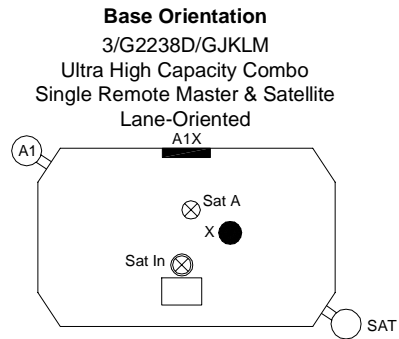
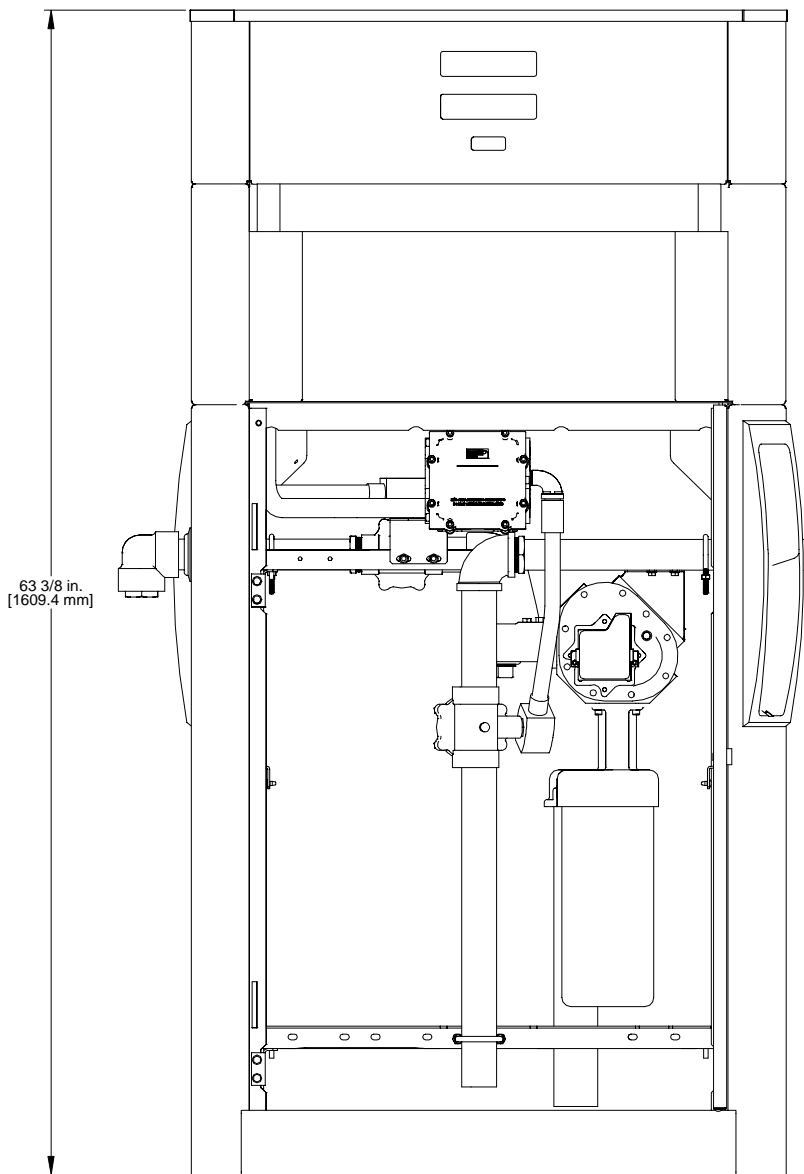

- Display
- Nozzle Boot
- Dispenser Inlet
- Main J-Box
- Satellite Outlet
- Satellite Inlet

When connected to a satellite, a Wayne Ultra High Capacity Satellite must be used.

The interior dimensions of the dispenser provide a maximum rectangular area of 16" x 29" for containment sumps (shown by dashed corners in the base layout).

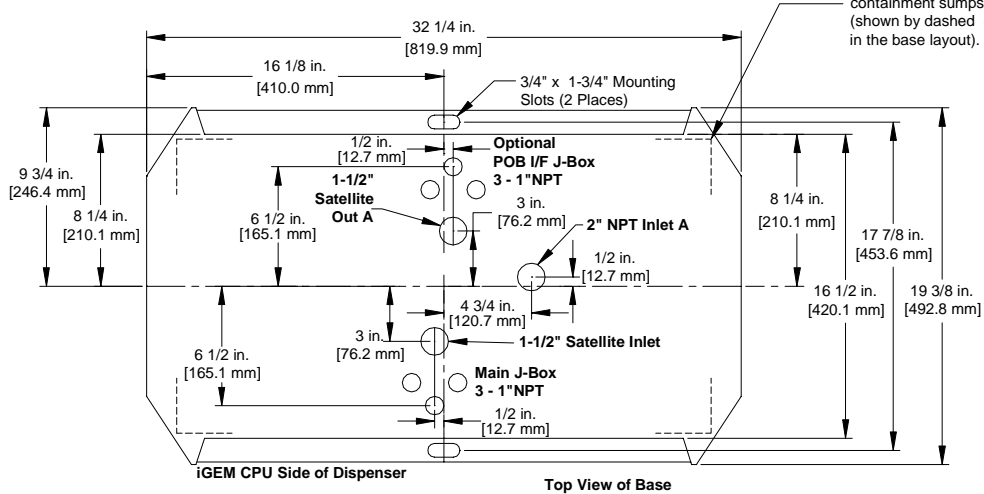

Side View (Nozzle Side) – All Century Series Models (except Satellites)

Island-Oriented
Side Load

Lane-Oriented
Front Load

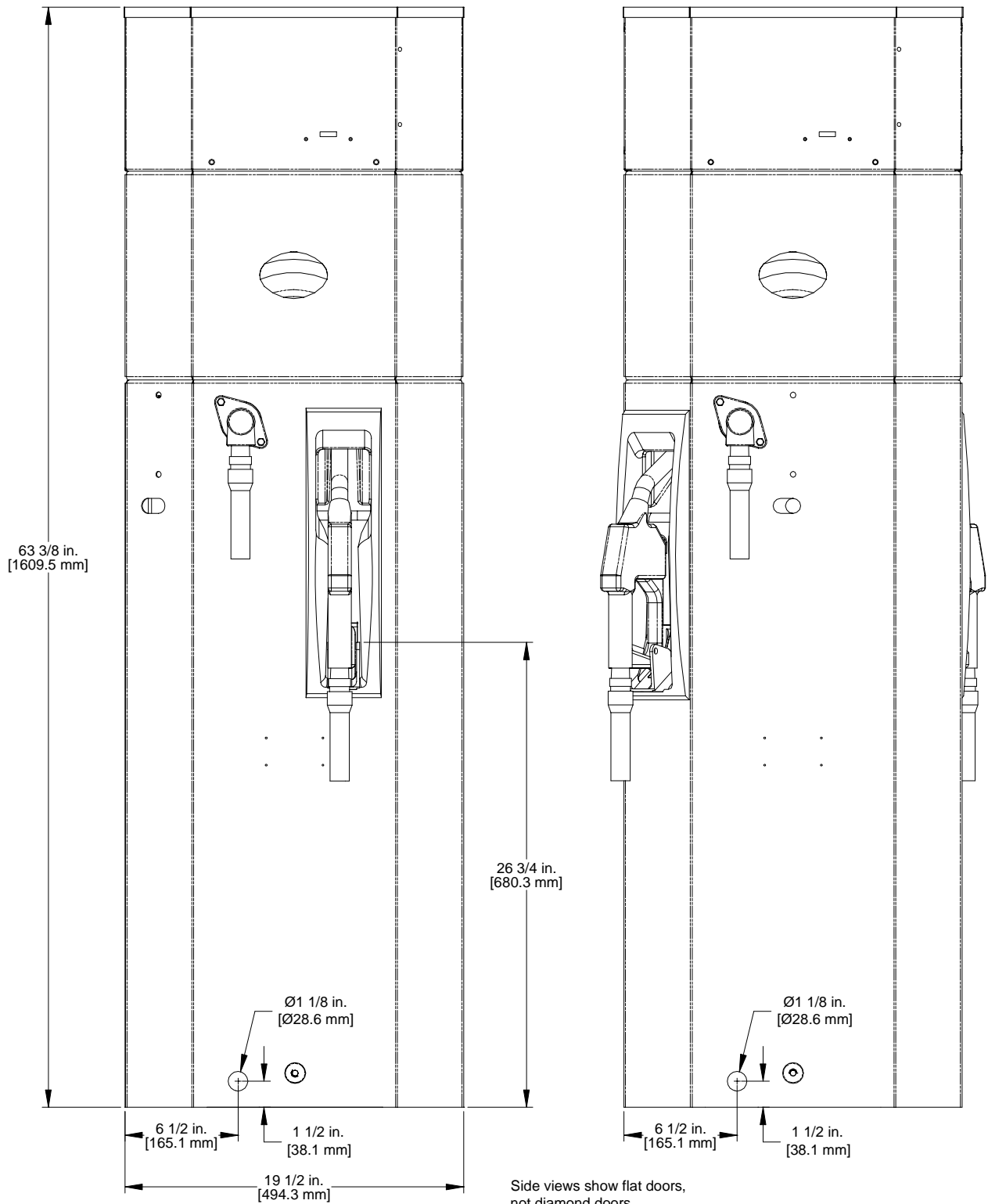



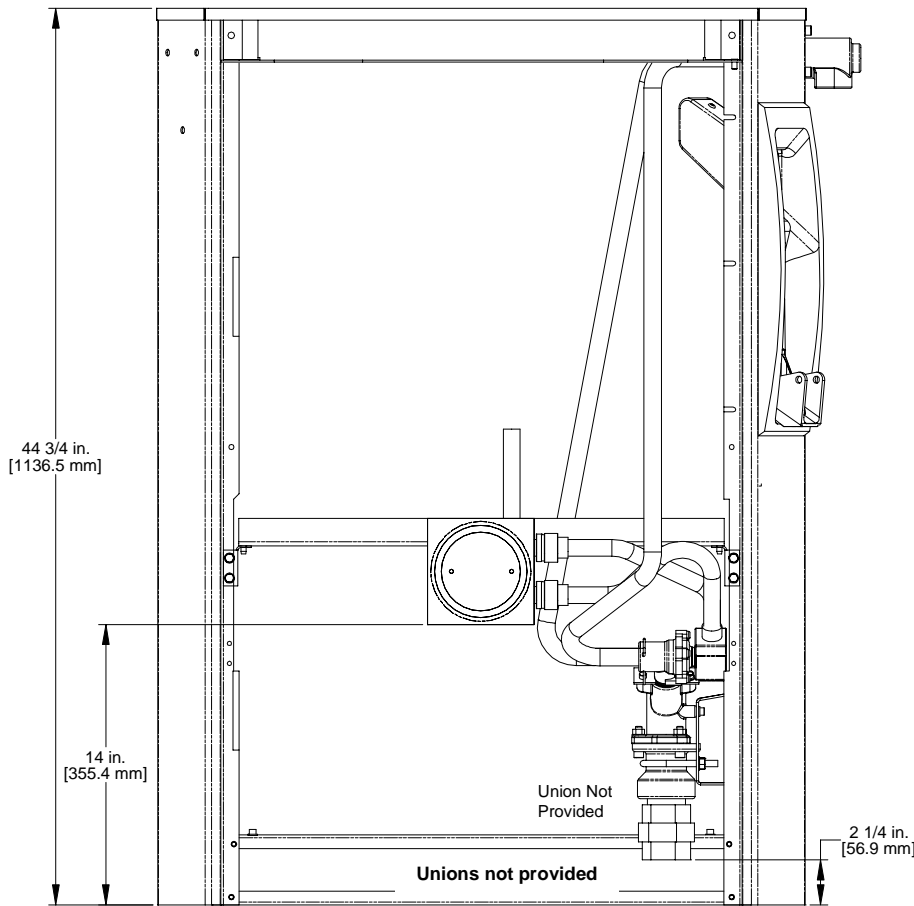

Model: 3/G2007/JKLR Super High Capacity, Single Satellite Disp. – Lane

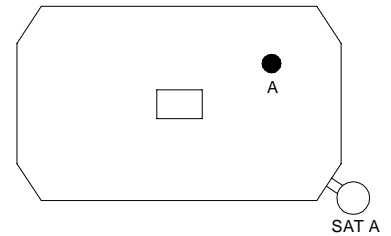

Base Orientation

3/G2007/JKLR
Single Satellite
Lane-Oriented



-  Nozzle Boot
-  J-Box
-  Satellite Inlet

Note: The interior dimensions of the dispenser provide a maximum rectangular area of 16" x 29" for containment sumps (shown by dashed corners in the base layout).

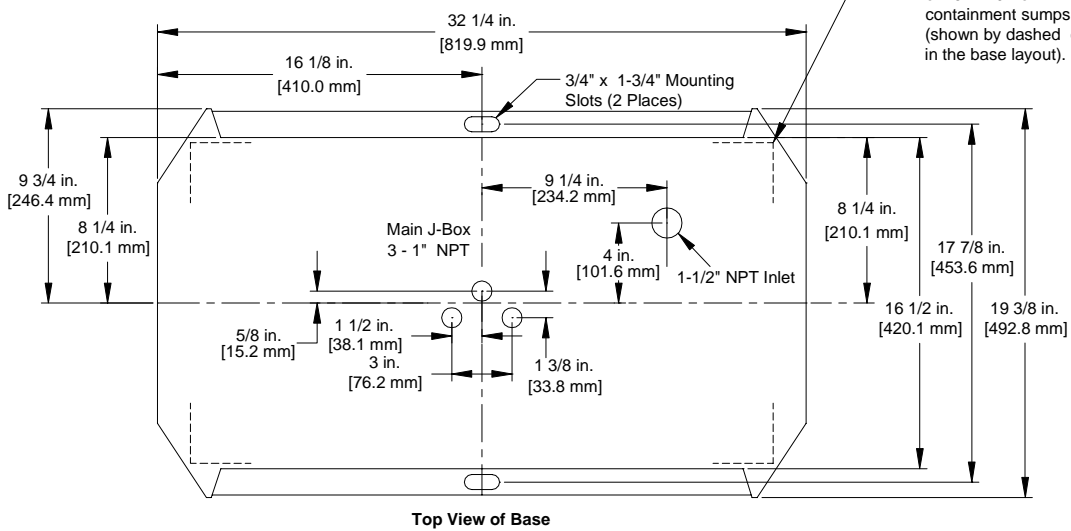

Model: 3/G2008/JKL Super High Capacity, Twin Satellite Dispenser – Lane

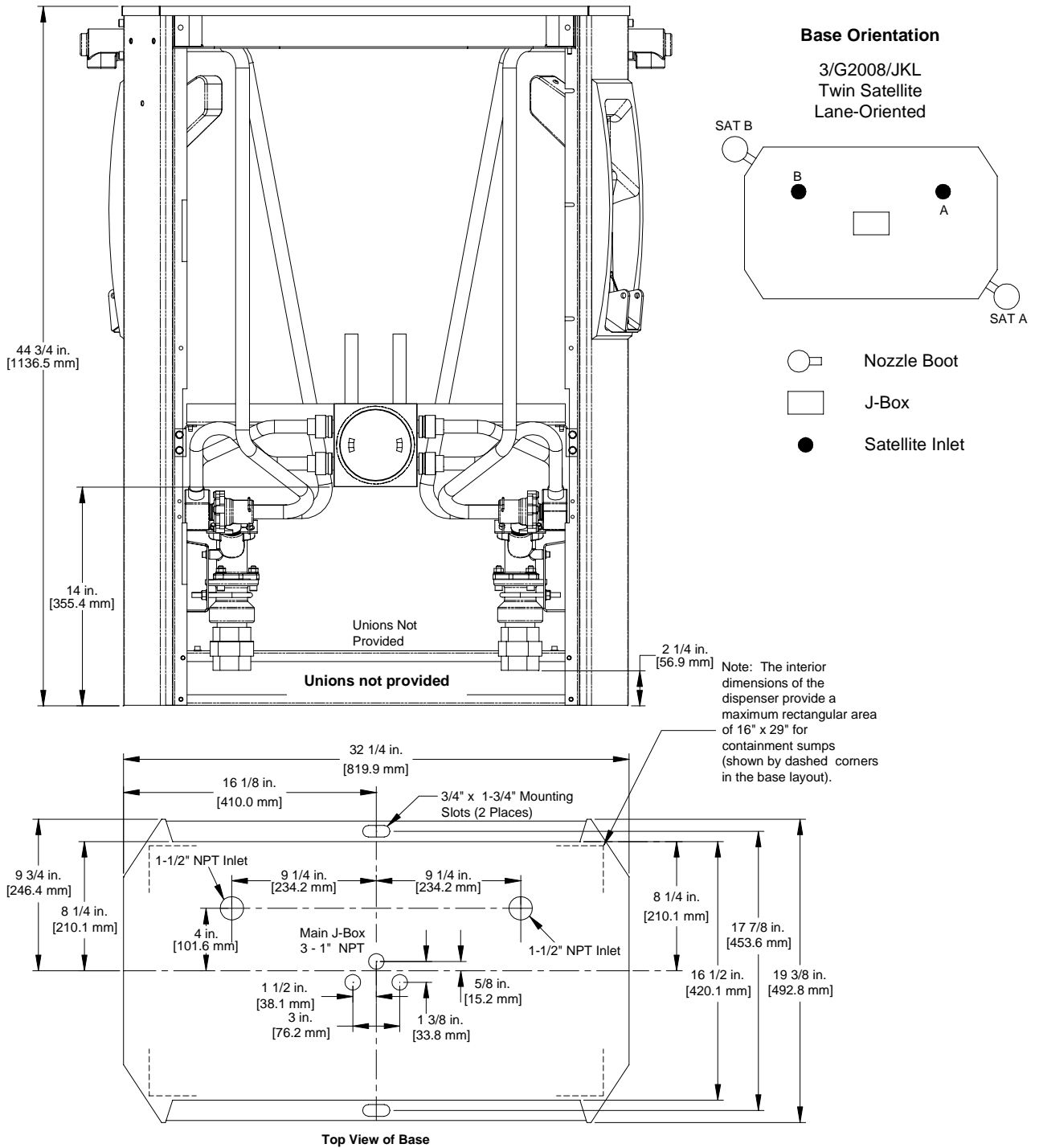

Models: 3/G2037/JKLR Ultra High Capacity, Single Satellite - Lane

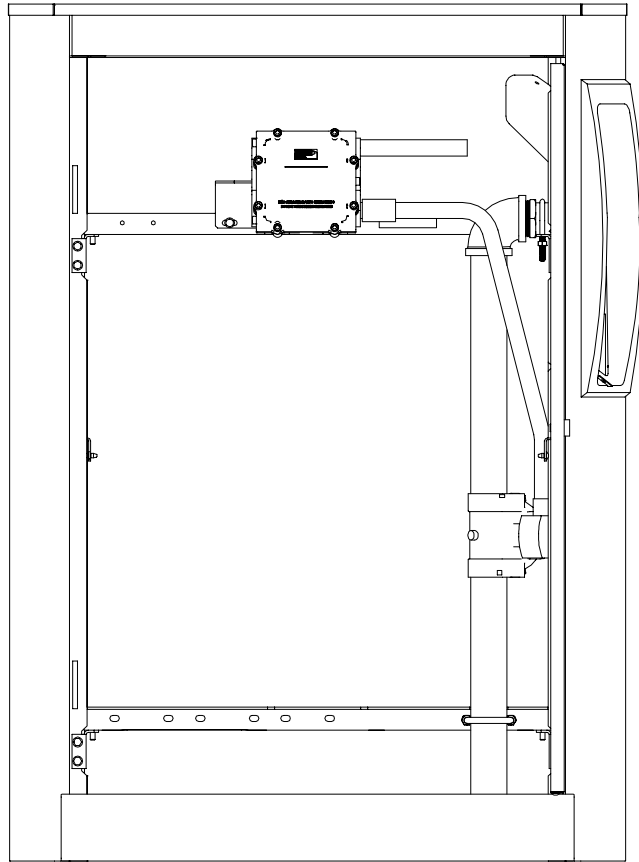



3/G7037/JKLR Shown

Base Orientation

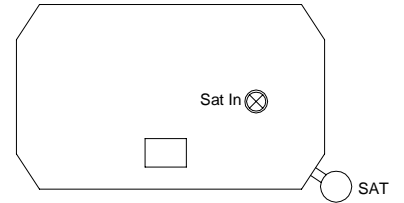
3/G2037/JKLR
Ultra High Capacity Single Satellite
Lane-Oriented



-  Nozzle Boot
-  Main J-Box
-  Satellite Inlet

Note: The interior dimensions of the dispenser provide a maximum rectangular area of 16" x 29" for containment sumps (shown by dashed corners in the base layout).

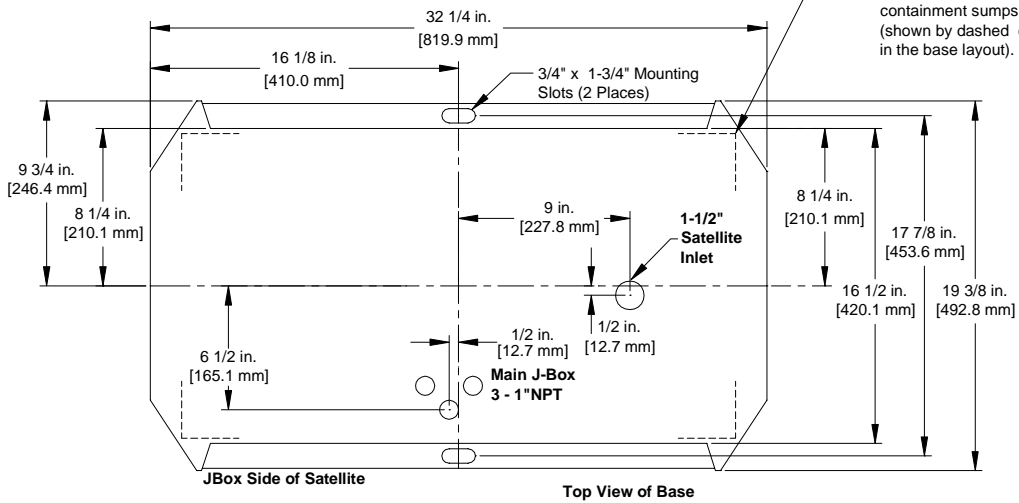

Models: 3/G2038/JKL
3/G2039/JKLR

Ultra High Capacity, Twin Satellite - Lane
Ultra High Capacity, Twin Satellite - Lane,
Single-Sided

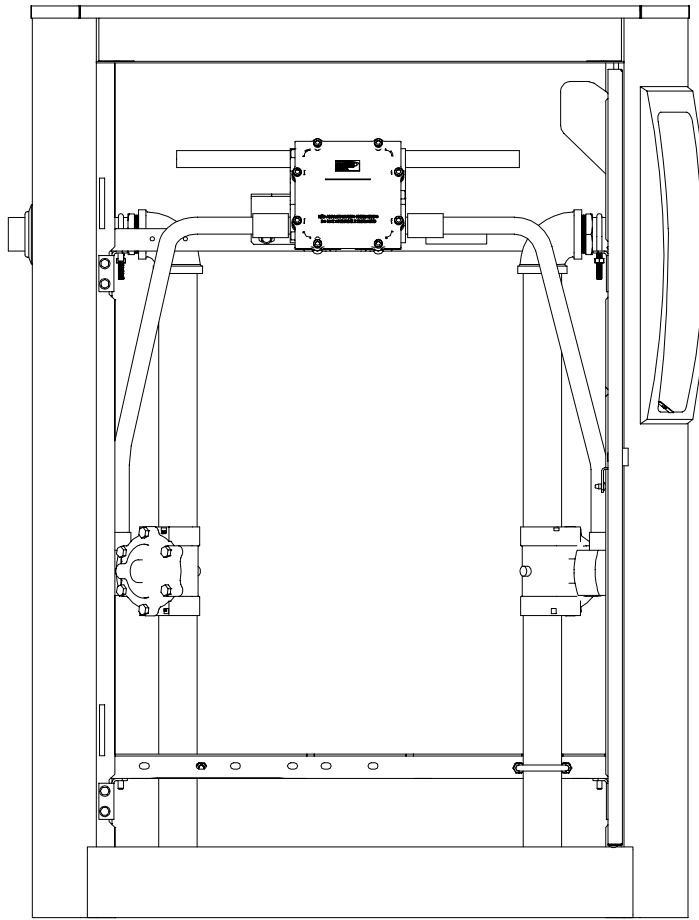

3/G7038/JKL Shown

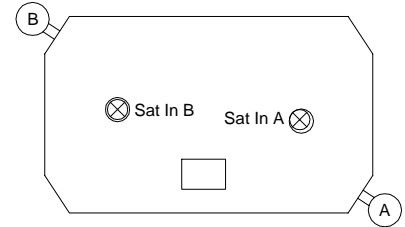

Base Orientation

3/G2038/JKL
Ultra High Capacity Twin Satellite
Lane-Oriented

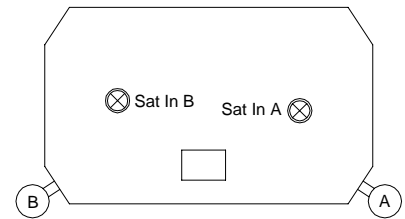

3/G2039/JKLR
Ultra High Capacity Twin Satellite
Lane-Oriented, Single-Sided



-  Nozzle Boot
-  Main J-Box
-  Satellite Inlet

Note: The interior dimensions of the dispenser provide a maximum rectangular area of 16" x 29" for containment sumps (shown by dashed corners in the base layout).

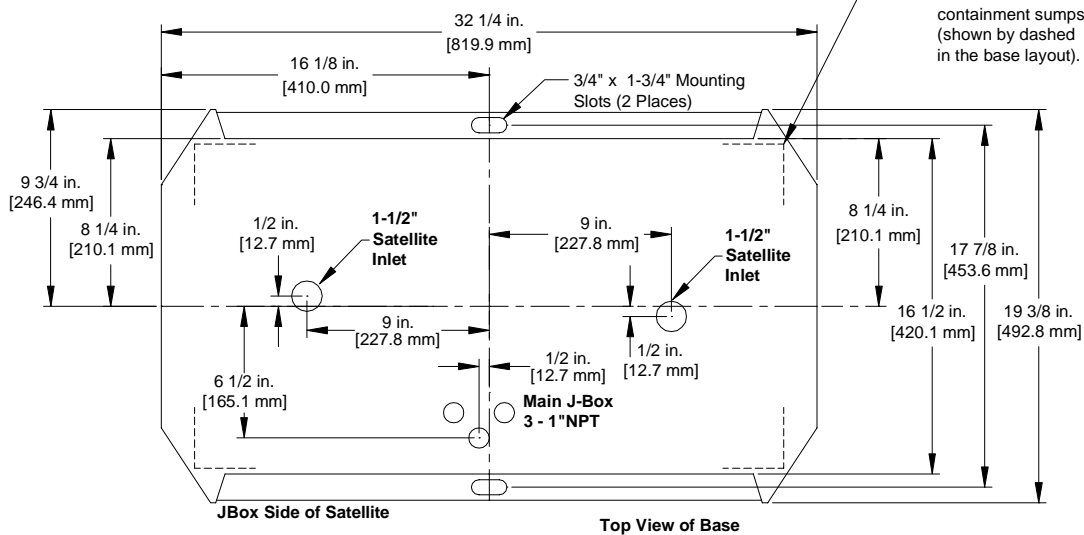

APPENDIX B

ELECTRICAL RATINGS & WIRING DIAGRAMS

Electrical Ratings

Component	Voltage	Amps
Dispenser Control Power	120VAC 50/60 Hz	1 Amp
	240VAC 50/60 Hz	1 Amp
Light Power	120VAC 50/60 Hz	.6 Amp
	240VAC 50/60 Hz	.6 Amp
Suction Pump Motor – 1 HP	120VAC 60 Hz	12.4 Amps
	240VAC 60 Hz	6.2 Amps
	240VAC 50 Hz	7.3 Amps

Wiring Diagram:

3/G2201P/JK Single Suction Pump (Island)

3/G2202P/JK & 3/G2207P/JK Twin I Suction Pump (Island & Lane)

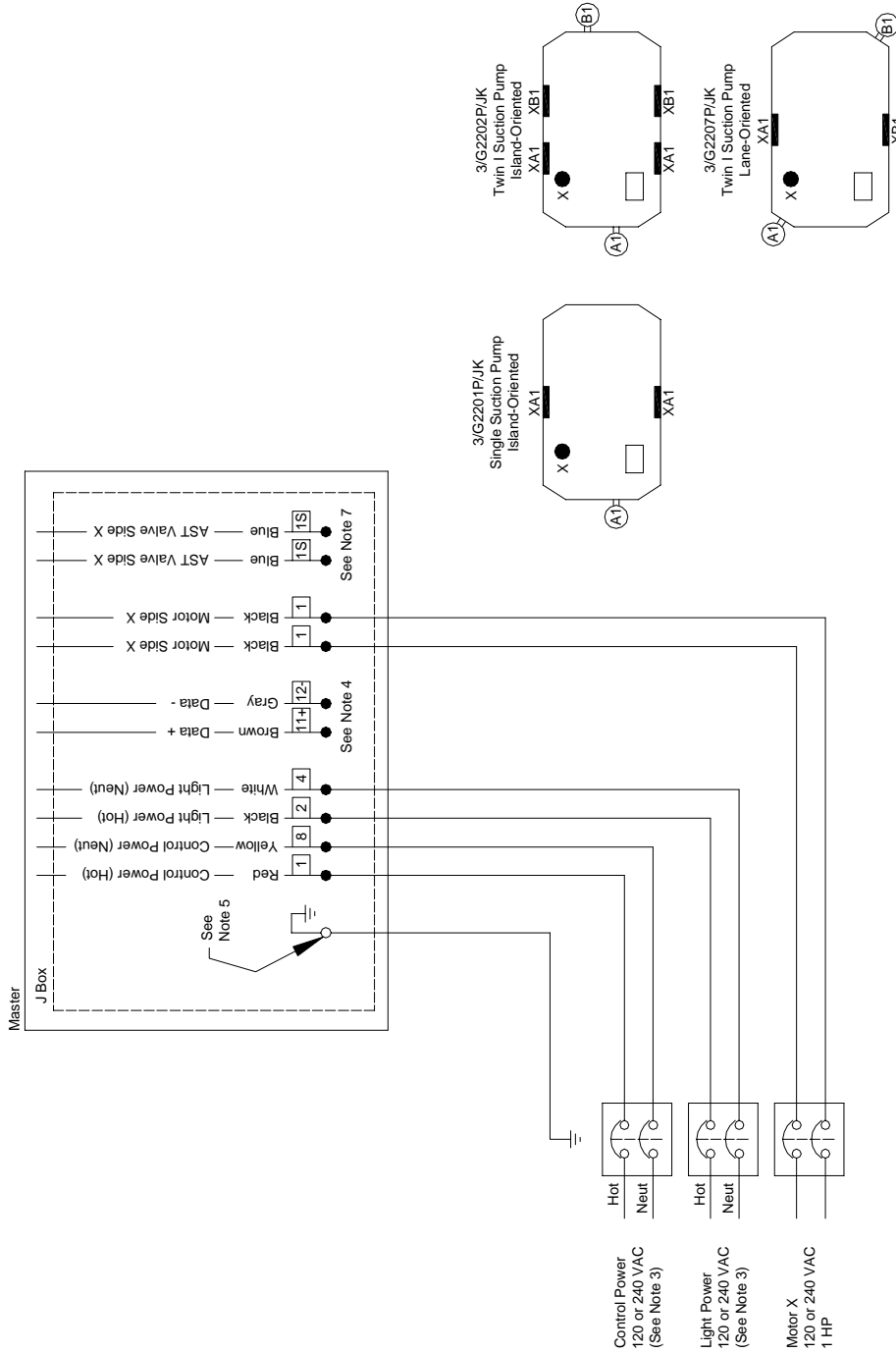

Notes:

1. All equipment to be installed in accordance with all applicable local, state, and federal codes, including, but not limited to, the National Electrical Code (NFPA 70), NFPA 30, and the Automotive and Marine Service Station Code (NFPA 30A).
2. For wiring connections, use wires rated at least 90°C, 600V, Gas & Oil Resistant.
3. See wire size chart for proper gauge of the wires.
4. For full details of Wayne control systems interconnections see the manual provided with the Wayne pump control system or Wayne card processing system.
5. Attach all grounds to the ground screw provided.
6. Pump Motor can be wired for 240VAC to reduce current draw. All other wiring remains the same. Be sure to change the switch on the motor when running the motor at 240VAC.
7. If this dispenser is used with an aboveground tank, an anti-siphon valve mounted on top of the tank must be used. Two wires are provided to control a solenoid valve on top of the tank. The valve must be run at the same voltage as the motor. Only one dispenser inlet can be connected to an electric solenoid valve.

Wiring Diagram: 3/G2203P/JK Twin II Suction Pump (Island)

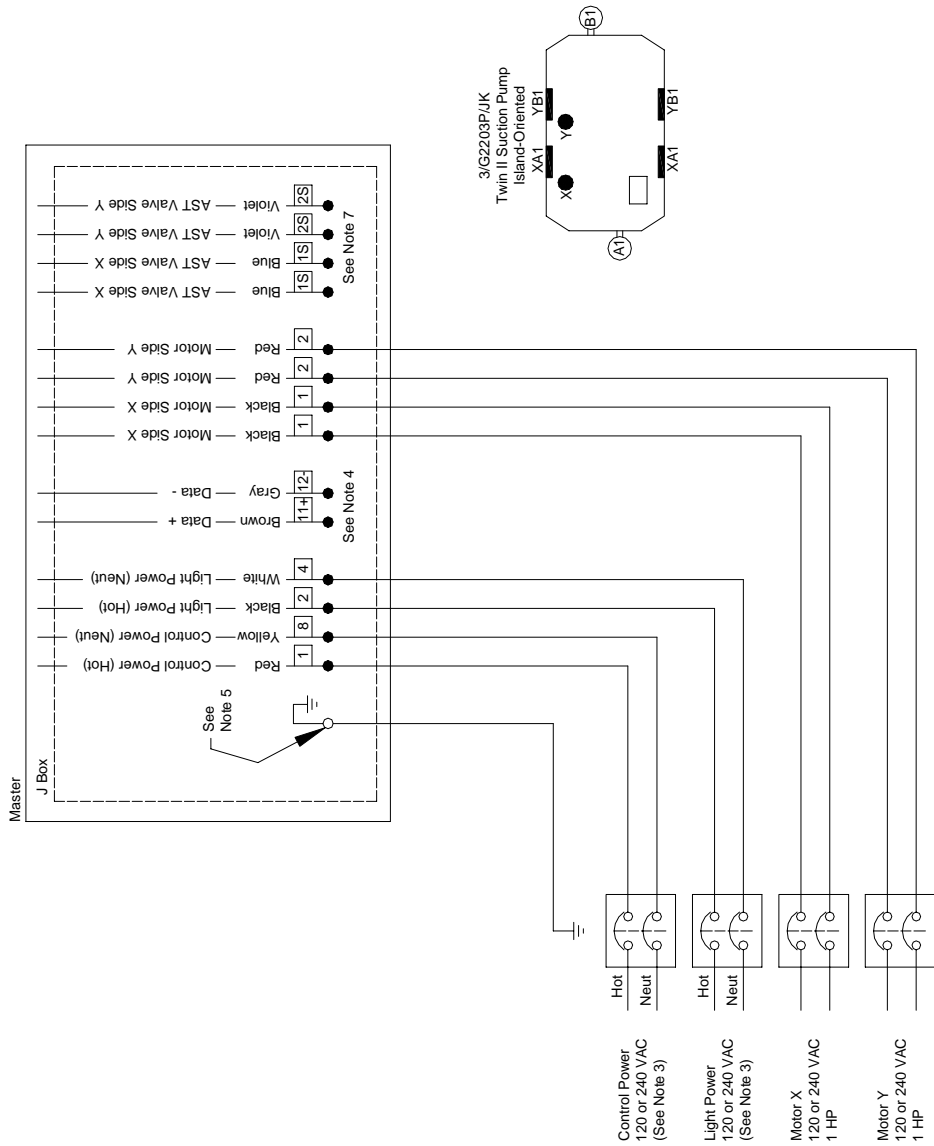

Notes:

1. All equipment to be installed in accordance with all applicable local, state, and federal codes, including, but not limited to, the National Electrical Code (NFPA 70), NFPA 30, and the Automotive and Marine Service Station Code (NFPA 30A).
2. For wiring connections, use wires rated at least 90°C, 600V, Gas & Oil Resistant.
3. See wire size chart for proper gauge of the wires.
4. For full details of Wayne control systems interconnections see the manual provided with the Wayne pump control system or Wayne card processing system.
5. Attach all grounds to the ground screw provided.
6. Pump Motor can be wired for 240VAC to reduce current draw. All other wiring remains the same. Be sure to change the switch on the motor when running the motor at 240VAC.
7. If this dispenser is used with an aboveground tank, an anti-siphon valve mounted on top of the tank must be used. Two wires are provided for each side to control a solenoid valve on top of the tank. The valve must be run at the same voltage as the motor. Only one dispenser inlet can be connected to an electric solenoid valve.

Wiring Diagram:

3/G2201D/GJK Single Remote (Island)

3/G2202D/GJK & 3/G2207D/GJK Twin I Remote (Island & Lane)

3/G2221D/GJK & 3/G2227D/GJKR Super High Cap. Single Rem. (Island & Lane)

3/G2227D/GJK Super High Capacity Twin I Remote (Lane)

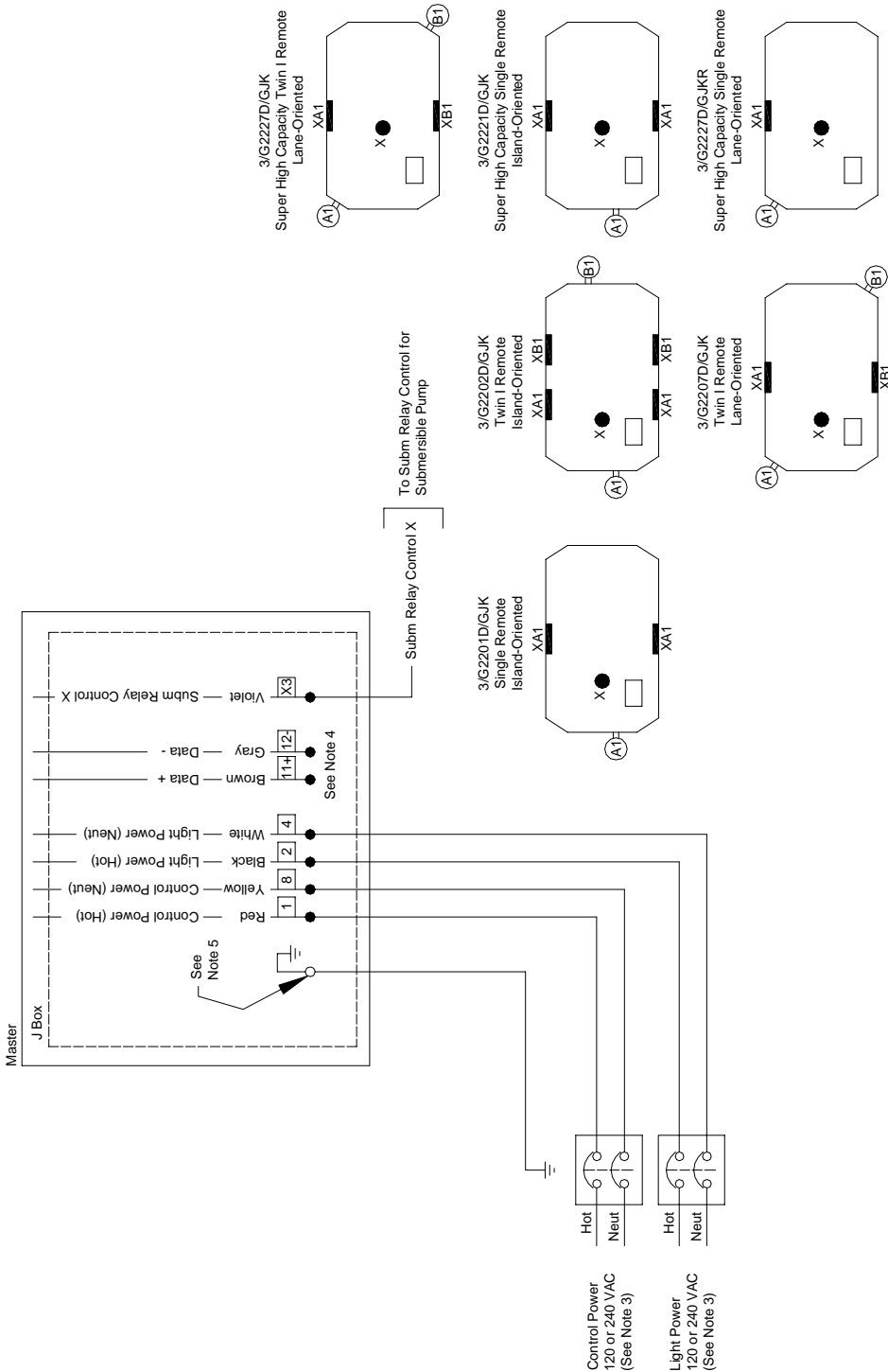

Notes:

1. All equipment to be installed in accordance with all applicable local, state, and federal codes, including, but not limited to, the National Electrical Code (NFPA 70), NFPA 30, and the Automotive and Marine Service Station Code (NFPA 30A).
2. For wiring connections, use wires rated at least 90°C, 600V, Gas & Oil Resistant.
3. See wire size chart for proper gauge of the wires.
4. For full details of Wayne control systems interconnections see the manual provided with the Wayne pump control system or Wayne card processing system.
5. Attach all grounds to the ground screw provided.
6. Remote dispensers require a relay to interface to the submersible pump motor.

Wiring Diagram: 3/G2203D/GJK Twin II Remote (Island)

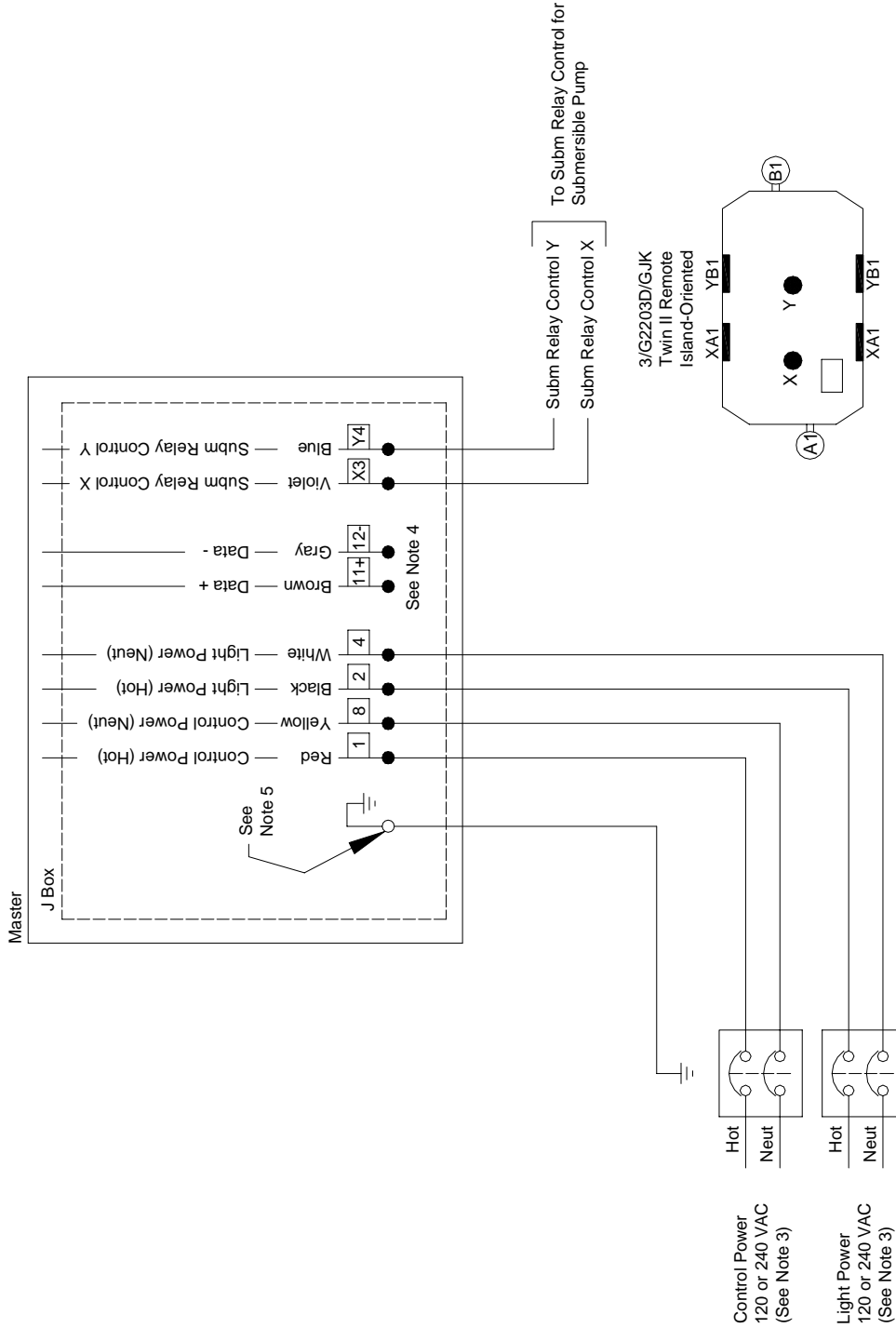

- Notes:
1. All equipment to be installed in accordance with all applicable local, state, and federal codes, including, but not limited to, the National Electrical Code (NFPA 70), NFPA 30, and the Automotive and Marine Service Station Code (NFPA 30A).
 2. For wiring connections, use wires rated at least 90°C, 600V, Gas & Oil Resistant.
 3. See wire size chart for proper gauge of the wires.
 4. For full details of Wayne control systems interconnections see the manual provided with the Wayne pump control system or Wayne card processing system.
 5. Attach all grounds to the ground screw provided.
 6. Remote dispensers require a relay to interface to the submersible pump motor.

Wiring Diagram: 3/G2227D/GJKMR Super High Capacity Single Master Remote (Lane)

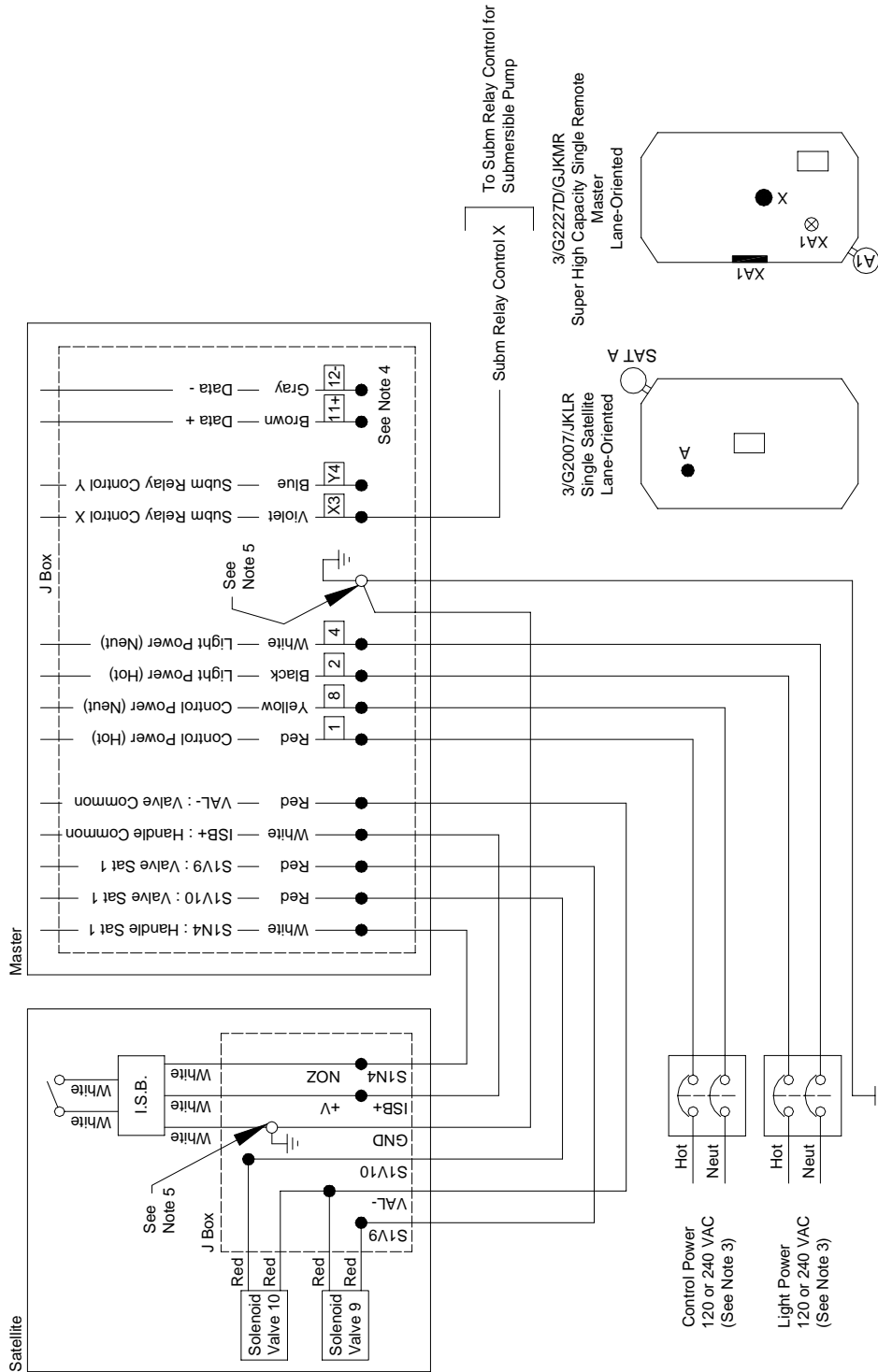

- Notes:
1. All equipment to be installed in accordance with all applicable local, state, and federal codes, including, but not limited to, the National Electrical Code (NFPA 70), NFPA 30, and the Automotive and Marine Service Station Code (NFPA 30A).
 2. For wiring connections, use wires rated at least 90°C, 600V, Gas & Oil Resistant.
 3. See wire size chart for proper gauge of the wires.
 4. For full details of Wayne control systems interconnections see the manual provided with the Wayne pump control system or Wayne card processing system.
 5. Attach all grounds to the ground screw provided.
 6. Remote dispensers require a relay to interface to the submersible pump motor.
 7. When used with a satellite, a Wayne Super High Capacity Satellite must be used.

Wiring Diagram: 3/G2227D/GJKM Super High Capacity Twin I Master Remote (Lane)

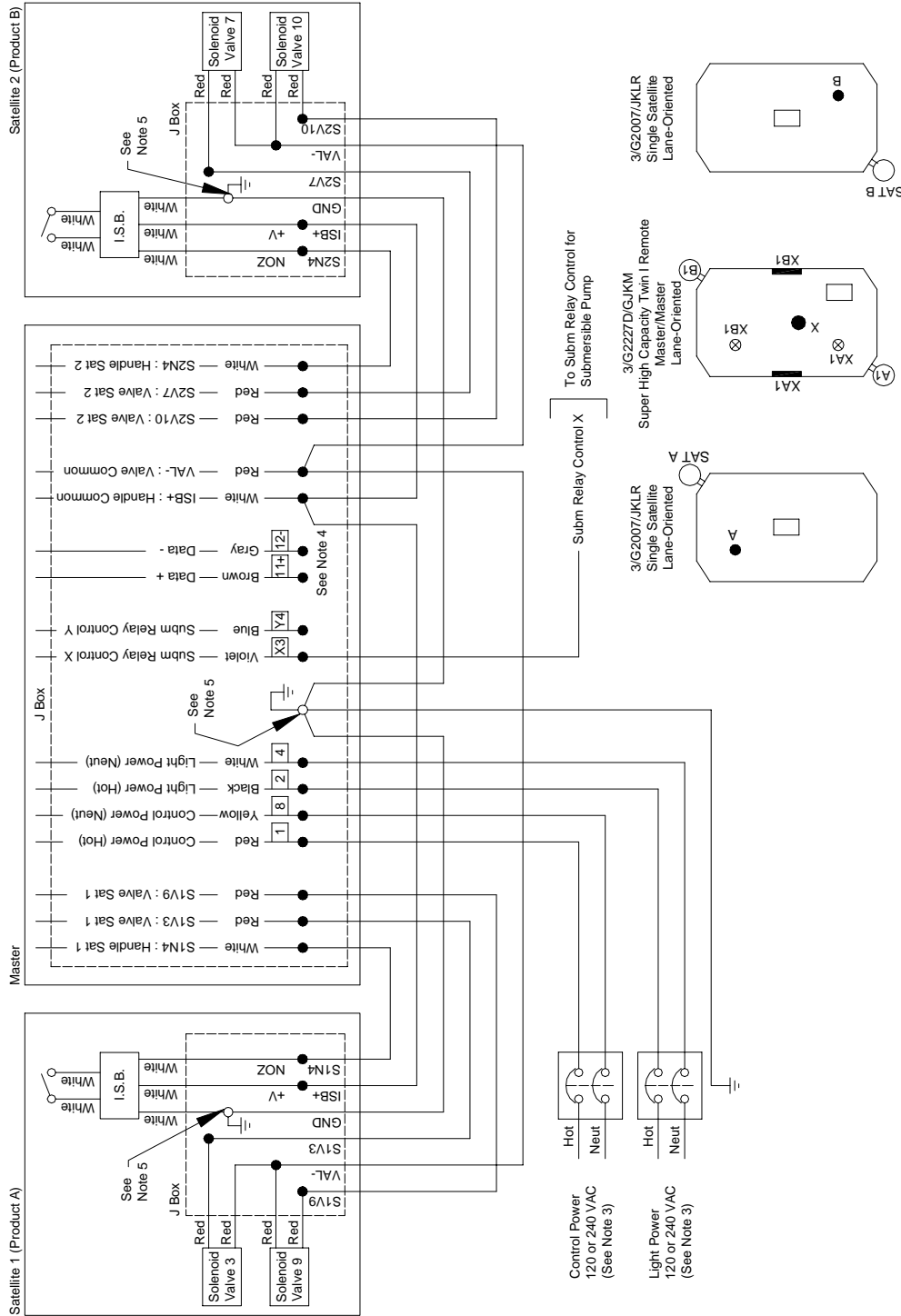

Notes:

1. All equipment to be installed in accordance with all applicable local, state, and federal codes, including, but not limited to, the National Electrical Code (NFPA 70), NFPA 30, and the Automotive and Marine Service Station Code (NFPA 30A).
2. For wiring connections, use wires rated at least 90°C, 600V, Gas & Oil Resistant.
3. See wire size chart for proper gauge of the wires.
4. For full details of Wayne control systems interconnections see the manual provided with the Wayne pump control system or Wayne card processing system.
5. Attach all grounds to the ground screw provided.
6. Remote dispensers require a relay to interface to the submersible pump motor.
7. When used with a satellite, a Wayne Super High Capacity Satellite must be used.

Wiring Diagram: 3/G2228D/GJKLM Super High Capacity Single Master Remote Dispenser & Satellite Combination (Lane)

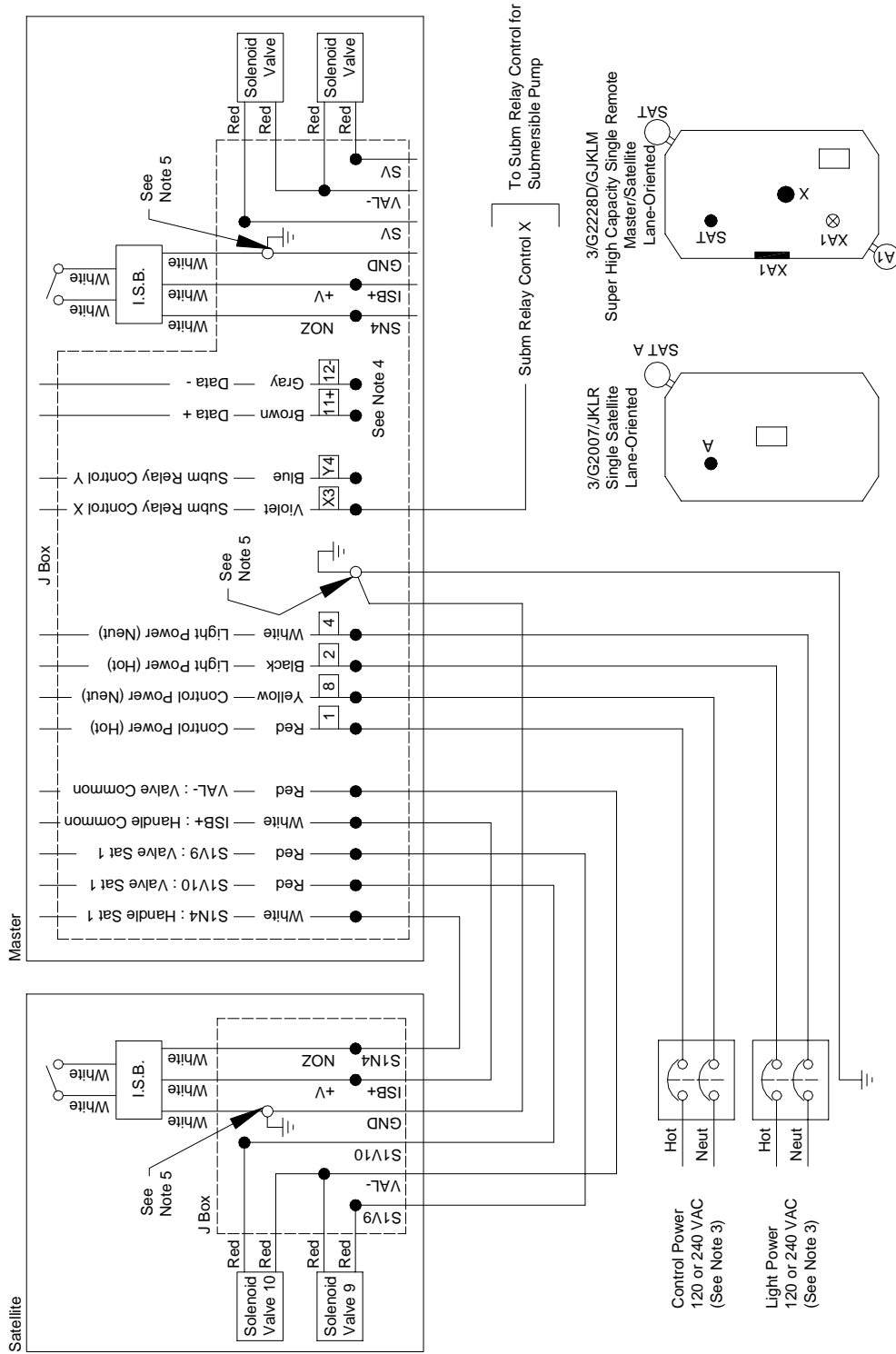

- Notes:**
1. All equipment to be installed in accordance with all applicable local, state, and federal codes, including, but not limited to, the National Electrical Code (NFPA 70), NFPA 30, and the Automotive and Marine Service Station Code (NFPA 30A).
 2. For wiring connections, use wires rated at least 90°C, 600V, Gas & Oil Resistant.
 3. See wire size chart for proper gauge of the wires.
 4. For full details of Wayne control systems interconnections see the manual provided with the Wayne pump control system or Wayne card processing system.
 5. Attach all grounds to the ground screw provided.
 6. Remote dispensers require a relay to interface to the submersible pump motor.
 7. When used with a satellite, a Wayne Super High Capacity Satellite must be used.

Wiring Diagram: 3/G2231D/GJK & 3/G2237D/GJKMR UHC Single Remote (Island & Lane)

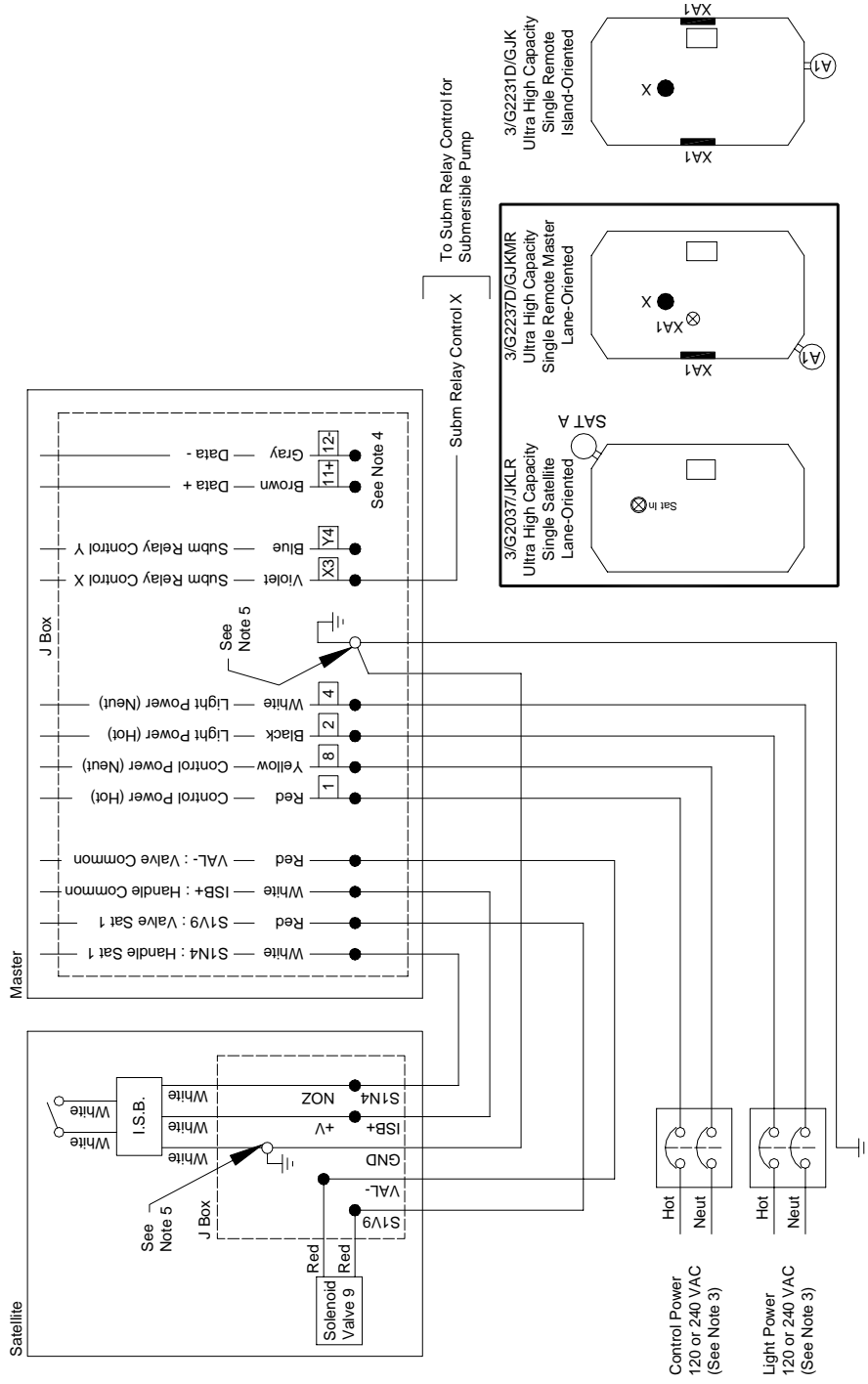

- Notes:
1. All equipment to be installed in accordance with all applicable local, state, and federal codes, including, but not limited to, the National Electrical Code (NFPA 70), NFPA 30, and the Automotive and Marine Service Station Code (NFPA 30A).
 2. For wiring connections, use wires rated at least 90°C, 600V, Gas & Oil Resistant.
 3. See wire size chart for proper gauge of the wires.
 4. For full details of Wayne control systems interconnections see the manual provided with the Wayne pump control system or Wayne card processing system.
 5. Attach all grounds to the ground screw provided.
 6. Remote dispensers require a relay to interface to the submersible pump motor.
 7. When used with a satellite, a Wayne Ultra High Capacity Satellite must be used.

Wiring Diagram:
3/G2232D/GJK & 3/G2237D/GJKM UHC Twin I Disp. (Island & Master Lane)
3/G2233D/GJK & 3/G2238D/GJKM UHC Twin II Disp. (Island & Master Lane)

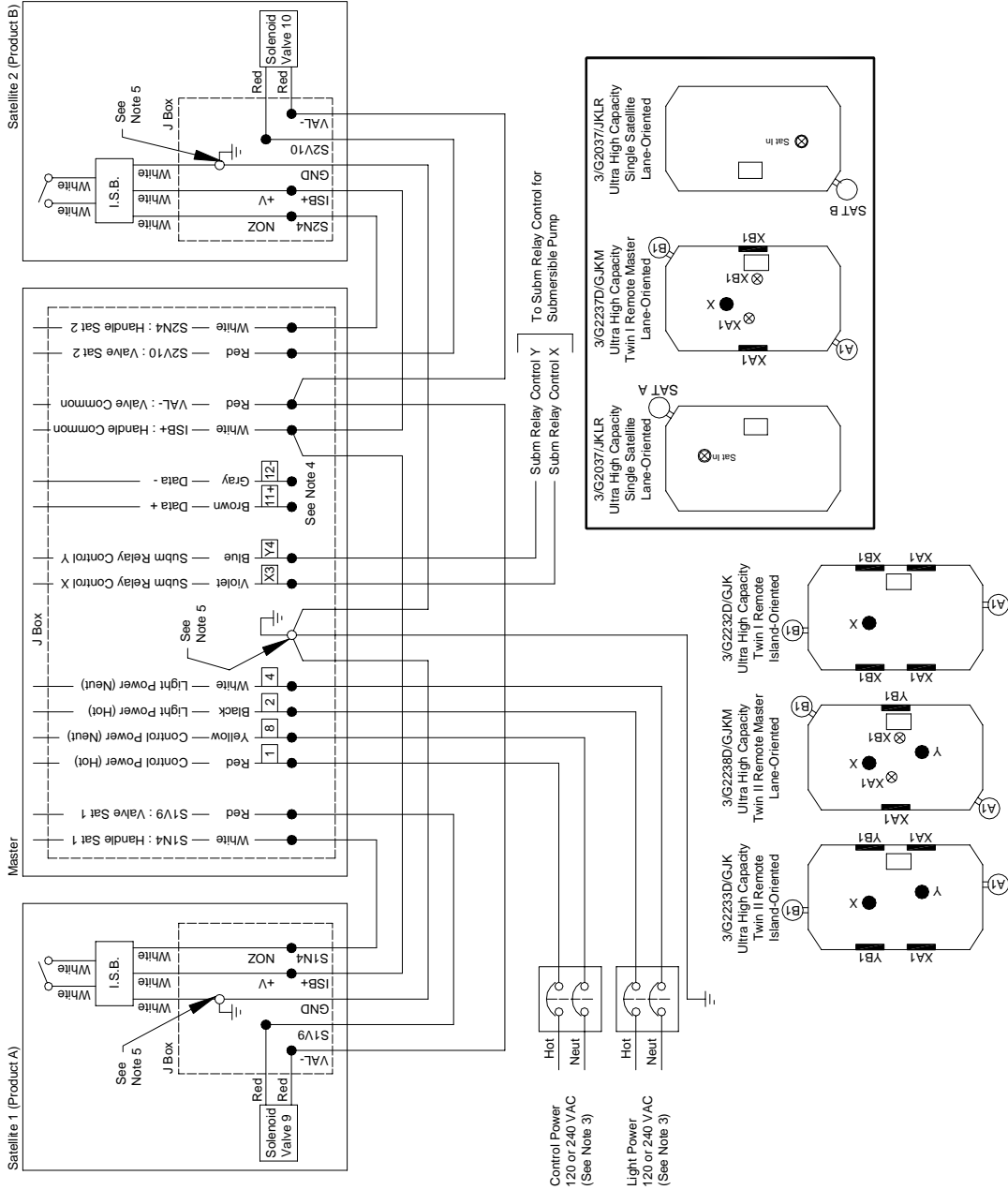

Notes:

1. All equipment to be installed in accordance with all applicable local, state, and federal codes, including, but not limited to, the National Electrical Code (NFPA 70), NFPA 30, and the Automotive and Marine Service Station Code (NFPA 30A).
2. For wiring connections, use wires rated at least 90°C, 600V, Gas & Oil Resistant.
3. See wire size chart for proper gauge of the wires.
4. For full details of Wayne control systems interconnections see the manual provided with the Wayne pump control system or Wayne card processing system.
5. Attach all grounds to the ground screw provided.
6. Remote dispensers require a relay to interface to the submersible pump motor.
7. When used with a satellite, a Wayne Ultra High Capacity Satellite must be used.

Wiring Diagram: 3/G2239D/GJKMR UHC Twin II Master Disp., Single-Sided (Lane)

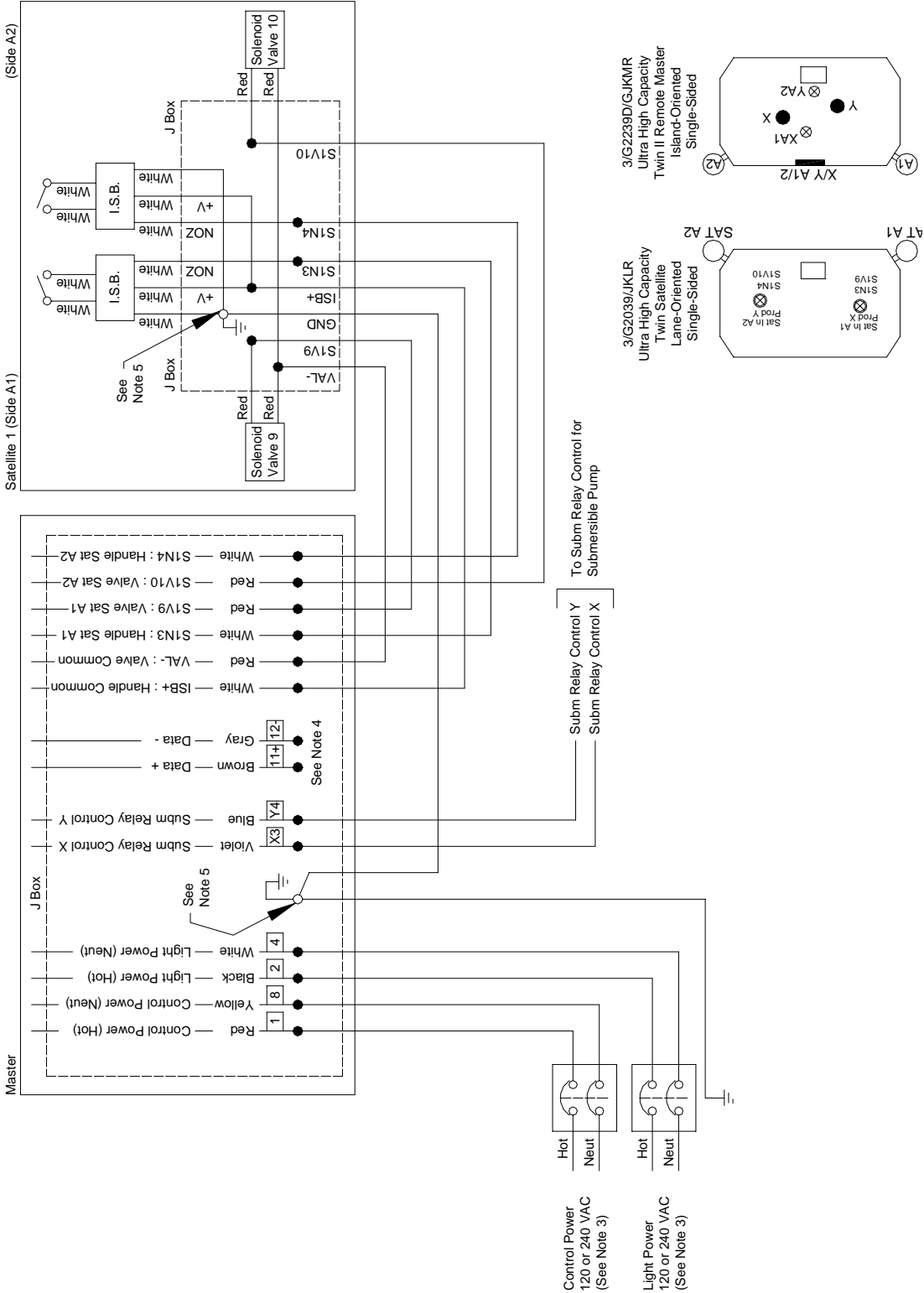

- Notes:**
1. All equipment to be installed in accordance with all applicable local, state, and federal codes, including, but not limited to, the National Electrical Code (NFPA 70), NFPA 30, and the Automotive and Marine Service Station Code (NFPA 30A).
 2. For wiring connections, use wires rated at least 90°C, 600V, Gas & Oil Resistant.
 3. See wire size chart for proper gauge of the wires.
 4. For full details of Wayne control systems interconnections see the manual provided with the Wayne pump control system or Wayne card processing system.
 5. Attach all grounds to the ground screw provided.
 6. Remote dispensers require a relay to interface to the submersible pump motor.
 7. When used with a satellite, a Wayne Ultra High Capacity Satellite must be used.

Wiring Diagram: 3/G2238D/GJKLM UHC Single Master Dispenser & Satellite Combination (Lane)

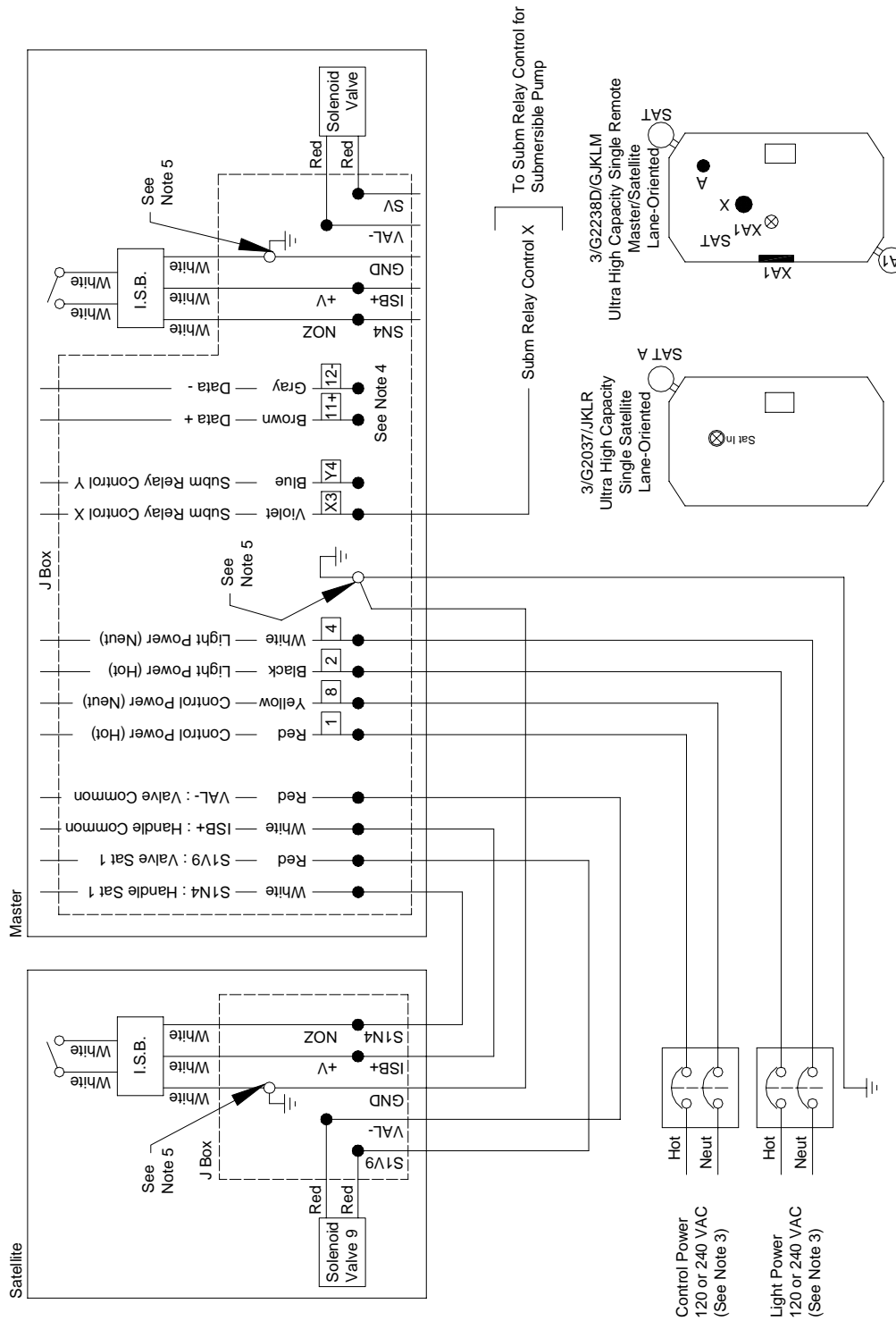

- Notes:**
1. All equipment to be installed in accordance with all applicable local, state, and federal codes, including, but not limited to, the National Electrical Code (NFPA 70), NFPA 30, and the Automotive and Marine Service Station Code (NFPA 30A).
 2. For wiring connections, use wires rated at least 90°C, 600V, Gas & Oil Resistant.
 3. See wire size chart for proper gauge of the wires.
 4. For full details of Wayne control systems interconnections see the manual provided with the Wayne pump control system or Wayne card processing system.
 5. Attach all grounds to the ground screw provided.
 6. Remote dispensers require a relay to interface to the submersible pump motor.
 7. When used with a satellite, a Wayne Ultra High Capacity Satellite must be used.

Appendix C

Dispenser Software Configuration, Statistics, & Diagnostics

C.1 General

- The Century Series has a sophisticated electronic platform that offers a variety of controls, error monitoring, and diagnostics. The main section of the manual only includes the few necessary configuration changes to make the dispenser operational. It also covers retrieving the basic statistical information – volume totals. This appendix lists all of the controls, statistics, and diagnostics, and provides general instructions on how to navigate the software and make changes.
- The dispenser software configuration defines how the dispenser operates, what features are available, display formats, etc. The configuration is divided into Functions (F “xx”) and sub-functions (xx.xx). For example, the Clock Configuration function (F02) contains the sub-functions for the time (2.00), date (2.01), and year (2.02). The configuration settings are pre-loaded at the factory based upon the model and options.
- The dispenser software also includes statistical information – totalizers, counters, and diagnostic information. Statistical information is divided into Statistics (S “xx”) and sub-statistics (xx.xx). For example, the Power Cycle statistic (S25) includes the sub-statistics for the number of power cycles (25.00), number of software resets (25.01), and the number of cold start power cycles (25.02). Depending on the statistic, it may be non-resettable, resettable, or include the last “x” number of items.
- Functions and statistics are accessed using the infrared remote control (IRC). Access requires a password. See Section 5.4.2 for the password access information.
- The following sections provide instructions on the basic operational procedures – entering and exiting functions & statistics, IRC commands, changing sub-function values, etc. At the end of this appendix, is a complete list of functions and statistics.

C.2 Entering Functions and Statistics

Entering Functions & Statistics				
Step	IRC Command	Sale \$ Display	Volume Display	Unit Price Display
1 Enter sign on	Press either <ENTER>, <1>, or <2> depending upon access level (See Section 5.4.2)	PASS 1	[blank]	[blank]
2 Enter password	Type the corresponding password & Press <ENTER>	PASS 2	[blank]	[blank]
3 Re-enter password	Type the password again & Press <ENTER>	[software version]	[software date]	F - -

- You are now at the function level (F - - on Status display). Reference Section C.3, IRC Commands, on how to navigate the functions. If you wish to enter Statistics mode, press the <Down> key.

C.3 IRC Commands

Results of IRC Commands at Different Operating States			
IRC Keys	Function Level F - - on Unit Price Display	Function Level F "xx" on Unit Price Display	Sub-function Level xx.xx on Unit Price Display
NEXT	F00	Next higher function #	Next higher sub-function # (cycles back to lowest at highest)
UP	S - - (Statistics Mode)	Next higher function #	Next higher sub-function # (cycles back to lowest after highest)
DOWN	S - - (Statistics Mode)	Next lower function #	Next lower sub-function # (cycles back to highest after lowest)
ENTER	Pressing 3 times will exit configuration mode without saving	Sub-function level (xx.xx)	Back to function level (except after entering new value, it displays the change)
CLEAR	N/A	F - -	Back to function level (except while entering new value can be used to erase last digit typed)
#	N/A	N/A	Clears Gallons/Liters display so new value can be entered
Digits	After pressing <ENTER> will take you to the Function level of the digits entered	After pressing <ENTER> will take you to the Function level of the digits entered	If you do not clear the display with the "#" key first, after pressing <ENTER> it will take you to the sub-function level of the digits entered. If you clear the display, it will change the value of the sub-function to the digits entered after pressing <ENTER>.

Note: When in Statistics Mode (S - - or S "xx" on Unit Price display), the above commands work the same way. When at S - -, the <UP> or <DOWN> keys take you to F - -.

C.4 Changing Subfunction Values

- To change the operating characteristics of the dispenser, you need to go to the sub-function level in the configuration. The following table shows the steps for changing any sub-function value. Changing the date (sub-function 2.01) is used as an example in the table below to help explain the steps. The date values are shown in parentheses in the IRC Command column. The steps assume that you are at the point where you just signed on with your password or at any function level (F - - or F “xx” show in the Unit Price display).

Changing Sub-function Values (Example: Changing the date)				
Step	IRC Command	Sale \$ Display	Volume Display	Unit Price Display
1 Go to the function level of the desired sub-function	Type the function number (e.g. 2) and then press <ENTER>	-----	[blank]	F 02
2 Go to the sub-function level	Press <ENTER>	-----	[time in HH.MM]	2.00
3 Go to the desired sub-function	Use the up, next, or down keys to scroll to the desired sub-function. Or, type the digits of the sub-function number (e.g. 1) and then press <ENTER>	-----	[date in MM.DD]	2.01
4 Clear the sub-function value	Press “#”	[blank]	[date in MM.DD]	2.01
5 Change the sub-function to the desired value	Type the digits of the desired change (e.g. 1124 for Nov 24) and then press <ENTER>	-----	[entered date in MM.DD]	2.01
6 Return to function level	Press <ENTER>	-----	[blank]	F 02

C.5 Resetting Totals

- Statistics listed as “totals” may be reset to zero at any time.
- You must exit using the “exit and save” feature for the reset to take place.

Resetting Totals (from sub-statistic level)				
Step	IRC Command	Sale \$ Display	Volume Display	Unit Price Display
1 Clear total	Press <#>	CLEAR	totALS	xx.xx
2 Confirm clear	Press <ENTER>	PASS	[clear]	xx.xx
3 Enter reset password	Type <42> & Press <ENTER>	-----	[blank]	S xx

C.6 Exiting Functions

Exiting Functions (from function level: F - - or F “xx” in Status display)				
Step	IRC Command	Sale \$ Display	Volume Display	Unit Price Display
1 Go to exit function	Type <0> & then Press <ENTER>	-----	[blank]	F 00
2 Go to exit sub-function	Press <ENTER>	-----	1	0.00
3 Clear display	Press“#”	[blank]	1	0.00
4 Enter exit choice	Type the value of the exit choice below & then press <ENTER> (example shown is 3, exit and save) 1 = Do not exit & do not save changes 2 = Exit & do not save changes 3 = Exit & save changes	-----	3	0.00
5 Exit configuration	Press <ENTER>	CHAnGE	StorEd	[price]

C.7 Exiting Statistics

Exiting Statistics (from statistics level: S- - or S “xx” in Status display)				
Step	IRC Command	Sale \$ Display	Volume Display	Unit Price Display
1 Go to statistics entry point	Press <CLEAR> Note: if you are not resetting the totals, press <ENTER> 3 times to exit statistics	[side A transaction count]	[side B transaction count]	S - -
2 Go to function level	Press <UP>	[software version]	[software date]	F - -
3 Go to exit function	Type <0> & Press <ENTER>	-----	[blank]	F 00
4 Go to exit sub-function	Press <ENTER> again	-----	1	0.00
5 Clear display	Press“#”	[blank]	1	0.00
6 Exit and save changes	Type <3> & then press <ENTER>	-----	3	0.00
7 Exit configuration	Press <ENTER> again	CHAnGE	StorEd	[price]

C.8 Quick Exit from Functions or Statistics

- If you do not wish to save any changes, you may use the “Quick Exit” feature.

Quick Exit from Functions or Statistics w/o Saving (F “xx” or S “xx” on Status display)				
Step	IRC Command	Sale \$ Display	Volume Display	Unit Price Display
1 Go to statistics or function level entry point	Press <CLEAR> In Statistics, you will go to S --. In Functions, you will go to F --.	[If S --, Side A transaction count if F --, Software revision]	[If S --, Side B transaction count if F --, Software date]	S -- or F --
2 Exit statistics or functions	Press <ENTER> three times	[last transaction \$ value]	[last transaction volume]	[price]

C.9 Dispenser Side & Nozzle Identification

- In order to configure the dispenser correctly or understand the totalizer assignments, you need to understand how the dispenser sides and nozzles are identified in the software. UHC models are slightly different concerning the Junction Box and Inlet positions, but the same principles apply.
- The base layouts in Appendix A contain a Base Orientation drawing which show how the sides and nozzles are identified for each model.
- Figure C-1 explains how to interpret the Base Orientation drawings. Use the main junction box to determine the physical orientation of the dispenser. Note on UHC dispensers, the j-box is centered. Dispensers with the pulse output interface option have a second junction box on the opposite side for the pulse output interface wire terminations. The main junction box has a 3/4” conduit and the pulse output junction box has a 1/2” conduit.

Figure C-1 Base Orientation Drawings

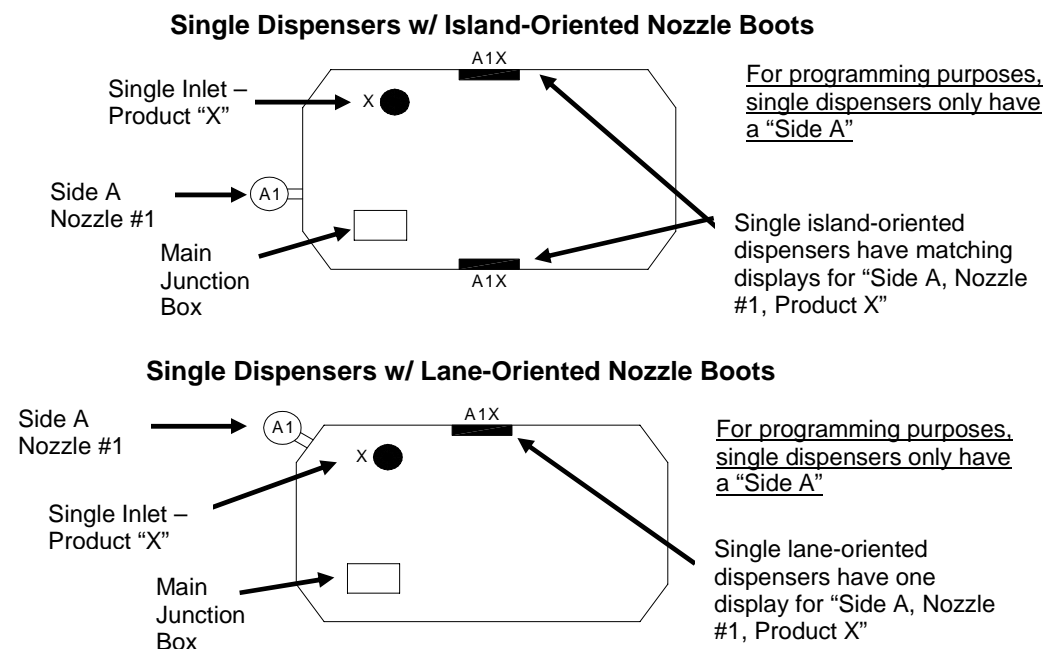

Twin Dispensers w/ Island-Oriented Nozzle Boots

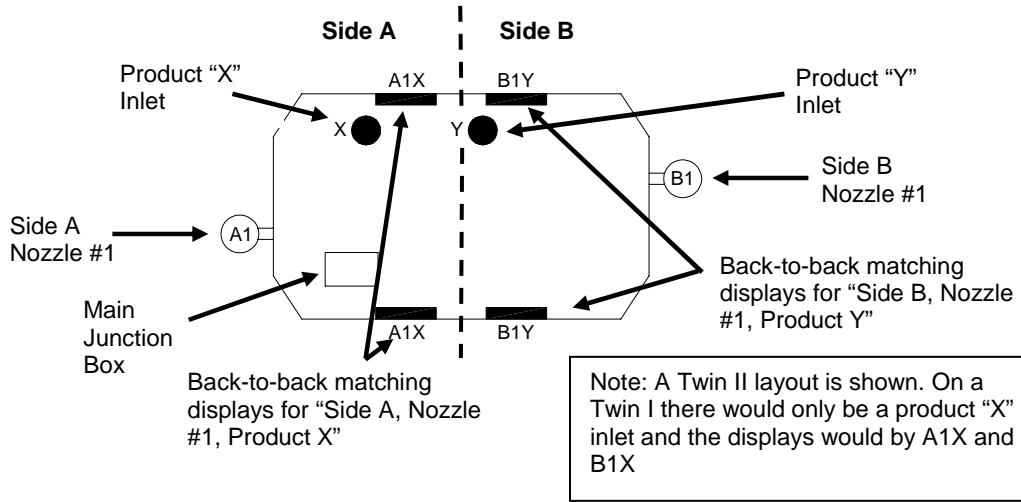

Twin Dispensers w/ Lane-Oriented Nozzle Boots

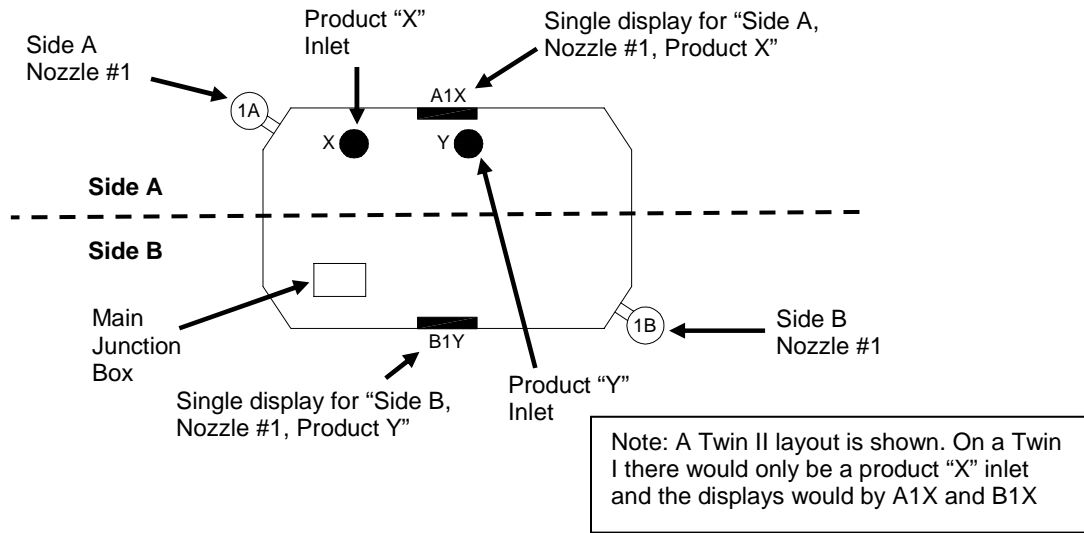

Single-Sided Twin Dispensers w/ Lane-Oriented Nozzle Boots

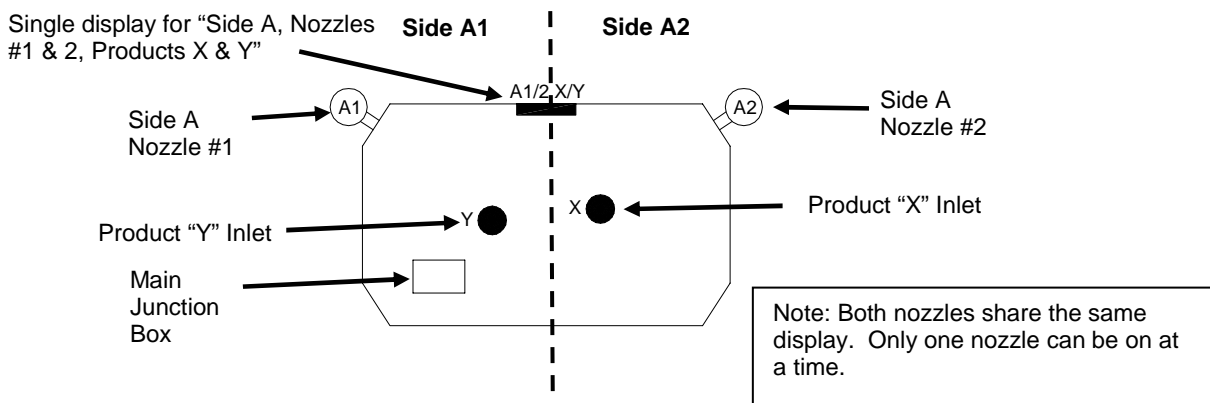

C.10 List of Statistics

- Following is a complete list of statistics and diagnostics available in the Century Series. Statistics identified as “Side B” only apply to twin units with two hoses.
- Statistics identified as “Totals” are resettable and statistics identified as “Totalizers” are non-resettable.

Statistic No.	Statistic Name	Sub-Statistic No.	Sub-Statistic Description
S - -	Statistics Entry Point	N/A	Transaction count for Side A & Side B (alternates)
S 01	Side A Totals (For 3/G2239 use 1.12 for Nozzle 2 Volume Totals, 1.22 for Nozzle 2 Money Totals, etc.)	1.11	Volume total
		1.21	Money Total
		1.31	Credit Total
		1.41	Cash Total
		1.51	Serial filling mode filling count (Wayne protocol)
		1.61	Stand alone mode filling count (standalone or pulse output)
S 02	Side B Totals	2.11	Volume total
		2.21	Total Money Total
		2.31	Credit Total
		2.41	Cash Total
		2.51	Serial filling mode filling count (Wayne protocol)
		2.61	Stand alone mode filling count (standalone or pulse output)
S 03	Side A Error/Event Counter Totals	3.1 - 3.99	Sub-statistic = error/event code (1 – 99) with counter value 0-255
S 04	Side B Error/Event Counter Totals	4.1 - 4.99	Sub-statistic = error/event code (1 – 99) with counter value 0-255
S 05	Side A Meter Volume Totals	5.M0	Meter volume totals (M = meter #. Use the NEXT key to scroll through sub-functions to the meter number(s) for your desired model or reference the functions list for meter assignments. SHC models have two meters per hose.) Note: See Meter Number Assignments table at the end of this section to determine the meter numbering for your model.
S 06	Side B Meter Volume Totals	5.M0	Meter volume totals (M = meter #. Use the NEXT key to scroll through sub-functions to the meter number(s) for your desired model or reference the functions list for meter assignments. SHC models have two meters per hose.) Note: See Meter Number Assignments table at the end of this section to determine the meter numbering for your model.

Statistic No.	Statistic Name	Sub-Statistic No.	Sub-Statistic Description
S 11	Side A Totalizers (For 3/G2239 use 1.12 for Nozzle 2 Volume Totals, 1.22 for Nozzle 2 Money Totals, etc.)	11.11	Volume totalizer
		11.21	Total Money totalizer
		11.31	Credit totalizer
		11.41	Cash totalizer
		11.51	Serial filling mode filling count (Wayne protocol)
		11.61	Stand alone mode filling count (standalone or pulse output)
S 12	Side B Totalizers	12.11	Volume totalizer
		12.21	Total Money totalizer
		12.31	Credit totalizer
		12.41	Cash totalizer
		12.51	Serial filling mode filling count (Wayne protocol)
		12.61	Stand alone mode filling count (standalone or pulse output)
S 13	Side A Error/Event Counter Totalizers	13.00- 13.99	Sub-statistic = error/event code (1 – 99). Maintains counter 0-999.
S 14	Side B Error/Event Counter Totalizers	14.00- 14.99	Sub-statistic = error/event code (1 – 99). Maintains counter 0-999.
S 15	Side A Meter Volume Totalizers	15.M0	Meter volume totalizer (M = meter #. Use the NEXT key to scroll through sub-functions to the meter number(s) for your desired model or reference the functions list for meter assignments. SHC models have two meters per hose.) Note: See Meter Number Assignments table at the end of this section to determine the meter numbering for your model.
S 16	Side B Meter Volume Totalizers	16.M0	Meter volume totalizer (M = meter #. Use the NEXT key to scroll through sub-functions to the meter number(s) for your desired model or reference the functions list for meter assignments. SHC models have two meters per hose.) Note: See Meter Number Assignments table at the end of this section to determine the meter numbering for your model.
S 17	Side A WIP (Pulser) Volume Totalizers	17.M0	WIP volume totalizer (M = meter #. Use the NEXT key to scroll through sub-functions to the meter number(s) for your desired model or reference the functions list for meter assignments. SHC models have two meters per hose.) Note: See Meter Number Assignments table at the end of this section to determine the meter numbering for your model.

Statistic No.	Statistic Name	Sub-Statistic No.	Sub-Statistic Description
S 18	Side B WIP (Pulser) Volume Totalizers	18.M0	WIP volume totalizer (M = meter #. Use the NEXT key to scroll through sub-functions to the meter number(s) for your desired model or reference the functions list for meter assignments. SHC models have two meters per hose.) Note: See Meter Number Assignments table at the end of this section to determine the meter numbering for your model.
S 21	Side A Error/Event Log	21.01 – 21.50	Sub-statistic = error/event record (range 01 - 50 w/ 01 being most recent error code or event). Alternates event time (HH.MM) & data (CC.DD.NN) (CC = error code DD = device # NN = nozzle number) Press <ENTER> Alternates event date (MM.DD.YY) & filling count
S 22	Side B Error/Event Log	22.01 – 22.50	Sub-statistic = error/event record (range 01 - 50 w/ 01 being most recent error code or event). Alternates event time (HH.MM) & data (CC.DD.NN) (CC = error code DD = device # NN = nozzle number) Press <ENTER> Alternates event date (MM.DD.YY) & filling count
S 23	Side A Transaction History Log	23.01 – 23.10	Sub-statistic = transaction record (range 01 – 10 w/ 01 being the most recent transaction). Provides transaction volume.
S 24	Side B Transaction History Log	24.01 – 24.10	Sub-statistic = transaction record (range 01 – 10 w/ 01 being the most recent transaction). Provides transaction volume.
S 25	Total Number of Power Cycles	25.00	Number of power cycles
		25.01	Number of software resets
		25.02	Number of cold start power cycles
S 26	Reset History	26.01 - 26.50	Sub-statistic = reset event record (range 01 – 50 w/ 01 being the most recent reset event). Alternates event time (HH.MM) & data (TT.FFFF) (TT = trap id FFFF = value of the trap flag register) Press <ENTER> Alternates event date (MM.DD.YY) & return address (SS.OOOO) (SS = hex code segment OOOO = hex code offset into segment)

C.11 Meter Number Assignments

*Note: Super High Capacity models have two iMeters connected to one discharge to provide increased performance.

Model	3/G2201/ 3/G2231/ 3/G2237/MR 3/G2238/LM	3/G2202/ 3/G2203/ 3/G2207/ 3/G2232/ 3/G2233/ 3/G2237/M 3/G2238/M	3/G2221/ 3/G2227/R 3/G2227/MR 3/G2228/LM	3/G2227/ 3/G2227/M	3/G2239/MR
SIDE A					
Meter 1	1	1	1	1	1
Meter 2	N/A	N/A	5	2	5 ¹
SIDE B					
Meter 1	N/A	5	N/A	5	
Meter 2	N/A	N/A	N/A	6	

¹Note: The 3/G2239/MR has 2 hoses on the same side even though it is a Twin II.

C.12 Generic Configuration Functions

- Following is a complete list of configuration functions and sub-functions that covers most models. The Configuration Setting column shows the default settings loaded at the factory. Note some settings differ if the pulse output interface option is ordered. Any settings which differ based on the model are referenced to model tables found later in this section.

Function Number & Name		Sub-function Number & Description		Configuration Setting
F - -	Function Level	N/A	Alternates software revision number and date	
F00	Exit Function	.00	1 = Do not exit and do not save changes 2 = Exit, but do not save changes 3 = Exit and save changes	
F01	Filling Modes	.00	1 = Serial mode, dispenser controlled by site controller serial link 2 = Stand Alone Mode, dispenser not supervised by a site controller w/ serial link (<u>used for standalone and pulse output interface</u>) 3 = Serial W&M Mode, same as #1 but vol decimal point format forced to .xxx vol units 4 = Stand Alone W&M Mode, same as #2 but vol decimal point format forced to .xxx vol units	1
F02	Clock Configuration	.00	Time in the format HH.MM	
		.01	Date in the format MM.DD	

Function Number & Name		Sub-function Number & Description		Configuration Setting
		.02	Year in the format YYYY	
F03	Set Side A Unit Prices	.01	Set credit price	0
		.11	Set cash price	0
F04	Set Side B Unit Prices	.01	Set credit price	0
		.11	Set cash price	0
F05	Set Side A Fueling Point Address	.00	Fueling point address, 0–98, where 0=none assigned	0
F06	Set Side B Fueling Point Address	.00	Fueling point address, 0–98, where 0=none assigned	0
F07	Dispenser Configuration	.00	Max. logical nozzle number for each side, 1-8	1
		.01	Dispenser geometry, 1 = single-sided 2 = double-sided	see C.13, C.14 or C.15 by model
		.02	Max. blend error allowed, 1-5 (units of %)	1
		.03	First check set for blending if liters, 2-200 (units of 1/10 liters)	50
		.04	First check set for blending if gallons, 5-50 (units of 1/10 gallons)	12
		.05	Reserved	1
		.06	Manufacturing default for Intelligent Pulser	
		.07	Stop button configuration, 1 = stop both sides, 2 = stop side	2
F08	Side A Dispenser Type Configuration Part #1	.01	Physical nozzle number assignment, 0–8, 0 = none assigned	1
		.11	Product type assignment, 1 = non-blend, 2 = blend	1
		.21	Unit price display assignment, 0–8, 0 = none assigned	1
		.31	Primary meter number assignment, 0-8, 0 = none assigned	1
		.41	Secondary meter number assignment, 0-8, 0 = none assigned	see C.13, C.14 or C.15 by model
		.51	Primary valve number assignment, 0-8, 0 = none assigned	1
		.61	Primary valve type, 1–2, 1 = on/off, 2 = proportional, 3 = Two stage	2 (3 for UHC models)
		.71	Secondary valve number assignment, 0-8, 0 = none assigned	see C.13, C.14 or C.15 by model
		.81	Secondary valve type, 1–2, 1 = on/off, 2 = proportional, 3 = Two stage	2
F09	Side B Dispenser Type Configuration Part #1	.01	Physical nozzle number assignment, 0–8, 0 = none assigned	1
		.11	Product type assignment, 1 = non-blend, 2 = blend	1
		.21	Unit price display assignment, 0–8, 0 = none assigned	1
		.31	Primary meter number assignment, 0-8, 0 = none assigned	5
		.41	Secondary meter number assignment, 0-8, 0 = none assigned	see C.13, C.14 or C.15 by model
		.51	Primary valve number assignment, 0-8, 0 = none assigned	5

Function Number & Name		Sub-function Number & Description		Configuration Setting
		.61	Primary valve type, 1–2, 1 = on/off, 2 = proportional, 3 = Two stage	2 (3 for UHC models)
		.71	Secondary valve number assignment, 0-8, 0 = none assigned	see C.13, C.14 or C.15 by model
		.81	Secondary valve type, 1–2, 1 = on/off, 2 = proportional, 3 = Two stage	2
F10	Side A Dispenser Type Configuration Part #2	.01	Octane number assignment, 00-99, 00 = non assigned	0
		.11	Product select button input number assignment, 0-8, 0 = none assigned	0
		.21	Push-to-start button input number assignment, 0-8, 0 = none assigned	0
		.31	Vapor recovery system enabled, 0 = no, 1 = yes	0
		.41	Beep annunciator in a series of six beeps on physical nozzle lift, 1 = yes, 2 = no	2
F11	Side B Dispenser Type Configuration Part #2	.01	Octane number assignment, 00-99, 00 = non assigned	0
		.11	Product select button input number assignment, 0-8, 0 = none assigned	0
		.21	Push-to-start button input number assignment, 0-8, 0 = none assigned	0
		.31	Vapor recovery system enabled, 0 = no, 1 = yes	0
		.41	Beep annunciator in a series of six beeps on physical nozzle lift, 1 = yes, 2 = no	2
F12	Side A Pump Assignments	.01	Primary submersible pump relay assignment, 0-8, 0 = none assigned	1 (see C.15 for 3/G2239/MR assignments)
		.11	Secondary submersible pump relay assignment, 0-8, 0 = none assigned	0
F13	Side B Pump Assignments	.01	Primary submersible pump relay assignment, 0-8, 0 = none assigned	see C.13, C.14 or C.15 by model
		.11	Secondary submersible pump relay assignment, 0-8, 0 = none assigned	0
F14	Dispenser Display Configuration	.00	Number of unit price displays per side, 0-8, 0 = none supported	1
		.01	Display mode after sale paid 1 = money is actual, volume is actual, unit price is actual 2 = Money is zeros, volume is zeros, unit price is actual 3 = Money is zeros, volume is zeros, unit price is blanks 4 = Money and volume actual, unit price blank	1
		.02	Money display digits right of decimal point, 0-4	2
		.03	Volume display digits right of decimal point, 0-4	3
		.04	Unit price display digits right of decimal point, 0-4	3
		.05	Flash selected unit price display after 8s blanks 0s. 1 = no flash, 2 = flash until flow, 3 = flash always	2

Function Number & Name		Sub-function Number & Description		Configuration Setting
		.06	Suppress display of leading zeros in normal mode, 1 = yes, 2 = no	1
		.07	Totals and totalizers amount display digits right of the decimal point, 0-4	2
		.08	Totals and totalizers volume display digits right of the decimal point, 0-4	3
		.09	Display functionality 0 = Normal sale display 1 = Fleet sale display	0
F15	Dispenser Annunciator Configuration	.00	Beep annunciator on any button push 1 = yes 2 = no	1
		.01	Beep annunciator on physical nozzle lift 1 = yes, 2 = no	1
		.02	Repeat annunciator beep if physical nozzle is out and push-to-start or grade select is not satisfied 1 = yes, 2 = no	1
		.03	Beep annunciator once for each eights, blanks, and zeros 1 = yes, 2 = no	1
F16	Pulser Configuration	.00	Measurement mode 1 = liters, 2 = gallons, 3 = imperial gallons	2
		.01	Pulser reverse pulse hysteresis, 1=64	10
		.02	Reserved	
		.03	Reverse pulse limit (after hysteresis) on an idle/unused pulser, 1-255	80
		.04	Meter type 1 = WIP, 2 = PPM w/ LC meter, 3 = PPM w/ E85 meter, 4 = xflow	1 (2 for UHC models)
F17	Dispenser Limits Configuration	.00	Max. # of pulse errors on an in-use pulser (in a transaction), 1-99	10 (50 for UHC models)
		.01	Max. # of pulse errors on an idle/unused pulser, 1-99	80
		.02	Max. # of display errors/filling, 0-99, 0 = disabled	10
		.03	Stop for "no flow" or "flow lost" time limit, 0-1000 secs.	300
		.04	Max. # of consecutive no flow events w/o error, 0-10, 0 = disabled	3
		.05	Max. # of flow lost events w/o error, 0-10, 0 = disabled	3
		.06	Max. # of unfinished fillings, 0-10, 0 = disabled	0
		.07	Max. filling amount/filling, 1-6 digits	9999.00
		.08	Max. volume amount/filling, 1-6 digits	999.000
F18	Blend Ratio Configuration	SN	Blend ratio (data range 0-101) in % of hi feedstock, 101 = disabled for a non-blend	101
F19	Volume Unit Specific Configuration	.10	Suppressed volume @ start of filling, 1-9 cl.	3
		.11	Max. volume for selection of new product, 1-9 cl.	
		.12	Suppress overflow of preset limit, 0-99 cl.	0
		.13	Preset/prepay slow down volume delta, 5-399 cl.	57
		.14	Forward pulse limit on idle/unused WIP, 1-99 cl.	95

Function Number & Name		Sub-function Number & Description		Configuration Setting
		.15	Liters pulse output resolution 0 = Disabled 1 = 1 pulse per unit 2 = 10 pulses per unit 3 = 100 pulses per unit 4 = 250 pulses per unit	3
		.16	Calibration Test Container Volume –Liters (UHC only) 20 – 1000 Liters	20
		.20	Suppressed volume @ start of filling, 1-99 (units of .001 gals.)	9
		.21	Max. volume for selection of new product, 1-99 (units of .001 gals.)	
		.22	Suppress overflow of preset limit, 0-99 (units of .001 gals.)	0
		.23	Preset/prepay slow down volume delta, 2-999 (units of .001 gals.)	150
		.24	Forward pulse limit on idle/unused pulser, 1-999 (units of .001 gals.)	250
		.25	Gallons pulse output resolution 0 = Disabled 1 = 1 pulse per unit 2 = 10 pulses per unit 3 = 100 pulses per unit 4 = 250 pulses per unit 5 = 500 pulses per unit 6 = 1000 pulses per unit	0
		.26	Calibration Test Container Volume – Gallons (UHC only) 5 – 250 Gallons	5
F20	Dispenser Serial Link Configuration	.00	Protocol 1 = RS485 Standard DART 2 = RS485 Full DART 3 = LON 4 = U.S. Current Loop 5 = Reserved 6 = Reserved 7 = CAN Bus Protocol 8 = Reserved 9 = Reserved 10 = LON Standalone 11 = US Legacy DART	4
		.01	Baud rate 1 = 4800 2 = 9600 3 = 19200 4 = 38400	2
		.02	Reserved	2
		.03	Reserved	2
		.04	Reserved	2

Function Number & Name		Sub-function Number & Description		Configuration Setting
F21	Miscellaneous Configuration	.00	Pump motor ON configuration 1 = ON at end of display test 2 = ON at start of display test 3 = ON at product selection	2
		.01	Lock on filling mode configuration 1 = access to filling mode configuration restricted 2 = access allowed	2
		.02	Standalone indication enabled (show four digits right of decimal point) 1 = yes, 2 = no	2
		.03	Blank or dash un-selected unit price displays on product selection 1 = blank, 2 = dash	2
		.04	Product change allowed after fueling started 1 = product change allowed after fueling started 2 = product change not allowed after fueling started	1
		.05	Electro-mechanical totalizer configuration 1 = each side has its own electro-mechanical totalizer 2 = one electro-mechanical totalizer per product shared by both sides	see C.13, C.14 or C.15 by model
		.06	Diagnostic flow rate display 0 = display normal sale amount 1 = display primary product flow rate 2 = display secondary product flow rate 3 = display total flow rate 4 = display Wayne Vac diagnostics	0
F22	Sales Amount Calculation	.00	Denomination ratio between money display and unit price display 1 = 1/1 2 = 10/1 3 = 100/1 4 = 1/10 5 = 1/100 6 = 1/1000	1
		.01	Count by ones or fives in least significant digit of money display 1 = ones 2 = fives	1
		.02	Volume digits to the right of the decimal point used in the amount calculation 0-5, 5 = use volume decimal point as defined in function 14.3	5
		.03	Money preset configuration	0
F23	Miscellaneous Timers	.00	Display test time (test time also known as valve on delay), 2-24 units of ½ sec	6
		.01	Minimum time between fillings, 0-20 units of ½ sec., 0 = disabled	0
		.02	Stop for offline error, 0-30 sec., 0 = disabled	0
		.03	Max. time allowed for filling, 0-60 min., 0 = disabled	0

Function Number & Name		Sub-function Number & Description		Configuration Setting
		.04	Time from unit price change until next start of sale, 0-15 sec.	0
F24	Local Preset Operating Configuration	.00	Preset operation 1 = money only 2 = volume only 3 = default to money 4 = default to volume	3
		.01	Preset entry required before filling 1 = preset required 2 = preset not required	2
		.02	Fill mode display 1 = display "-----" when fill key pressed 2 = display "FILL" when fill key pressed	2
		.03	Preset mode display 1 = display " " on sale display during preset 2 = display "-----" on sales display during preset 3 = display "Preset" on sale display during preset	2
		.04	Preset entry timeout 0-60 seconds, 0=disabled	50
		.05	Preset entry operation 0 = Accumulate preset key entries 1 = Scroll preset key entries	1
		.06	First digit entry point for money 1 through 6, digit 1 is leftmost digit	3
		.07	First digit entry point for volume 1 through 6, digit 1 is leftmost digit	4
		.08	Sale display option 0 = use preset keypad display 1 = use sale display to indicate preset	1

Function Number & Name		Sub-function Number & Description		Configuration Setting
F25	Local Preset SoftKeys Configuration	.01-.32	Represent softkeys which can contain any of the following values 0 = disabled 1 = select softkey value #1 2 = select softkey value #2 3 = select softkey value #3 4 = select softkey value #4 5 = select softkey value #5 6 = select softkey value #6 7 = select softkey value #7 8 = select softkey value #8 9 = select softkey value #9 10 = select softkey value #10 11 = select money 12 = select volume 13 = toggle 14 = select FILL 15 = clear key 16 = enter key	Default
F26	VAP Configuration	.00	ORVR control 1 = enabled 2 = disabled	2
F27	Side A Dispenser Configuration	.00	Button input for local authorize function 0 = Disabled (set for MPI Auth) 8 = Standalone (Requires jumper on display)	8
		.01	MPI Authorization, Side A, logical nozzle 1 0 = Disabled 6 = Switch 6 (normal when enabled) 7 = Switch 7	0
		.02	MPI Authorization, Side A, logical nozzle 2 0 = Disabled 6 = Switch 6 (normal when enabled) 7 = Switch 7	0
F28	Side B Dispenser Configuration	.00	Button input for local authorize function 0 = Disabled (set for MPI Auth) 8 = Standalone (Requires jumper on display)	8
		.01	MPI Authorization, Side B, logical nozzle 1 0 = Disabled 6 = Switch 6 (normal when enabled) 7 = Switch 7	0
		.02	MPI Authorization, Side B, logical nozzle 2 0 = Disabled 6 = Switch 6 (normal when enabled) 7 = Switch 7	0
F29	Side A Liter Flow Rate Configuration	.01	Max. slow flow rate, 3-50 (units of .1 liters/min.) For SHC units, see note in F31.01.	5

Function Number & Name		Sub-function Number & Description		Configuration Setting
		.11	Min. slow flow rate, 0-50 (units of .1 liters/min.), 0 = no minimum	
		.21	Max. fast flow rate, 10-180 (units of liters/min.) For SHC units, see note in F31.01.	38
		.31	Min. fast flow rate, 0-180 (units of liters/min), 0 = no minimum	
F30	Side B Liter Flow Rate Configuration	.01	Max. slow flow rate, 3-50 (units of .1 liters/min.) For SHC units, see note in F31.01.	5
		.11	Min. slow flow rate, 0-50 (units of .1 liters/min.), 0 = no minimum	
		.21	Max. fast flow rate, 10-180 (units of liters/min.) For SHC units, see note in F31.01.	38
		.31	Min. fast flow rate, 0-180 (units of liters/min), 0 = no minimum	
F31	Side A Gallon Flow Rate Configuration	.01	Max. slow flow rate, 1-10 (units of .1 gallons/min.) Note: For SHC units w/ two meters, enter half of the desired total amount.	5
		.21	Max. fast flow rate, 3-48 (units of gallons/min.) For SHC units, see note in F31.01.	10
F32	Side B Gallon Flow Rate Configuration	.01	Max. slow flow rate, 1-10 (units of .1 gallons/min.) For SHC units, see note in F31.01.	5
		.21	Max. fast flow rate, 3-48 (units of gallons/min.) For SHC units, see note in F31.01.	10
F33	Password Change	.00	Service Engineer password, maximum of 6 characters (numeric only)	
		.01	Station Manager password, maximum of 6 characters (numeric only)	
		.02	Station Operator password, maximum of 6 characters (numeric only)	
		.03	Weights & Measures password, maximum of 6 characters (numeric only)	
F34	Diagnostics	.01	Switch test N = nozzle, S = Stop Switch, B = bitbus, P = Preset	
		.02	Display Test	
		.03	Vapor Recovery subsystem test, Side A (Wayne Vac)	
		.04	Vapor Recovery subsystem test, Side B (Wayne Vac)	
F35	Side A Wayne VAC A/L Calibration Data	.00-.01	Wayne Vac calibration	100
F36	Side B Wayne VAC A/L Calibration Data	00-.01	Wayne Vac calibration	100
F37	Satellite Configuration Side A	.01	Simultaneous delivery	1
		.11	Physical nozzle number assignment, 0-8, 0 = None assigned	see C.13, C.14 or C.15 by model
		.21	Product type assignment, 1 = Non-blend, 2 = blend	1

Function Number & Name		Sub-function Number & Description		Configuration Setting
		.31	Primary meter number assignment, 0-8, 0 = None assigned	see C.13, C.14 or C.15 by model
		.41	Secondary meter number assignment, 0-8, 0 = None assigned	see C.13, C.14 or C.15 by model
		.51	Primary valve number assignment 0-8, 0 = None assigned	see C.13, C.14 or C.15 by model
		.61	Primary valve type, 1-2, 1 = on/off, 2 = proportional, 3 = Two stage	2 (3 for UHC models)
		.71	Secondary valve number assignment, 0-8, 0 = None assigned	see C.13, C.14 or C.15 by model
		.81	Secondary valve type, 1-2, 1 = on/off, 2 = proportional, 3 = Two stage	2
		.91	Satellite Indicator (unit price display)	0
F38	Satellite Configuration Side B	.01	Simultaneous delivery	1
		.11	Physical nozzle number assignment, 0-8, 0 = None assigned	see C.13, C.14 or C.15 by model
		.21	Product type assignment, 1 = Non-blend, 2 = blend	1
		.31	Primary meter number assignment, 0-8, 0 = None assigned	see C.13, C.14 or C.15 by model
		.41	Secondary meter number assignment, 0-8, 0 = None assigned	see C.13, C.14 or C.15 by model
		.51	Primary valve number assignment 0-8, 0 = None assigned	see C.13, C.14 or C.15 by model
		.61	Primary valve type, 1-2, 1 = on/off, 2 = proportional, 3 = Two stage	2 (3 for UHC models)
		.71	Secondary valve number assignment, 0-8, 0 = None assigned	see C.13, C.14 or C.15 by model
		.81	Secondary valve type, 1-2, 1 = on/off, 2 = proportional, 3 = Two stage	2
		.91	Satellite Indicator (unit price display)	0
F39	Set Error Severity Level	.xx	xx = selected error number (.25 = price error) 0 = Log Error 1 = Sale Terminated 2 = Semi-Fatal - Affected side of dispenser closed 3 = Fully Fatal - Both sides of dispenser closed 4 = Catastrophic - Both sides closed. Requires power cycle to clear error. 5 = Error detection disabled (price can be zero)	
F41	Pulse Output	.01	Pulse output for nozzles on Side A 0 = Not used 2 = Pulse output for all nozzle on Side A 12 = Pulse output for side A logical nozzle 1	0
		.02	Pulse output for nozzles on Side B 0 = Not used 2 = Pulse output for all nozzle on Side B 12 = Pulse output for side B logical nozzle 1	0

Function Number & Name		Sub-function Number & Description		Configuration Setting
		.03	MPI Reset Complete 0 = Not used 10 = Reset Complete signal for all nozzles on side A 11 = Reset Complete signal for Side A, Logical nozzle 1	0
		.04	MPI Reset Complete 0 = Not used 10 = Reset Complete signal for all nozzles on side B 11 = Reset Complete signal for Side B, Logical nozzle 1	0
		.05	Pulse output for logical nozzle 2 on Side A 0 = Not used 12 = Pulse output for side A logical nozzle 2	0
		.06	Pulse output for logical nozzle2 on Side B 0 = Not used 12 = Pulse output for side B logical nozzle 2	0
		.07	MPI Reset Complete 0 = Not used 11 = Reset Complete signal for Side A, Logical nozzle 2	0
		.08	MPI Reset Complete 0 = Not used 11 = Reset Complete signal for Side B, Logical nozzle 2	0
		.12	MPI Call Signal 0 = Not used 13 = Call signal for Side A, Logical nozzle 1	0
		.13	MPI Call Signal 0 = Not used 13 = Call signal for Side B, Logical nozzle 1	0
		.14	MPI Call Signal 0 = Not used 13 = Call signal for Side A, Logical nozzle 2	0
		.15	MPI Call Signal 0 = Not used 13 = Call signal for Side B, Logical nozzle 2	0
F50	ATC Configuration (Canada Only)	.01	Temperature probe assignment Side A logical nozzle 1 0 = none assigned 1= probe assigned	0
		.05	Temperature probe assignment Side B logical nozzle 1 0 = none assigned 1= probe assigned	0
		.11	Product type assignment Side A logical nozzle 1 0 = Gasoline, 1 = Diesel	0
		.15	Product type assignment Side B logical nozzle 1 0 = Gasoline, 1 = Diesel	0
F95	Upload Dispenser Function Data		Save custom template. Requires laptop and service terminal.	
F96	Upload Flash Memory		Upload code to PC. Requires laptop and service terminal program.	

Function Number & Name		Sub-function Number & Description		Configuration Setting
F97	Upload Configuration		Upload template to PC. Requires laptop and service terminal program.	
F98	Download Flash Memory		Download code to dispenser. Requires laptop and service terminal program.	
F99	Download Configuration		Download template to dispenser. Requires laptop and service terminal program.	

C.13 Configuration Sub-Function Default Settings for Non UHC Models

Sub-function Number & Description		3/G2201/	3/G2202/ 3/G2207/	3/G2203/	3/G2221/ 3/G2227/R	3/G2227/	3/G2227/MR 3/G2228/LM	3/G2227/M
7.01	Dispenser Geometry	1	2	2	1	2	1	2
8.41	Side A 2 nd Meter	0	0	0	5 (2 for ATC units)	2	5 (2 for ATC units)	2
8.71	Side A 2 nd Valve	0	0	0	5	2	5	2
9.41	Side B 2 nd Meter	0	0	0	0	6	0	6
9.71	Side B 2 nd Valve	0	0	0	0	6	0	6
13.01	Side B 1 st Sump	1	1	3	1	1	1	1
21.05	EMT Config.	2	2*	1	2	1	2	1
37.11	Satellite A Nozzle	0	0	0	0	0	4	4
37.31	Satellite A 1st Meter	0	0	0	0	0	1	1
37.41	Satellite A 2nd Meter	0	0	0	0	0	5	2
37.51	Satellite A 1 st Valve	0	0	0	0	0	9	3
37.71	Satellite A 2nd Valve	0	0	0	0	0	10	9
38.11	Satellite B Nozzle	0	0	0	0	0	0	4
38.31	Satellite B 1st Meter	0	0	0	0	0	0	5
38.41	Satellite B 2nd Meter	0	0	0	0	0	0	6
38.51	Satellite B 1 st Valve	0	0	0	0	0	0	7
38.71	Satellite B 2nd Valve	0	0	0	0	0	0	10

*Note: If the Electromechanical Totalizer per Hose option (second suffix K) is included, setting should be "1."

C.14 Configuration Sub-Function Default Settings for UHC Models

(See C.15 for Model 3/G2239/MR)

Sub-function Number & Description		3/G2231/	3/G2237/MR 3/G2238/LM	3/G2232/	3/G2237/M 3/G2236/MR	3/G2233/	3/G2238/M
7.01	Dispenser Geometry	1	1	2	2	2	2
8.41	Side A 2 nd Meter	0	0	0	0	0	0
8.71	Side A 2 nd Valve	0	0	0	0	0	0
9.41	Side B 2 nd Meter	0	0	0	0	0	0
9.71	Side B 2 nd Valve	0	0	0	0	0	0
13.01	Side B 1 st Sump	1	1	1	1	3	3
21.05	EMT Config.	2	2	1	1	1	1
37.11	Satellite A Nozzle	0	4	0	4	0	4
37.31	Satellite A 1st Meter	0	1	0	1	0	1
37.41	Satellite A 2nd Meter	0	0	0	0	0	0
37.51	Satellite A 1 st Valve	0	9	0	9	0	9
37.71	Satellite A 2nd Valve	0	0	0	0	0	0
38.11	Satellite B Nozzle	0	0	0	4	0	4
38.31	Satellite B 1st Meter	0	0	0	5	0	5
38.41	Satellite B 2nd Meter	0	0	0	0	0	0
38.51	Satellite B 1 st Valve	0	0	0	10	0	10
38.71	Satellite B 2nd Valve	0	0	0	0	0	0

C.15 Configuration Sub-Function Default Settings for Model 3/G2239D/MR

- Following is a list of configuration functions and sub-functions that pertain specifically to Model 3/G2239D/MR. Because this Twin II UHC has two hoses on the same side and uses one display, some of the configuration options are different than most units and are shown in this table for the sake of clarity. Product A is Logical Nozzle 1 (Inlet X) and Product B is Logical Nozzle 2 (Inlet Y).

Function Number & Name		Sub-function Number & Description		Configuration Setting
F07	Dispenser Geometry	.01	Dispenser geometry, 1 = single-sided 2 = double-sided	2
F08	Side A Dispenser Type Configuration Part #1	.01	Side A1 - Physical nozzle number assignment, 0-8, 0 = none assigned	1
		.02	Side A2 - Physical nozzle number assignment, 0-8, 0 = none assigned	2
		.11	Side A1 - Product type assignment, 1 = non-blend, 2 = blend	1
		.12	Side A2 - Product type assignment, 1 = non-blend, 2 = blend	1
		.21	Side A1 - Unit price display assignment, 0-8, 0 = none assigned	1
		.22	Side A2 - Unit price display assignment, 0-8, 0 = none assigned	1
		.31	Side A1 - Primary meter number assignment, 0-8, 0 = none assigned	1
		.32	Side A2 - Primary meter number assignment, 0-8, 0 = none assigned	5
		.41	Side A1 - Secondary meter number assignment, 0-8, 0 = none assigned	0
		.42	Side A2 - Secondary meter number assignment, 0-8, 0 = none assigned	0
		.51	Side A1 - Primary valve number assignment, 0-8, 0 = none assigned	1
		.52	Side A2 - Primary valve number assignment, 0-8, 0 = none assigned	5
		.61	Product A1 - Primary valve type, 1-2, 1 = on/off, 2 = proportional, 3 = Two stage	3
		.62	Side A2 - Primary valve type, 1-2, 1 = on/off, 2 = proportional, 3 = Two stage	3
		.71	Side A1 - Secondary valve number assignment, 0-8, 0 = none assigned	0
		.72	Side A2 - Secondary valve number assignment, 0-8, 0 = none assigned	0
F10	Side A Dispenser Type Configuration Part #2	.01	Side A1 - Octane number assignment, 00-99, 00 = non assigned	0
		.02	Side A2 - Octane number assignment, 00-99, 00 = non assigned	0
		.11	Side A1 - Product select button input number assignment, 0-8, 0 = none assigned	0
		.12	Side A2 - Product select button input number assignment, 0-8, 0 = none assigned	0
		.21	Side A1 - Push-to-start button input number assignment, 0-8, 0 = none assigned	0
		.22	Side A2 - Push-to-start button input number assignment, 0-8, 0 = none assigned	0

Function Number & Name		Sub-function Number & Description		Configuration Setting
		.31	Side A1 - Vapor recovery system enabled, 0 = no, 1 = yes	0
		.32	Side A2 - Vapor recovery system enabled, 0 = no, 1 = yes	0
		.41	Side A1 - Beep annunciator in a series of six beeps on physical nozzle lift, 1 = yes, 2 = no	2
		.42	Side A2 - Beep annunciator in a series of six beeps on physical nozzle lift, 1 = yes, 2 = no	2
F12	Side A Pump Assignments	.01	Side A1 - Primary submersible pump relay assignment, 0-8, 0 = none assigned	1
		.02	Side A2 - Primary submersible pump relay assignment, 0-8, 0 = none assigned	1
		.11	Side A1 - Secondary submersible pump relay assignment, 0-8, 0 = none assigned	0
		.12	Side A2 - Secondary submersible pump relay assignment, 0-8, 0 = none assigned	0
F21	Miscellaneous Configuration	.05	Electro-mechanical totalizer configuration 1 =each side has its own electro-mechanical totalizer 2 =one electro-mechanical totalizer per product shared by both sides	2
F29	Side A Liter Flow Rate Configuration	.01	Side A1 - Max. slow flow rate, 3-50 (units of .1 liters/min.)	5
		.02	Side A2 - Max. slow flow rate, 3-50 (units of .1 liters/min.)	5
		.11	Side A1 - Min. slow flow rate, 0-50 (units of .1 liters/min.), 0 = no minimum	
		.12	Side A2 - Min. slow flow rate, 0-50 (units of .1 liters/min.), 0 = no minimum	
		.21	Side A1 - Max. fast flow rate, 10-180 (units of liters/min.)	
		.22	Side A2 - Max. fast flow rate, 10-180 (units of liters/min.)	
		.31	Side A1 - Min. fast flow rate, 0-180 (units of liters/min), 0 = no minimum	
		.32	Side A2 - Min. fast flow rate, 0-180 (units of liters/min), 0 = no minimum	
F31	Side A Gallon Flow Rate Configuration	.01	Side A1 - Max. slow flow rate, 1-10 (units of .1 gallons/min.)	5
		.02	Side A2 - Max. slow flow rate, 1-10 (units of .1 gallons/min.)	5
		.21	Side A1 - Max. fast flow rate, 3-48 (units of gallons/min.)	
		.22	Side A2 - Max. fast flow rate, 3-48 (units of gallons/min.)	
F37	Satellite Configuration Side A	.01	Side A1 - Simultaneous delivery	1
		.02	Side A2 - Simultaneous delivery	1
		.11	Side A1 - Physical nozzle number assignment, 0-8, 0 = None assigned	3
		.12	Side A2 - Physical nozzle number assignment, 0-8, 0 = None assigned	4
		.21	Side A1 - Product type assignment, 1 = Non-blend, 2 = blend	1
		.22	Side A2 - Product type assignment, 1 = Non-blend, 2 = blend	1

Function Number & Name		Sub-function Number & Description	Configuration Setting
		.31 Side A1 - Primary meter number assignment, 0-8, 0 = None assigned	1
		.32 Side A2 - Primary meter number assignment, 0-8, 0 = None assigned	5
		.41 Side A1 - Secondary meter number assignment, 0-8, 0 = None assigned	0
		.42 Side A2 - Secondary meter number assignment, 0-8, 0 = None assigned	0
		.51 Side A1 - Primary valve number assignment 0-8, 0 = None assigned	9
		.52 Side A2 - Primary valve number assignment 0-8, 0 = None assigned	10
		.61 Side A1 - Primary valve type, 1-2, 1 = on/off, 2 = proportional, 3 = Two stage	3
		.62 Side A2 - Primary valve type, 1-2, 1 = on/off, 2 = proportional, 3 = Two stage	3
		.71 Side A1 - Secondary valve number assignment, 0-8, 0 = None assigned	0
		.72 Side A2 - Secondary valve number assignment, 0-8, 0 = None assigned	0
		.81 Side A1 - Secondary valve type, 1-2, 1 = on/off, 2 = proportional, 3 = Two stage	
		.82 Side A2 - Secondary valve type, 1-2, 1 = on/off, 2 = proportional, 3 = Two stage	
		.91 Side A1 - Satellite Indicator (unit price display)	0
		.92 Side A2 - Satellite Indicator (unit price display)	0

Appendix D

Local Authorize / Standalone Operation

D.1 General

- Standalone operation requires a Local Authorization jumper to be plugged into the back of the display board for each hose of the dispenser. See Figure D-1. This provides additional security than allowing the operating mode to just be changed via the infrared remote control. The jumper is factory-installed on all models. If a unit is connected to a fuel control system using the Wayne serial protocol, the jumper should also be removed as an extra security measure.

Figure D-1 Local Authorization Jumper



Local authorization jumper installed in 20-pin connector on back of display board allows dispenser to be placed into standalone operation

D.2 Placing the Dispenser into Standalone Operation

This procedure details how to change the configuration from Serial Mode to Standalone mode.

- Step 1** Turn off the power to the dispenser(s) at the breaker panel.
- Step 2** You will need one Local Authorization jumper for each hose you desire to operate in standalone mode. The jumpers may already be installed in the display boards. If they are, skip to Step 8.
- Step 3** Determine the display panel(s) that need to be opened. The Local Authorization jumper needs to be plugged into the back of the display board for each hose that you desire to operate in standalone mode.
- Island-oriented nozzle models – single or twin:** For island-oriented nozzle models with matching displays on each side of the dispenser, the jumper only needs to be in one of the two matching displays for each hose. Open the display panel that is opposite of the main AC junction box.
- Lane-oriented nozzle models – single or twin:** Lane-oriented models only have one display board per hose, so you will need to open each of the display panels that has a display (singles – one side, twins – both sides).
- Step 4** To open the display panel, support the weight of the display panel with your free hand, and unscrew the two screws on the front bottom edge of the panel. When you have the panel loose, slide it down from underneath the lip of the top panel. Support the panel with your right hand, so the back of the panel is facing up.
- Step 5** Follow the instructions for your model type:
- Island-oriented nozzle models – single or twin:** There should be an empty 20-pin connector on the side of the display board. Carefully push the jumper into the connector (match the tab on the jumper to the notch in the connector). Repeat for both display boards on the panel if it is a twin unit.
- Lane-oriented nozzle models – single or twin:** There should be an empty 20-pin connector on the side of the display board. Carefully push the jumper into the connector (match the tab on the jumper to the notch in the connector). Repeat for both sides of the dispenser if it is a twin unit.
- Step 6** Slide the display panel back underneath the lip of the top panel and re-install the two screws.
- Step 7** Turn on the power to the dispenser at the breaker panel.
- Step 8** Follow the steps in the table below to change the dispenser configuration to standalone operation.

Enter Configuration Mode				
Step	IRC Command	Sale \$ Display	Volume Display	Unit Price Display
1 Service engineer sign on	Press <ENTER>	PASS 1	[blank]	[blank]
2 Enter service engineer password	Type your service engineer password & Press <ENTER>	PASS 2	[blank]	[blank]
3 Enter service engineer password	Type your service engineer password & Press <ENTER>	[software version]	[software date]	F --
Change Authorize Function to Standalone – Side A Nozzle #1 (A1)				
4 Go to Filling Modes dispenser configuration function	Type <1> & Press <ENTER>	-----	[blank]	F 01
5 Go to Filling Modes sub-function	Press <ENTER> again	-----	1 ("1" = set for serial mode)	1.00
6 Clear display	Press <#>	[blank]	[blank]	1.00
7 Enter standalone value	Type <2> for standalone mode & then press <ENTER>	-----	2	1.00
8 Return to function level	Press <ENTER> again	-----	[blank]	F 01
Exit Configuration Mode				
9 Go to exit function	Type <0> and then Press <ENTER>	-----	[blank]	F 00
10 Go to exit sub-function	Press <ENTER> again	-----	1	0.00
11 Clear display	Press "#"	[blank]	1	0.00
12 Exit and save changes	Type <3> and then press <ENTER>	-----	3	0.00
13 Exit configuration	Press <ENTER> again	CHAnGE	StorEd	[price]

Appendix E

Weights & Measures Mode and Temperature Compensation

E.1 Weights & Measures Mode

- Weights & Measures mode provides an audit trail of volume metering unit changes, and if temperature compensation is enabled (Canada), it provides temperature compensation event changes and data. It also provides access to functions F17 (dispenser limits configuration), F19 (volume unit specific configuration), and F22 (sales amount calculation).
- Weights & Measures mode is accessed using the handheld Infrared Remote Control (IRC). To use the IRC, point it at the volume display within a distance of 12 to 18 inches. The Weights & Measures mode is side specific, therefore, it shows the data for the side that you are facing. For twin models with island-oriented nozzles that have two displays on each side, you may need to sign on again into Weights & Measures mode to see values for the meter totals for that side. Since the displays for each “side” of the dispenser show on both the front and back of the dispenser on these models, the software cannot determine the side of the dispenser by just the location of the remote. Reference the Meter Number Assignments table in Section C.11 in Appendix C if you need assistance in determining how meter numbering relates to the hoses.
- Follow the procedures below to access the data.

Volume Metering Unit Event Change Log (To skip directly to Pulse Output Change Log, Press <CLEAR> twice.)				
Step	IRC Command	Sale \$ Display	Volume Display	Unit Price Display
1 View Volume Unit Event Status	Press <CLEAR> Note: If you do not press another button in 20 seconds, the register will change to the Pulse Output log without interaction from the remote.	- [no. of unit change events & meter type]: 01=WIP, 02=PPM board w/ LC, 03=PPM w/ E85, 04=xFLO	- [unit of measure]	Unit
2 View unit change event detail for most recent change event	Press <ENTER> to view Unit Event Change Log	[alternating - meter type - MM.DD.YY]	[alternating - unit of measure - HH.MM]	UC 1
3 View next change event	Press <NEXT> Note: Change event will increment each time you press <NEXT> for the last 10 change events. If you do not press another button in 20 seconds, the register will change to the next event and after completing all events, will move to the Pulse Output log without interaction from the remote.	[alternating - meter type - MM.DD.YY]	[alternating - unit of measure - HH.MM]	UC 2 (up to 10)

- Additional Steps are Continued on the Next Page -

Pulse Output Change Log (To skip directly to ATC status, Press <CLEAR>.)				
IRC Command	IRC Command	Sale \$ Display	Volume Display	Unit Price Display
4 View pulse output event status	Press <CLEAR> Note: If you do not press another button in 20 seconds, the register will change to the ATC log without interaction from the remote.	- [no. of pulse output resolution change events]	- [unit of measure: G=Gallons, L=Liters & pulses per unit: 0=Off or number of PPU]	POut
5 View pulse output change event detail for most recent change event	Press <ENTER> to view Pulse Output Change Log	[alternating - blank - MM.DD.YY]	[alternating - unit of measure: G=Gallons, L- Liters & pulses per unit: 0-Off or number of PPU - HH.MM]	PO 1
6 View next change event	Press <NEXT> Note: Change event will increment each time you press <NEXT> for the last 10 change events. If you do not press another button in 20 seconds, the register will change to the next event and after completing all events, will move to the ATC log without interaction from the remote.	[alternating - blank - MM.DD.YY]	[alternating - Unit of measure: G=Gallons, L- Liters & pulses per Unit: 0-Off or number of PPU - HH.MM]	PO 2 (up to 10)
Automatic Temperature Compensation (ATC) Status (To skip directly to Meter Totals, Press <CLEAR>.)				
7 View ATC Event Status Note: Temp Comp is used in Canada and not in the United States. See "Weights & Measures Mode – Temp Comp Data" section for more detailed information on ATC	Press <CLEAR> Note: If you do not press another button in 20 seconds, the register will change to the Totalizer log without interaction from the remote.	[alternating - no. of ATC change events]	[- ATC status - tC On - tC OFF]	Atc

- Additional Steps are Continued on the Next Page -

Meter Totals (To skip directly to Functions, Press <CLEAR>.)				
IRC Command	IRC Command	Sale \$ Display	Volume Display	Unit Price Display
8 View meter totals (for side you are facing – note that for island-oriented twins with two displays per side, you may need to sign on again to see values for the meter totals for that side)	Press <CLEAR> Note: If you do not press another button in 20 seconds, the register will change to the next totalizer and after completing all totalizers, will move to the Function log without interaction from the remote.	[blank]	[meter 1 total]	tot 1
9 View next meter total	Press <NEXT> Note: Totalizer will increment each time you press <NEXT> for each of the 8 Meters. If you do not press another button in 20 seconds, the register will change to the next totalizer and after completing all totalizers, will move to the Function log without interaction from the remote.	[blank]	[meter 2 -8 totals]	tot 2 (up to 8)
Functions 16, 17, 19, & 22				
10 View function F16	Press <CLEAR> at any time in meter totals or continue to press <Next> until F16 appears	-----	[blank]	F 16
11 View first F16 sub-function “Pulser Configuration”	Press <ENTER> to view sub-function OR Press <NEXT> to go to next Function	-----	[Sub-function value – see “Confuration Functions” for setting info.]	16.00
12 Go to next F16 Sub-function	Press <NEXT> to view sub-functions for F16	-----	[Sub-function value – see “Confuration Functions” for setting info.]	16.01 (16.00 - 16.04)
13 Go to next function – F17	Press <ENTER> to move to next Function	-----		F 17
14 View first F17 sub-function “Dispenser Limits Configuration”	Press <ENTER> to view sub-function OR Press <NEXT> to go to next Function	-----	[Sub-function value – see “Confuration Functions” for setting info.]	17.00
15 Go to next F17 Sub-function	Press <NEXT> to view sub-functions for F17	-----	[Sub-function value – see “Confuration Functions” for setting info.]	17.01 (17.00 – 17.08)

- Additional Steps are Continued on the Next Page -

IRC Command	IRC Command	Sale \$ Display	Volume Display	Unit Price Display
16 Go to next function – F19	Press <ENTER> to move to next function	-----		F 19
17 View first F19 sub-function “Dispenser Limits Configuration”	Press <ENTER> to view sub-function OR Press <NEXT> to go to next function	-----	[Sub-function value – see “Confuration Functions” for setting info.]	19.10
18 Go to next F19 Sub-function	Press <NEXT> to view sub-functions for F19	-----	[Sub-function value – see “Confuration Functions” for setting info.]	19.11 (19.10 - 19.26)
19 Go to next function – F22	Press <ENTER> to move to next function	-----		F 22
20 View first F22 sub-function “Sales Amount Calculation”	Press <ENTER> to view sub-function OR Press <NEXT> to exit W&M mode	-----	[Sub-function value – see “Confuration Functions” for setting info.]	22.00
21 Go to next F22 Sub-function	Press <NEXT> to view sub-functions for F22	-----	[Sub-function value – see “Confuration Functions” for setting info.]	22.01 – 22.03
Exit Weights & Measures Mode				
22 Exit W&M mode	Press <CLEAR> when at function level (F16, F17, etc.)	[last total dollars]	[last transaction volume]	[current price]

E.2 Weights & Measures Mode – Temp Comp Data

- Temperature compensation (Temp Comp) is used in Canada, and is not used in the United States. When temperature compensation is activated, the ATC status (step 7 in Section E.1) will indicate “tC On.”
- To view the Temp Comp Event Log, when you are at the ATC status, follow the steps below.

Temp Comp Event Log				
Step	IRC Command	Sale \$ Display	Volume Display	Unit Price Display
1 View Temp Comp Event Log (10 most recent events)	Press <ENTER> when ATC is on the status display (step 7 in section E.1)	[alternating - blank - MM.DD.YY]	[alternating - ATC status - tC On - tC OFF - HH.MM] Note: If there is not an event, “nonE” will flash	tC 1
2 View next temp comp event	Press <NEXT> Note: Change event will increment each time you press <NEXT>	[alternating - blank - MM.DD.YY]	[alternating - ATC status - tC On - tC OFF - HH.MM] Note: If there is not an event, “nonE” will flash	tC 2
Temp Comp Event Data				
3 View temp comp event data	Press <ENTER>	[- meter no. (1-8) & probe # (0-4)]	[- fuel type (0-gas, 1-diesel)]	tC n (n = whatever event you are on at the time)
4 View next meter’s data for that event	Press <NEXT> Note: Meter will increment each time you press <NEXT>	[- meter no. (1-8) & probe # (0-4)]	[- fuel type (0-gas, 1-diesel)]	tC n
5 View next temp comp event	Press <CLEAR> then <NEXT>	[alternating - blank - MM.DD.YY]	[alternating - ATC status - tC On - tC OFF - HH.MM] Note: If there is not an event, “nonE” will flash	tC “n+1”
Exit Temp Comp Event Logs				
6 Exit temp comp events log & view meter totals	Press <CLEAR>	[blank]	[meter 1 total]	tot 1
Exit Weights & Measures Mode				
7 Exit Weights & Measures Mode	Press <CLEAR> twice	[[last transaction total sale]	[last transaction volume]	[price]

E.3 Temp Comp Fueling Mode

- Temp Comp Fueling Mode is used for verifying the accuracy of the temperature probes used in temperature compensation (Canada). It also changes the volume display to gross volume (uncompensated) which is used when calibrating the meter(s).

Temp Comp Fueling Mode			
Step	Sale \$ Display	Volume Display	Unit Price Display
1 Turn on the temp comp toggle switch located on the horizontal support rail in the hydraulic cabinet.	[compensated volume]	[uncompensated volume] (gross volume)	[probe temperature]
2 Lift nozzle hook handle to turn dispenser on	[during the reset cycle, the following will briefly appear - iGEM software version]	[during the reset cycle, the following will briefly appear in order: - temp comp software version]	[during the reset cycle, when the Temp Comp software version is on the volume display, the status display shows the Volume Correction Factor (VCF) Fuel Type Gas or Diesel]
3 Dispense fuel	[compensated volume]	[uncompensated volume] (gross volume)	[alternating - probe temp. - flow rate]
Exit Temp Comp Fueling Mode			
4 Turn off the temp comp switch in the hydraulic cabinet	[total sale]	[net volume] (compensated)	[price]

- To verify the accuracy of the temperature probes, insert the Weights & Measures probe in the NPT test port on the meter, and then follow the Temp Comp Fueling Mode steps above. Verify the probe temperature shown on the status display with the test probe temperature.

Appendix F

Error Codes

Code	Error	Description	Suggestion
1	Flash program CRC error	Corrupt program area	Bootstrap & Re-Flash program or replace computer base
2	Flash template CRC error	Corrupt or incompatible flash template area	Download correct template, Replace computer base
3-4	Reserved		
5	RAM error log CRC error	Corrupt RAM error log data	Re-Flash program or Replace computer base
6	RAM function programming CRC error	Corrupt RAM function data	Re-Flash program or Replace computer base
7	RAM unit prices CRC error	Corrupt RAM unit price data	Re-Flash program or Replace computer base
8	RAM statistics CRC error	Corrupt RAM statistics data	Re-Flash program or Replace computer base
9	RAM event logs CRC error	Corrupt RAM event log data	Re-Flash program or Replace computer base
10	RAM totals CRC error	Corrupt RAM totals data	Re-Flash program or Replace computer base
11	RAM totalizers CRC error	Corrupt RAM totalizer data	Re-Flash program or Replace computer base
12	RAM Electro-mech totalizers CRC error	Corrupt RAM EMT data	Re-Flash program or Replace computer base
13-15	Reserved		
16	Suppress overflow limit reached – Function 19.12-.22	Slow down limit too low, Defective valve control	Adjust slow down volume- (dispenser or POS), Replace valve
17-20	Reserved		
20	N Consecutive display read back error- Device #: 0=Sales, 1=Unit price, 2=Preset	Defective display board or cable Defective preset board or cable Defective computer base	Replace display board or cable Replace preset board or cable Re-flash program & template or Replace computer base
21-24	Reserved		
25	Sale cannot start-0 Unit price	Unit price not set	Set unit price
26	Sale cannot start-No unit price downloaded	POS has not set a unit price	Set unit price on POS
27	Sale cannot start-Unit price changed-Function 23.04	Unit price has changed prior to start of sale	Check setting function 23.04
28	Sale cannot start-Need preset entry-Function 24.01	Sale requires an entry from preset keypad	Check function 24.01
29	Reserved		
30	No communications with POS timeout-Function 23.02	Communication lost with POS	Verify data-link connection & polarity to POS
31-32	Reserved		
33	Sale aborted because Stop button was pushed	Stop button pushed or stop button defective	Verify stop button functionality
34	Reserved		

Code	Error	Description	Suggestion
35	Blend ratio out of tolerance- Function 7.02	Inlet pressures too low, too high Product flow restriction	Check inlet pressures Check product flow paths- (filters, strainers, valves...)
36-38	Reserved		
39	Pulse Output lags by more than 1 second	Pulse output unable to keep up with fuel flowrate	Reduce pulse output resolution settings F19.15/F19.25
40-41	Reserved		
42	Vapor recovery motor on when it should be off	Cables plugged into wrong position on Wayne Vac control board Wrong dispenser template installed Defective Wayne Vac control board Defective computer board Defective Wayne Vac motor	Reconnect cables to control board per wiring diagram Re-Flash program & template Replace Wayne Vac control bd Replace computer & Re-flash program & template Replace motor
43	Vapor recovery motor on when it should be on	Cables plugged into wrong position on Wayne Vac control board Wrong dispenser template installed Defective Wayne Vac control board Defective computer board Defective Wayne Vac motor	Reconnect cables to control board per wiring diagram Re-Flash program & template Replace Wayne Vac control bd Replace computer & Re-flash program & template Replace motor
44-45	Reserved		
46	Vapor recovery motor turning wrong direction	Defective Wayne Vac motor or cables Defective Wayne Vac board	Replace Replace
47	Illegal sensor states from vapor recovery system	Defective Wayne Vac motor or cables Defective Wayne Vac board	Replace Replace
48	Vapor recovery motor load high	Defective Wayne vac motor Blocked vapor path	Replace Wayne vac motor Check vapor return path (nozzle, hose)
49	Vapor recovery motor load low	Defective Wayne vac motor	Replace Wayne vac motor
50	Jitter/Reverse limit reached on an In Transaction WIP	Defective WIP	Replace
51	Jitter limit reached on an idle WIP	Defective WIP Product crossflow	Replace Check for product crossflow
52-53	Reserved		
54	Reverse flow limit reached on idle WIP	Defective check valve	Replace valve
55	Reserved		
56	Forward flow limit reached on an idle WIP	Defective flow control valve	Replace valve
57	Reserved		
58	Communication lost to an In Transaction WIP	Defective WIP Defective ISB or cables	Replace WIP Replace ISB or cables
59	Communication lost to an idle WIP	Defective WIP Defective ISB or cables	Replace WIP Replace ISB or cables
60-61	Reserved		
62	WIP is outputting jitter	Calibration volume exceeded limit Defective WIP	Too much fuel dispensed during a meter calibration Replace WIP
63-66	Reserved		

Code	Error	Description	Suggestion
67	WIP calibration OK bit status changed	WIP has been calibrated	
68	WIP calibration door status changed	WIP door was opened/closed	
69	WIP last calibration status changed	WIP has been calibrated	
70	Timeout limit reached for No Flow Function 17.02 (flow never started)	Defective flow control valve or cables Defective pump/motor control relay Defective nozzle	Replace valve or cables Replace pump/motor control relay Replace nozzle
71	n Consecutive No Flow Timeouts – Function 17.03	Defective flow control valve or cables Defective pump/motor control relay Defective nozzle Defective iGEM computer	Replace valve or cables Replace pump/motor control relay Replace nozzle Replace iGEM computer
72	Timeout limit reached for No-Flow – Function 17.02 (Flow Lost during sale)	Defective flow control valve or cables Defective pump/motor control relay Defective nozzle Defective iGEM computer	Replace valve or cables Replace pump/motor control relay Replace nozzle Replace iGEM computer
73	n Consecutive Flow Lost Timeouts – Function 17.04	Defective flow control valve or cables Defective pump/motor control relay Defective nozzle Defective iGEM computer	Replace valve or cables Replace pump/motor control relay Replace nozzle Replace iGEM computer
74	Sale terminated before Preset Limit reached – Unfinished fueling	Defective flow control valve or cables Defective pump/motor control relay Defective nozzle Defective iGEM computer	Replace valve or cables Replace pump/motor control relay Replace nozzle Replace iGEM computer
75	N Consecutive unfinished fillings	Defective flow control valve or cables Defective pump/motor control relay Defective nozzle Defective iGEM computer	Replace valve or cables Replace pump/motor control relay Replace nozzle Replace iGEM computer
76-79	Reserved		
80	Mail buffer memory pool exhausted – Internal error	Defective iGEM board	Replace iGEM board
81-89	Reserved		
90	Fuel temperature board communication failure	Defective FTB Defective FTB cable Defective iGEM computer	Replace FTB Replace FTB cable Replace iGEM computer
91	Fuel temperature board temperature probe shorted	Defective temperature probe Defective FTB	Replace temperature probe Replace FTB
92	Fuel temperature board temperature probe open	Defective temperature probe Defective FTB	Replace temperature probe Replace FTB
93	Reserved		
94	ATC configuration error	ATC function data programmed incorrectly	Verify/Correct ATC programming function F50
95-98	Reserved		
99	Hardware/Software mismatch – Device #: 0=No proportional hardware, 1=No VR hardware	Defective Wayne vac board or cables Defective iGEM computer	Replace Wayne vac board or cable Replace iGEM computer

Appendix G

Internal Wiring & Connections

G.1 Internal Wiring – CPU (Non UHC Models)

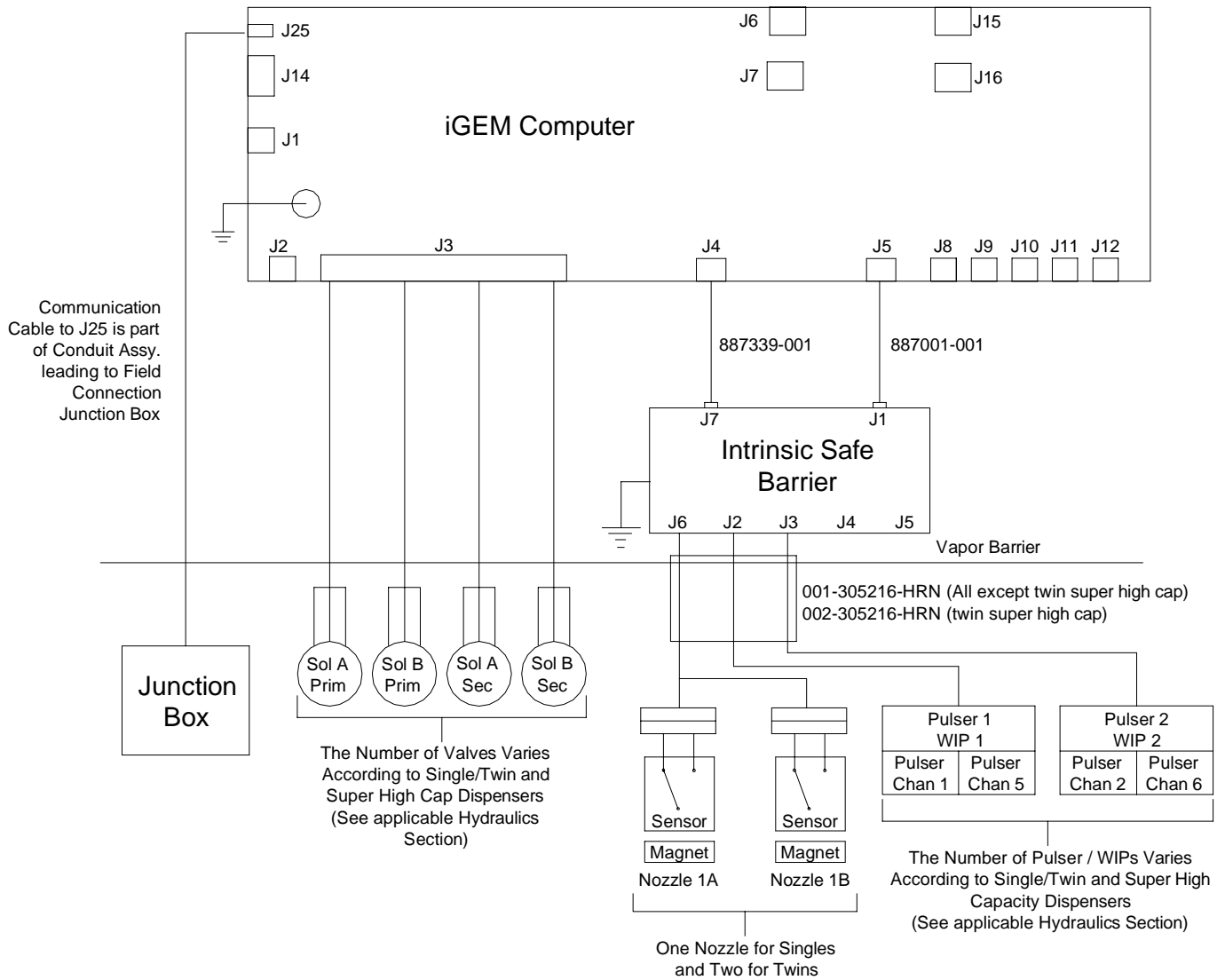

G.2 Internal Wiring – CPU (UHC Models)\

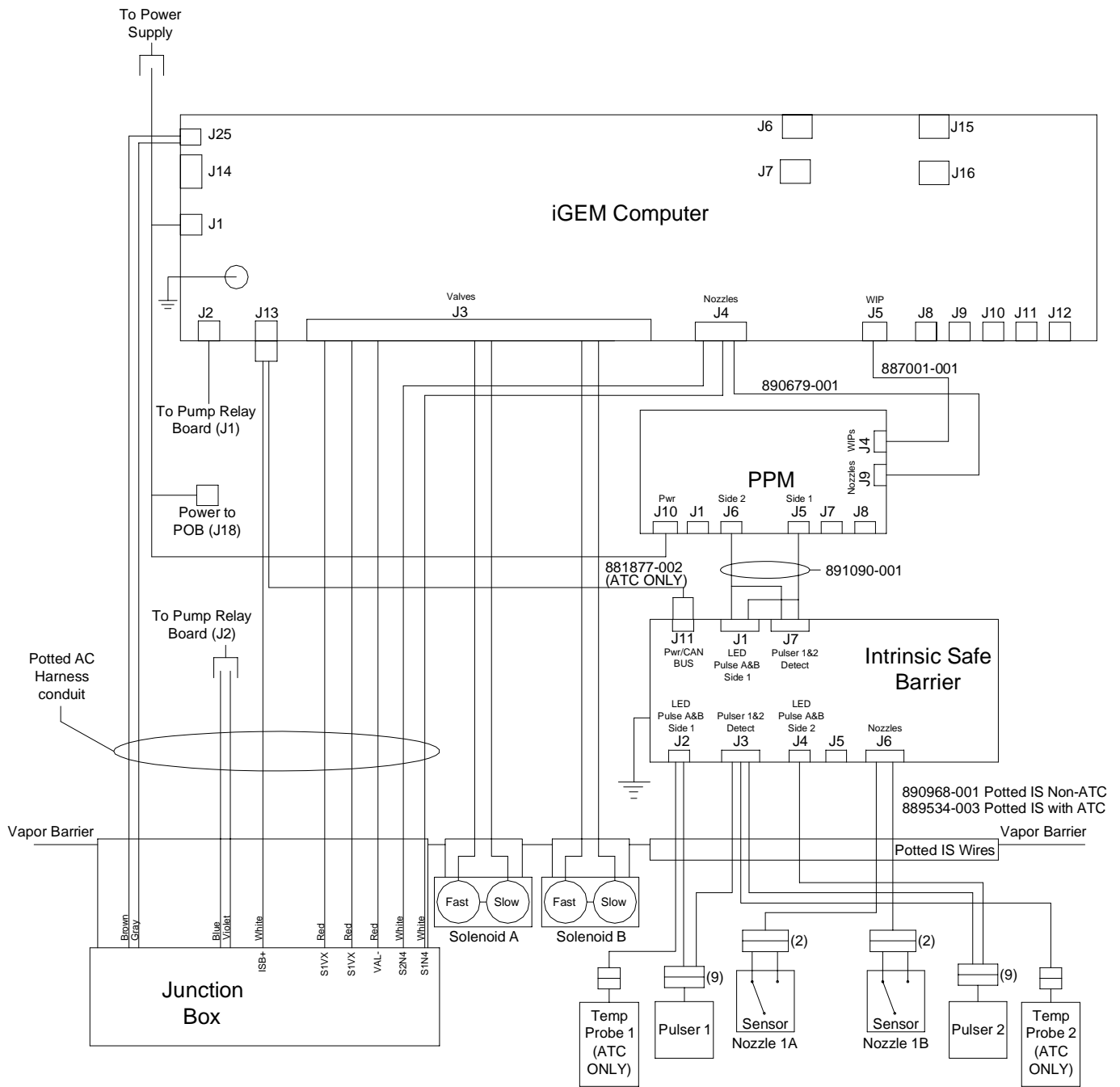

G.3 Internal Wiring – Displays

Island-Oriented

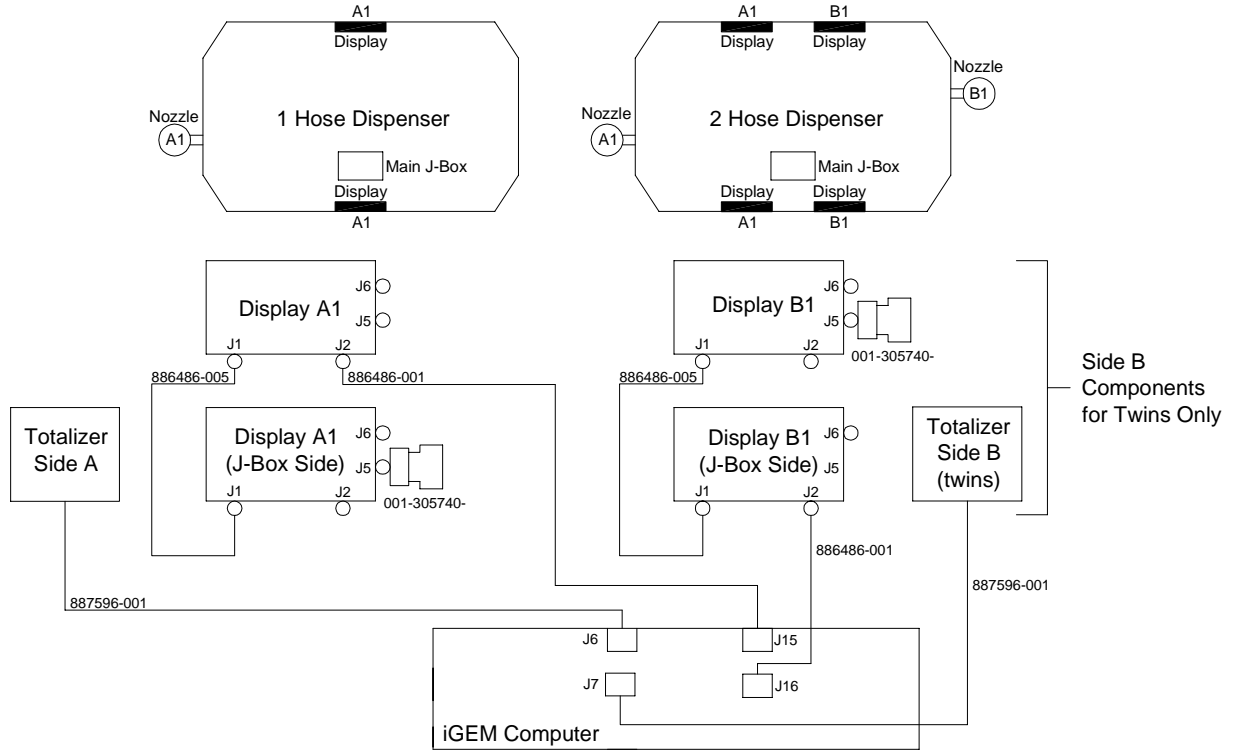

Lane-Oriented

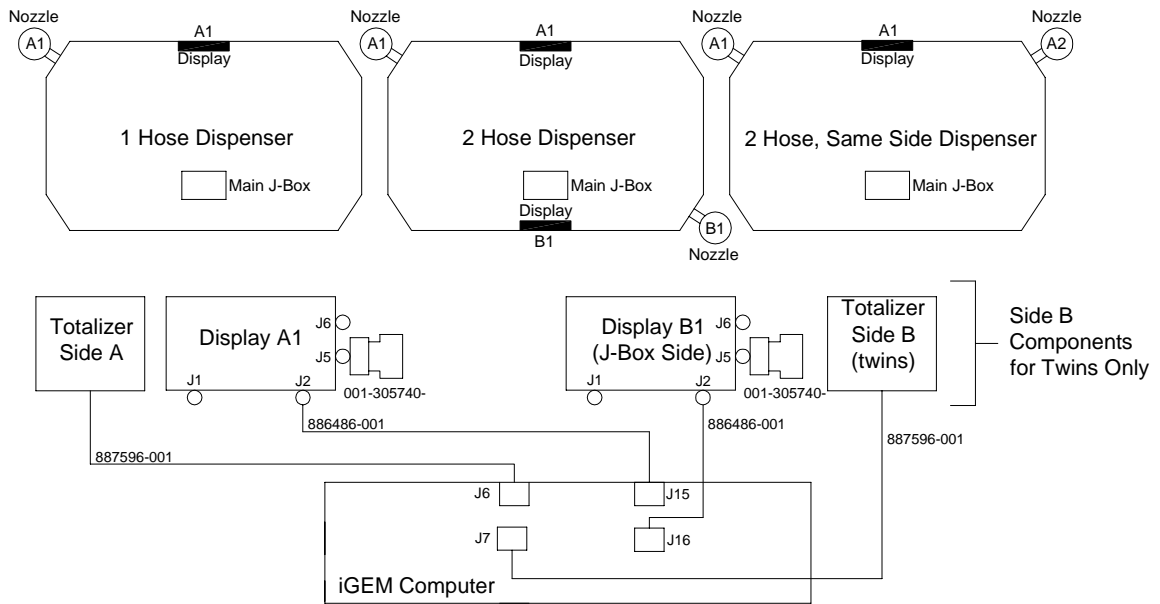

G.4 Internal Wiring – Power for Remote Dispensers

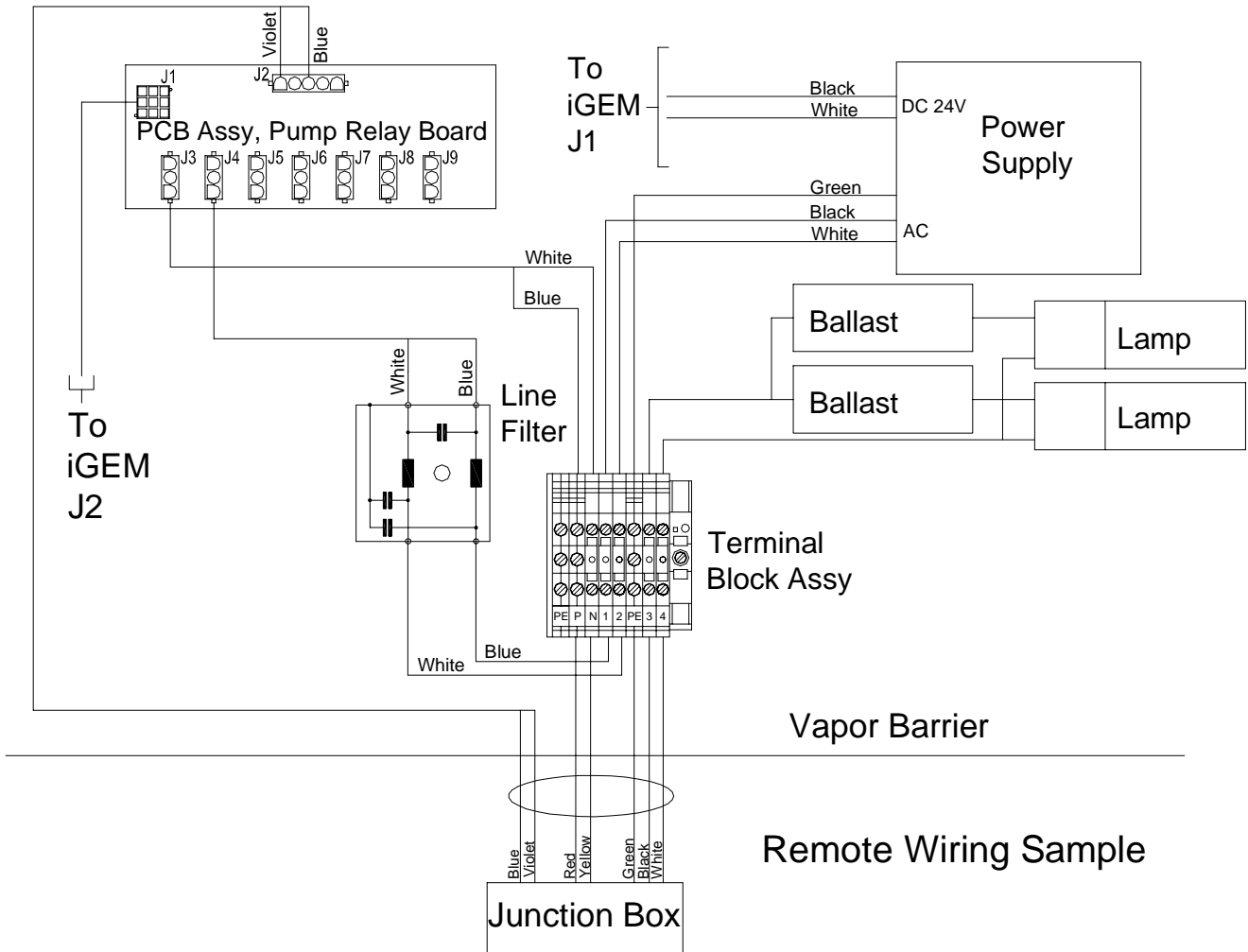

G.5 Internal Wiring – Power for Suction Pumps

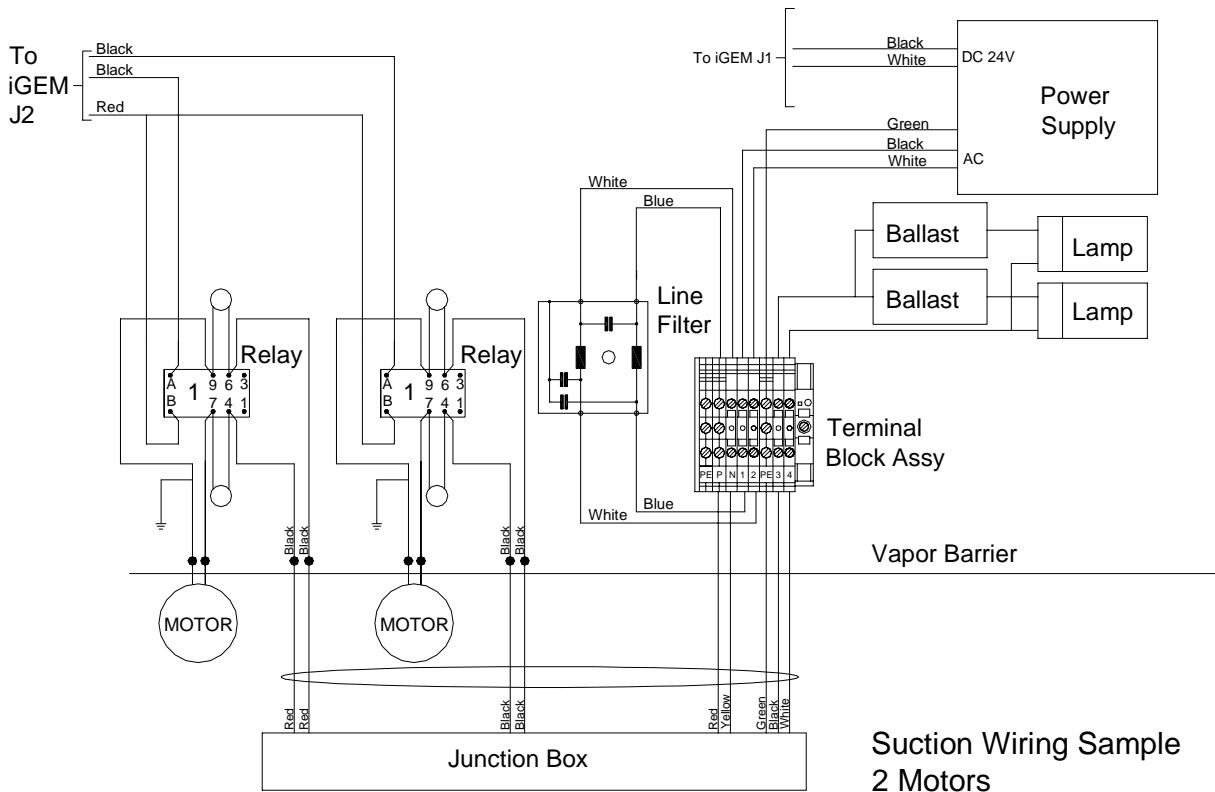
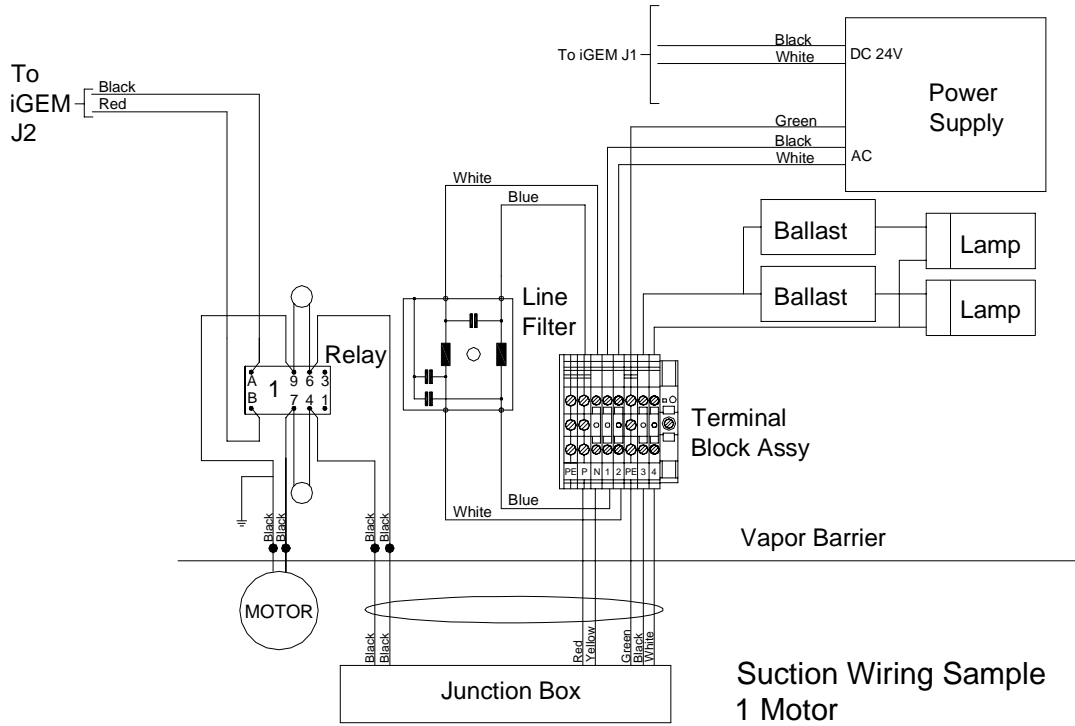

G.6 Internal Wiring – Connectors

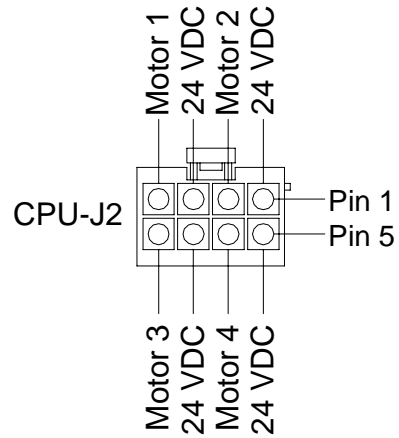
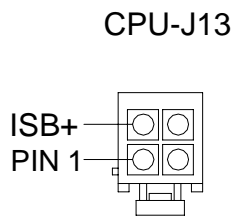
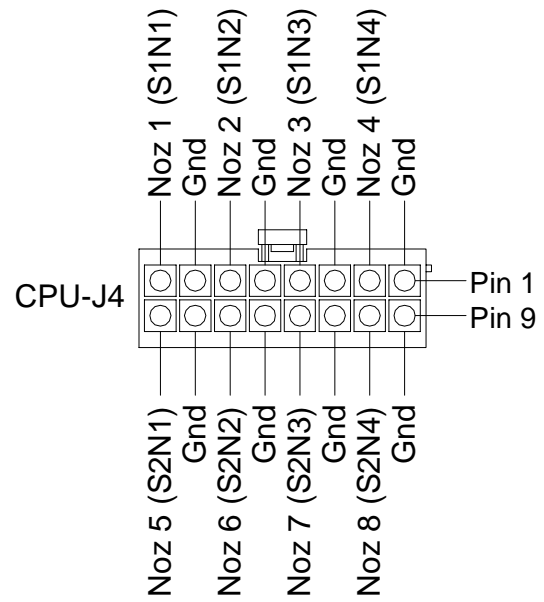
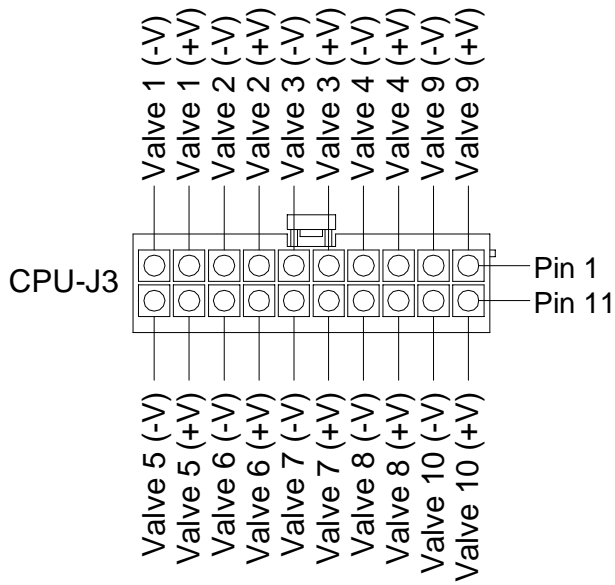

RELAY-J2

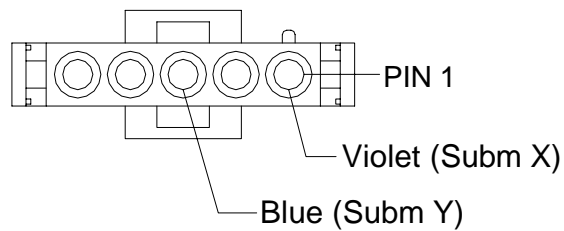

INSTALLATION & OPERATION MANUAL

Century Series Dispensers

Copyright ©2006 Dresser, Inc.
All rights reserved.
Printed in the United States of America.

The information in this publication is proprietary and confidential. No part of this publication may be electronically or mechanically reproduced, stored in a retrieval system, or transmitted, in any form or means, without express written permission by Dresser, Inc. Translation of this material to another language without express written permission by Dresser, Inc. is prohibited.

The information in this publication is for informational use only and is subject to change without notice. The contents should not be construed as a commitment by Dresser, Inc. who assumes no responsibility or liability for inaccuracies that may appear in this publication.

**Dresser Wayne, Dresser, Inc., is located at 3814 Jarrett Way, Austin TX 78728.
Wayne's general telephone number is (512) 388-8311.**



Wayne

Wayne Division, Dresser, Inc.
Part No. 921278 Rev F

3814 Jarrett Way, Austin, TX 78728
©2006 Dresser, Inc.

(512) 388-8311
March/06