

100 SERIES HIGH PRESSURE HOUSING

An economical, compact housing that can be adapted to serve as either a filter, liquid filter separator or air/gas entrainment separator depending upon the cartridge(s) selected to meet the application requirements. It is designed for use on liquids, fuels, compressed air or natural gas streams to remove solids only (*filter*), or to remove water and particulate matter from fuels, oils and other immiscible fluids (*liquid filter separator*), or to remove entrained hydrocarbons, water mist and solids from compressed air or natural gas streams (*air/gas entrainment separator*).

For solids removal only from compressed air, natural gas or liquids, the nominal micron rating of the filter cartridge is important in determining which cartridge should be used in the filter housing to meet the application requirements.

To remove water and particulate matter from fuels, oils and other immiscible fluids or to remove entrained hydrocarbons, water mist and solids from compressed air or natural gas streams, the type of media and micron rating are important in selecting the right cartridges to install in the liquid filter separator or air/gas entrainment separator housing to achieve the required performance.

STANDARD HOUSING DESIGN FEATURES

- Body: Carbon steel - welded construction to best commercial practice
- Interior: Epoxy coated
- Exterior: Shop primer
- Closure: Victaulic
- Closure seal: Buna-N o-ring—other materials available on request
- Center pipe: Cadmium plated carbon steel
- Internal seals: Die cast aluminum
- Inlet and outlet connections: 1" 3000# NPT coupling
- Vent and drain connections: 1/4" NPT and 3/4" NPT respectively
- Maximum operating temperature of 180°F is recommended for all air/gas
- Maximum pressure rating of 1000 psi

FLOW DIAGRAMS

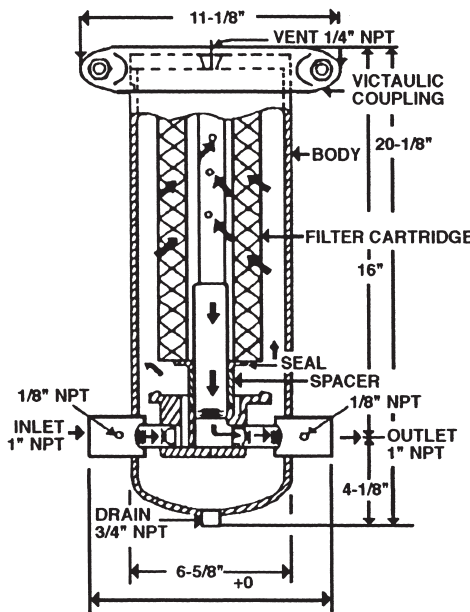

Filter

To remove solids only from liquid, compressed air or natural gas streams. The flow diagram above shows the product entering the inlet and traveling up and through the filter cartridge. The clean, filtered product then flows down through the center tube and out the outlet.

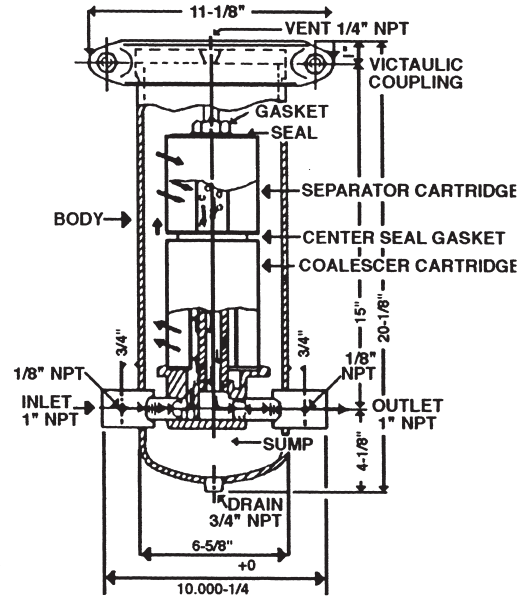

Liquid Filter Separator or Air/Gas Entrainment Separator

To remove water and solids 2 micron and larger from fuels, oils, and other immiscible fluids, or to remove entrained liquids and solids 0.5 microns and larger from compressed air or natural gas streams. The flow diagram above shows how the product is cleaned in one pass through the first stage coalescer cartridge center core. The clean product then travels up to the second stage separator cartridge. Any small water droplets not forced to settle by gravity are repelled with only the clean product passing through the separator cartridge, entering the center tube and flowing down and out the outlet.

FLOW RATES

AIR/GAS ENTRAINMENT SEPARATOR 3AGB-S-1D6-1404-100

OPERATING PRESSURE		FLOW	
psi	kg/cm ²	scfm	cm/h
10	.70	75	127.2
25	1.76	95	161.4
40	2.80	105	178.2
50	3.50	120	204.0
75	5.25	135	229.2
100	7.00	155	263.4
150	10.50	180	306.0
200	14.06	215	365.4
250	17.57	240	408.0
300	21.09	260	441.6
350	24.60	285	484.2
400	28.12	300	510.0
500	35.15	360	612.0
600	42.18	380	645.6
700	49.21	405	688.2
800	56.24	430	730.8
900	63.27	460	781.8
1000	70.30	485	824.4

Initial Pressure Drop 2 PSI (14 kg/cm²)

LIQUID FILTER SEPARATOR VCS-1DG-1B3-100

FUEL	INITIAL ΔP		FLOW	
	psi	kg/cm ²	gpm	lpm
Diesel	2.4	.169	7	26.5
Kerosene	5.0	.352	12	45.4

FILTER

MODEL	32 SSU		46 SSU		58 SSU		98 SSU		140 SSU		190 SSU		230 SSU	
	2 CS		6 CS		10 CS		20 CS		30 CS		40 CS		50 CS	
	gpm	lpm	gpm	lpm	gpm	lpm	gpm	lpm	gpm	lpm	gpm	lpm	gpm	lpm
1A1-S-LP2-1-100	8.2	31.0	2.8	10.6	1.6	6.1	0.8	3.0	0.6	2.3	0.4	1.5	—	—
1A1-S-LP10-1-100	20.0	75.7	20.0	75.7	15.0	56.8	7.5	28.4	5.0	18.9	3.8	14.4	3.0	11.4
1A1-S-LP25-1-100	20.0	75.7	20.0	75.7	20.0	75.7	20.0	75.7	20.0	75.7	20.0	75.7	20.0	75.7

DATA - FILTER

MODEL NUMBER	OVERALL LENGTH		SHIPPING WEIGHT		FILTER CARTRIDGES	MICRON		REMARKS
	in.	mm.	lbs.	kgs.		Liquid	Air/Gas	
1A1-S-LP2-100	20 $\frac{1}{8}$	511	56	25	(1) LP2	2	0.5	Removes solids only from liquids, compressed air or natural gas streams.
1A1-S-LP10-100	20 $\frac{1}{8}$	511	56	25	(1) LP10	10	2	
1A1-S-LP25-100	20 $\frac{1}{8}$	511	56	25	(1) LP25	25	10	

The above filter cartridges are 4 $\frac{1}{8}$ " (105 mm) OD and 9 $\frac{1}{4}$ " (235 mm) long.

DATA - LIQUID FILTER SEPARATOR

MODEL NUMBER	OVERALL LENGTH		SHIPPING WEIGHT		CARTRIDGES		MICRON		REMARKS
	in.	mm.	lbs.	kgs.	Separator	Coalescer	Liquid	Air/Gas	
VCS-1D6-1B3-100	20 $\frac{1}{8}$	511	56	25	(1) SB3	(1) CD6V	2	0.5	Two-stage removal of water and solids.

Separator cartridges are 4 $\frac{1}{8}$ " (105 mm) OD and 3 $\frac{7}{8}$ " (98 mm) long.
 Coalescer cartridges are 4 $\frac{1}{8}$ " (105 mm) OD and 6 $\frac{5}{8}$ " (168 mm) long.

DATA - AIR/GAS ENTRAINMENT SEPARATOR

MODEL NUMBER	OVERALL LENGTH		SHIPPING WEIGHT		CARTRIDGES		MICRON		REMARKS
	in.	mm.	lbs.	kgs.	Separator	Coalescer	Liquid	Air/Gas	
3AGB-S-1D6-1404-100	20 $\frac{1}{8}$	511	56	25	(1) SP404NCV-1	(1) CD6V	2	0.5	Removes hydrocarbon and/or water mist and solids.

The separator cartridge is 4 $\frac{1}{8}$ " (105 mm) OD and 3 $\frac{7}{8}$ " (98 mm) long.
 The coalescer cartridge is 4 $\frac{1}{8}$ " (105 mm) OD and 6 $\frac{5}{8}$ " (168 mm) long.

NOTES:

Cartridges withstand differential pressure of 75 psi (5.25 kg/cm²) without structural failure.
 Structural components are carbon steel protected with a corrosive resistant coating.
 Standard gaskets and o-rings are Buna-N. Other materials available on request.
 All dimensions and weights are approximate.