

The Most Trusted name in Pumps & Meters

**FILL-RITE.**

## Series 300 & 700 AST Pumps



Model 713



Model 303/313

**FILL-RITE**

## Description of Included Models

Model Number	Description
FR713	<b>Series 700B (15-18 GPM) Utility Pump</b> 1/3 HP 110 VAC - 60 Hz Motor. "Economy" pumping unit for use with AST remote dispensers configured with anti-siphon device, tank adapter, fittings and pipe from anti-siphon device to tank adapter. NO NOZZLE, HOSE OR NOZZLE BOOT INCLUDED.
303	<b>Series 300 (20 GPM) 1/2 hp Utility Pump for Gasoline.</b> "Economy" pumping unit for use with AST remote dispensers configured with anti-siphon device, tank adapter, fittings and pipe from anti-siphon device to tank adapter, 1/2 HP - 110/220 VAC 50/60 Hz motor. NO NOZZLE, HOSE OR NOZZLE BOOT INCLUDED.
313	<b>Series 300 (30 GPM) 3/4 hp Utility Pump for Diesel.</b> "Economy" pumping unit for use with AST remote dispensers configured with anti-siphon device, tank adapter, fittings and pipe from anti-siphon device to tank adapter, 3/4 HP - 110/220 VAC 50/60 Hz motor. NO NOZZLE, HOSE OR NOZZLE BOOT INCLUDED.

## Safety Listings

Approval Mark	Organization Description	File Number	Guide Number
	<b>Underwriters Laboratories Inc.</b> , a nationally recognized independent organization for testing of products to ensure public safety. Recognized and accepted in USA, Canada and other countries	<b>MH5329</b>	<b>EWTV</b>

## Available Options

Option	Description	Shipping Weight (lbs.)	Shipping Weight (kgs.)
E	Unit supplied with 220 VAC - 50 Hz motor	-	-

## Accessories

Part Number	Description
<b>F1088</b>	Anti-siphon kit for the Model FR713
<b>F1089</b>	Anti-siphon kit for the Models 303 and 313
<b>F3144</b>	Automatic nozzle (unleaded) 3/4"
<b>F3529</b>	Switch lock retrofit kit
<b>F7767</b>	Manual nozzle (Hi-Flow) 1"
<b>F7773</b>	Hose 1" X 12' with ferrules.
<b>F7801</b>	Automatic nozzle (unleaded) 1".

## Performance

Characteristic	FR713	303	313
<b>Maximum Outlet Pressure</b>	20 PSI (1.52 BAR)	25 PSI (1.73 BAR)	25 PSI (1.73 BAR)
<b>Maximum Flow Rate (1)</b>	18 GPM (68 LPM)	20 GPM (75.8 LPM)	30 GPM (114 LPM)
<b>Maximum Viscosity of fluid pumped</b>	Diesel Fuel	Diesel Fuel	Diesel Fuel
<b>Maximum ambient operating temperature</b>	150 °F (66 °C)*	150 °F (66 °C)*	150 °F (66 °C)*
<b>Minimum ambient operating temperature</b>	-15 °F (-26 °C)*	-15 °F (-26 °C)*	-15 °F (-26 °C)*
<b>Minimum dry vacuum</b>	14 Inches of mercury	14 Inches of mercury	14 Inches of mercury
<b>Minimum suction lift**</b>	15 feet for diesel. For gasoline see below.***	18 feet for diesel. For gasoline see below.***	18 feet for diesel. For gasoline see below.***

1 Nominal flow rate at nominal voltage using a standard hose and manual nozzle with low viscosity fluid.

\* Consult factory for extreme temperature applications outside this range.

\*\* The lift in feet is equivalent to the vertical distance from the surface of the fluid in the tank to the inlet of the pump, PLUS the friction losses through the vertical and horizontal runs of pipe, all elbows and other fittings.

The system should be designed to require a minimum amount of suction lift.

\*\*\* Lift of gasoline dependent on Reid's vapor pressure of the gasoline and it's temperature. The lower the vapor pressure and temperature, the higher the possible lift. Review Practical Gasoline Suction Lift Considerations to determine the lift for gasoline you might expect.

## Flow Curve

- A. FR713 with 12' of 3/4" hose and manual nozzle.
- B. FR713 with 12' of 3/4" hose and automatic nozzle.
- C. FR713 with 12' of 3/4" hose and manual nozzle and FR305R dispenser.

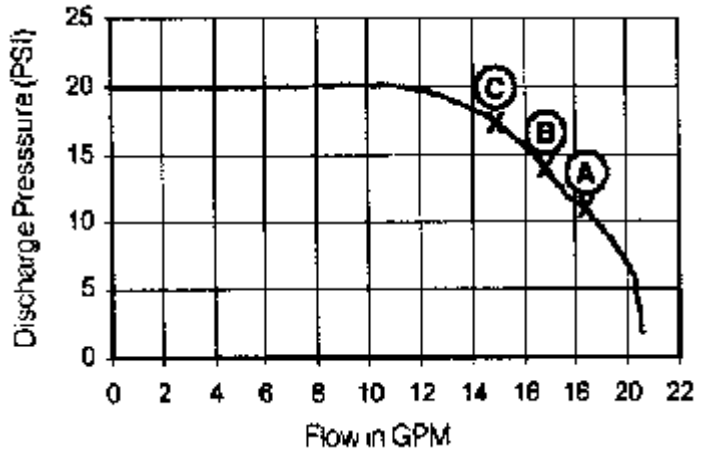

Nominal flow curve for reference only. Based on 3 feet suction lift. Actual flow rates obtained may vary.

- 1. 313 with 12' of 3/4" hose and manual nozzle.
- 2. 313 with 12' of 3/4" hose and automatic nozzle.
- 3. 313 with 12' of 3/4" hose and manual nozzle and FR305R dispenser.

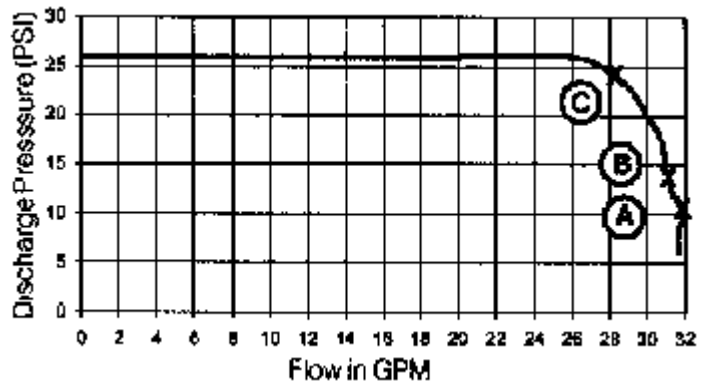

Nominal flow curve for reference only. Based on 3 feet suction lift. Actual flow rates obtained may vary.

## Fluid Compatibility

The FR713, 303 and 313 pumps are compatible with the following fluids:

Diesel, Gasoline, Kerosene, Mineral Spirits, Heptane and Hexane.

**Note: Only the 303 and FR713 versions are recommended for gasoline applications.**

The FR713, 303 and 313 pumps are NOT compatible with the following fluids:

Acetone, Ammonia, Benzene, Bleach, Hydrochloric Acid, Water, Ink and Toluene.

If in doubt about the compatibility of a specific fluid, contact the supplier of the fluid to check for any adverse reactions to the following wetted materials:

Cast Iron  
Bronze/Iron  
Fiber  
Zinc Plated Steel

Steel  
Carbon  
Fluorocarbon (Viton®)  
Ceramic

Stainless Steel  
Polyester  
Buna N  
Aluminum

## Dimensions

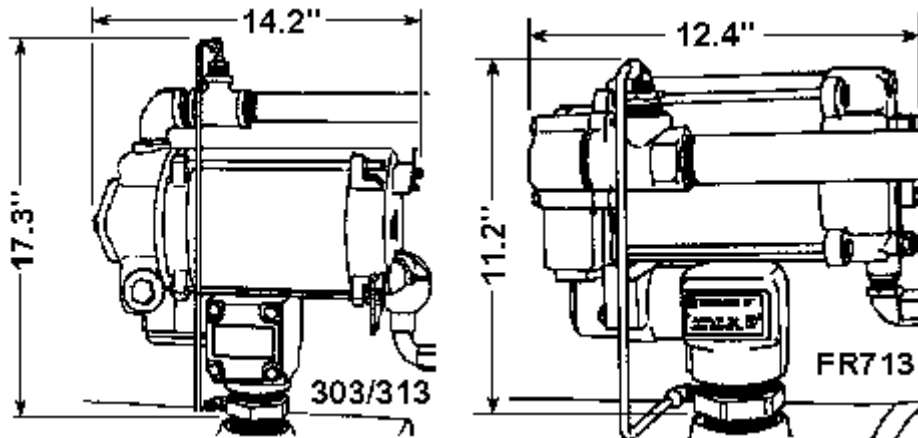

## Repair

To insure the ultimate performance, pumps must be set up according to the "INSTALLATION" section of the Owner's Manual packed with the pump and available below in the **eLibrary** section.

To maintain UL Listing of this Explosion Proof pump, motor service can only be performed by a Recognized Service Center. The pump must be thoroughly flushed and drained before packing for shipment, or taken in for service.

## Maintenance

To keep the pump running at its best, periodically perform the following procedures:

1. Check strainer for dirt accumulation. To clean strainer, remove pump strainer cover and pull out screen.
2. Remove rotor cover and inspect motor vanes. Vanes should be replaced after extensive wear to prevent damage to pump. If more than 1/2 the total blade length extends out of the rotor slot at the extreme of travel, the wear is excessive.
3. Check hose and nozzle for wear or damage. Bad hoses or nozzles are potential safety hazards.

## Frequently Asked Questions

### 1. My pump only pumps for a few minutes and then stops. What is happening?

Generally "short cycling" indicates the motor is drawing too much current from the power source for some reason, and the thermal relay is opening to protect the insulation from the resulting heat build up. If this is what

is happening the thermal relay will reset after 10 to 20 minutes and the motor will again operate. The causes of too high a current are many. The pump is designed for low viscosity fluid, like diesel or gasoline, and will overheat if used to pump oil or other higher viscosity fluids. The inlet filter screen could be clogged. Motor bearings could be defective resulting in a drag on the motor shaft rotation.

See the Troubleshooting Guide in your Owner's Manual packed with your unit or the copy available "on-line" in the Reference Documents section of this More Info page for things to check.

## **2. There is fluid leaking out of the small hole in the bottom of the pump body. How do I stop it?**

This small hole is described as the "weep hole" and is positioned to drain fluid that has leaked passed the dynamic seal between the pump and the motor. It is important that the leak be corrected as soon as possible to avoid damage to the front motor bearing. The problem could be as simple as foreign materials preventing the ceramic and carbon seal components from being in intimate contact, to as complex as a defective casting.

See the Troubleshooting Guide in your Owner's Manual packed with your unit or the copy available "on-line" in the Reference Documents section of this More Info page for things to check.

## **3. What can I do to avoid my pump losing prime when it sets for a time?**

Maintaining "prime" or keeping fluid in the inlet piping of your pumping system requires that no air leak into that piping. Generally you can depend on there being a check valve in your pump preventing air from entering your system through the nozzle, should it be opened while the pump is off. If your pump is consistently losing prime, remove and inspect the check valve to insure it is sealing properly. Also check all inlet piping joints and fittings and the various covers and plugs in the pump itself. Teflon® type sealing tape or a sealing compound noted as resistant to fuels is recommended at all threaded piping connections.

## **4. When it gets hot outside my pump will not pump gasoline but my diesel pump works great, what is going on?**

A suction pump works by developing a vacuum above the fluid being pumped and depending on atmospheric pressure to force that fluid into that vacuum. The higher the fluid is being raised, the more vacuum is required. If the fluid turns to a gas at a lower vacuum than that required to raise the fluid out of the container, the system is said to be vapor locked. In other words, rather than enough vacuum being developed by the pump to raise the fluid, the pump is instead vaporizing the gasoline and only gas vapor is being pumped. Diesel has a very low vapor pressure at even relatively high temperatures so there is no danger of vapor locking at practical temperatures. Gasoline is blended to have different vapor pressures to aid winter starting (high vapor pressure) or avoid vapor locking in the summer (lower vapor pressure). The unit of measure used in the industry for this characteristic is Reid's Vapor Pressure. Having winter gas (high Reid's Vapor Pressure), still available in your tank in a hot spring, is a common cause of vapor locking pumps.

Once the situation exists, there are a limited number of options. Decrease the "lift" needed to raise the gasoline by filling the tank to the top is the easiest and quickest. This has the added benefit of mixing in a hopefully new blend of gasoline with a lower vapor pressure which will average the blended Reid's Vapor Pressure down. Another option is to decrease the temperature by shading and/or cooling the piping and pump in some fashion.

In new systems make sure the suction pump is installed at the lowest position possible, as that decreases the lift, and always install the pump and piping out of the hot sun if at all possible. Know what the Reid's Vapor pressure is of the gasoline you buy. Your supplier has, or can get, that characteristic of the gasoline for you. The Reid's vapor pressure should be 9 to 8, or lower, in the summer and 11 to 12 in the winter.